

CP 225-1
September

RESEARCH REPORTS

Sheep and Goat, Wool and Mohair--1966

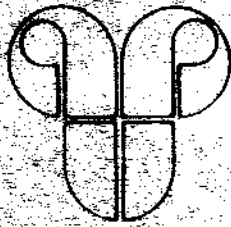

The Texas Agricultural Experiment Station
Neville P. Clarke, Director, College Station Texas
The Texas A&M University System

Foreword

For many years, research conducted for the sheep and goat industry by scientists of the Texas Agricultural Experiment Station has been summarized in a TAES Consolidated Progress Report for dissemination to the sheep and goat industry. This report maintains the continuity of that effort and highlights recent technical advancements and scientific investigations dealing with animal production and management and with meat and fiber products.

Sheep and goat research in Texas is a consolidated effort involving the Main Station (at College Station), San Angelo, Sonora, and other field research sites. Scientists in Texas maintain close communication with scientists in other states, including those with the USDA. Additionally, linkages are established with research organizations in other countries where sheep and goat research is being conducted. Through this network, we maintain a prompt awareness of new developments and emerging technology which may be useful in Texas. The research program maintains relationships with private organizations involved with animal health-care products, feed supplements, ration additives, growth promotants, and other products and concepts which may be useful in sheep and goat production.

Research is carefully targeted to address priority needs. The Texas Agricultural Experiment Station maintains a five-year research plan in coordination with the sheep and goat industry. Research needs for 1986-1990 were recently reviewed by staff or members of the Texas Sheep and Goat Raisers Association, Mohair Council, Texas Angora Goat Raisers Association, breed associations, and others. This five-year plan for research is reviewed periodically to identify roll-forward changes based on new needs or shifts in priorities in the industry.

To a large extent, the order of the papers in this report reflects the priority and needs for research in Texas. Each section is prefaced by a short statement which places the research need in an industry perspective.

It is anticipated that this report will be distributed at field days and other events, in addition to distribution by district directors, specialists, and county agents with the Texas Agricultural Extension Service. The Experiment Station and Extension Service have several joint initiatives which are designed to assure that producers receive prompt, timely information that may impact on their operations and assist them in remaining economically viable.

Gary C. Smith, head
Department of Animal Science

Carl Menzies, Resident Director
TAMU Agricultural Research and Extension Center
at San Angelo

Sheep and Goat, Wool and Mohair--1986



Authors

Anderson, A. C., former graduate student,
Department of Veterinary Physiology and Pharmacology

Augustine, J. L., former graduate student,
Department of Veterinary Microbiology and Parasitology

Baldwin, B. C., Jr., research associate,
Texas Agricultural Experiment Station, San Angelo

Bales, K. W., research associate,
Texas Agricultural Experiment Station, San Angelo

Bassett, J. W., professor,
Department of Animal Science

Blackburn, H. D., research associate,
Department of Animal Science

Bowen, M. J., research associate,
Department of Veterinary Physiology and Pharmacology

Byers, E. M., associate professor,
Department of Animal Science

Calhoun, M. C., associate professor,
Texas Agricultural Experiment Station, San Angelo

Capelhart, J. S., research specialist,
Prairie View A&M University

Cartwright, T. C., professor,
Department of Animal Science

Cox, J., former student worker,
Texas Agricultural Experiment Station, San Angelo

Craig, T. M., professor,
Department of Veterinary Parasitology

Cross, H. R., professor,
Department of Animal Science

Edwards, J. E., assistant professor,
Department of Veterinary Pathology

Engdahl, B. S., technician,
Texas Agricultural Experiment Station, San Angelo

Engdahl, G. R., associate professor,
Agriculture Department, Angelo State University

Fister, R. D., student technician,
Department of Veterinary Microbiology and Parasitology

- Forrest, D. W.**, assistant professor,
Department of Animal Science
- Greene, L. W.**, assistant professor,
Department of Animal Science
- Huey, R. L.**, graduate assistant,
Department of Veterinary Parasitology
- Huston, J. E.**, associate professor,
Texas Agricultural Experiment Station, San Angelo
- Johnson, D. D.**, former instructor,
Department of Animal Science
- Johnson, H. K.**, vice president,
National Live Stock and Meat Board, Chicago, Illinois
- Jones, L. P.**, pathologist,
Texas Veterinary Medical Diagnostic Laboratory, College Station
- Juniewicz, P. E.**, research physiologist,
U. S. Department of Agriculture—Agriculture Research Service, Southwestern Livestock and Forage Research Station, El Reno
- Kim, H. L.**, assistant professor,
Department of Physiology and Pharmacology
- Kraemer, D. C.**, professor,
Department of Veterinary Physiology and Pharmacology and Department of Animal Science
- Kuhlmann, S. W.**, technical assistant,
Texas Agricultural Experiment Station, San Angelo
- Lewis, R. M.**, technician,
Texas Agricultural Experiment Station, San Angelo
- Lin, K. C.**, graduate assistant,
Department of Animal Science
- Lupton, C. J.**, associate professor,
Texas Agricultural Experiment Station, San Angelo
- Mankusa, M. M.**, graduate student,
Angelo State University
- McCown, C. S.**, coordinator of research,
MIR Center, Angelo State University
- Minhas, B. S.**, research scientist,
Biosyne Corporation, Houston, Texas
- Norris, T. A.**, graduate assistant,
Department of Animal Science
- Reeh, D.**, technical assistant,
Texas Agricultural Experiment Station, San Angelo
- Renshaw, H. W.**, former associate professor,
Department of Veterinary Microbiology and Parasitology
- Riley, R. R.**, manager,
Meat Science and Technology Center, Department of Animal Science
- Ripley, L. H.**, graduate student,
Texas Agricultural Experiment Station, San Angelo
- Sappington, S. R.**, graduate student,
Angelo State University
- Savell, J. W.**, associate professor,
Department of Animal Science
- Schelling, G. T.**, associate professor,
Department of Animal Science
- Shelton, J. M.**, professor,
Texas Agricultural Experiment Station, San Angelo
- Smith, G. C.**, head of department and professor,
Department of Animal Science
- Spiller, Don**, technician,
Texas Agricultural Experiment Station, Sonora
- Tiffany-Castiglioni, E.**, assistant professor,
Department of Veterinary Anatomy
- Thompson, P. V.**, research associate,
Texas Agricultural Experiment Station, San Angelo
- Ueckert, D. N.**, professor,
Texas Agricultural Experiment Station, San Angelo
- Wagner, K. A.**, graduate assistant,
Department of Animal Science
- Warner, D. H.**, student technician,
Department of Veterinary Microbiology and Parasitology
- Welsh, T. H., Jr.**, assistant professor,
Department of Animal Science
- Willingham, T.**, technician,
Texas Agricultural Experiment Station, San Angelo
- Zometa, C. A.**, former research scientist,
Texas Agricultural Experiment Station, San Angelo,
Texas (U.S. AID—SR-CRSP)

Contents

Foreword	inside cover
Authors	2
Five-Year Plan for Research and Development (1986-1990), The Texas Agricultural Experiment Station	7

Need 1. Increase Reproductive Efficiency

Productivity is closely related to lamb and kid crop percentages realized on the ranch. Reproduction research involves many aspects of production management, including genetic background, male reproductive capability, female potentials, herd management for cycling, efficient rebreeding, and reduction of reproductive diseases. Reports included in this document describe several facets of Texas Agricultural Experiment Station research aimed at improving the reproductive efficiency of sheep and goats.

PR-4371 Increasing Ovulation Rates of Rambouillet Ewes through Immunization Against Androstenedione	8
PR-4372 Increasing Ovulation Rate in Rambouillet Ewes through Inclusion of the Booroola Genotype as Compared to other Prolific Breeds	9
PR-4373 Real-Time Ultrasonic Scanning to Diagnose Pregnancy and Fetal Numbers in Sheep and Goats	10
PR-4374 Repeatability of Ovulation Rate in Rambouillet Ewes	13
PR-4375 Mineral Oil Drenching as a Possible Method to Increase Ovulation Rate	14
PR-4376 The Effect of Feeding on Ovulation Rate at Three Different Breeding Seasons ..	15
PR-4377 Developing Methods for Gene Transfer in Sheep	17
PR-4378 A Modified Technique for the Collection of Uterine Stage Sheep Embryos	17

Need 2. Decrease Predation Losses

Losses of domestic animals due to predation are a major problem in Texas. Predation presently limits geography of sheep and goat production. Domestic dogs and certain wildlife species kill sheep and goats, inflicting significant economic losses on individual ranchers. TAES has a research objective which involves reducing animal predations on domestic livestock by developing safe, effective, acceptable methods of protection or prevention.

PR-4379 The Use of Guard Dogs to Reduce or Prevent Predation on Sheep or Goats.	18
--	----

Need 3. Reduce Impact of Toxic and Harmful Plant Problems

Toxic plants limit productivity of sheep and goats, particularly in the Edwards Plateau. Death losses are estimated at \$2 to \$3 million each year; in addition, there are losses from poor reproduction, suppressed fiber production and inefficient animal gain. Research is targeted to development of effective and economical technology for diagnosing and managing disease conditions of sheep and goats resulting from toxic plants. Research includes grazing management, weed control, and other range improvement practices for Texas.

PR-4380 Acute Helenalin Toxicity in Sheep	21
PR-4381 Quantitation of Hymenoxon and Related Toxicants in Plant Samples	21
PR-4382 Bitterweed Antidotes Research	22

Need 4. Improve Prevention and Control of Infectious Diseases

The prevention and control of infectious diseases in sheep and goats are essential to maintain healthy flocks which produce efficiently. Death losses range from 0.5 to 5 percent annually and are caused by a wide number of disease problems, some of which may have spontaneous outbreak. Research in animal

management and veterinary medicine is targeted for effective prevention, control and therapeutic measures, including investigation of vaccines, rapid and accurate diagnostic procedures, and investigation of new diseases which may occur in the industry.

- PR-4383 Ovine Caseous Lymphadenitis: Disease Prevalence, Serologic Status, and Ovine Lymphocyte Antigen Type in a Population of Mature Culled Sheep 26
- PR-4384 Ovine Caseous Lymphadenitis: Lesion Prevalence and Serologic Status of a Population of Mature Culled Sheep..... 28

Need 5. Increase Adaptability and Productivity Under Prevailing Conditions

Too often, breeding males are selected from flocks or herds that have received favorable treatment (e.g., feeding). There is concern that, if this practice continues, subsequent generations of animals will lack adaptation to production conditions. Additionally, research must be conducted to characterize performance/productivity under existing, often limiting conditions (mineral imbalance, shortages of forage, inadequate supplies of energy or protein, presence of genetic anomalies in the herd, etc.). Producers need help to be able to produce sheep and goats under whatever conditions prevail.

- PR-4385 A Survey of the Selenium Status of Sheep on the Edwards Plateau of West Texas .29
- PR-4386 Dexamethasone-induced Suppression of Adrenocorticotropin (ACTH) and Cortisol Secretion in Rams 29
- PR-4387 Effects of Season of Birth, Dietary Energy Level, and Lasalocid on the Performance of Sheep 30
- PR-4388 Evaluation of Fourwing Saltbush as an Alternative Forage for Goats..... 33
- PR-4389 Effect of Protein Supplementation on Ewe Performance, Forage Intake, Lamb Survival, and Growth 33
- PR-4390 Evaluation of the Potential for Chemical Castration of Angora Males 34
- PR-4391 A Reoccurrence of the “Silky” Mutant in Sheep 35

Need 6. Increase Economic Efficiency of Forage and Feed Utilization

Production costs and animal performance are largely dependent upon range management, utilization of native forage species, and feedlot performance. Supplemental feeding is an economic alternative in some situations to improve animal performance; it is particularly useful to increase lamb or kid crops or to advance animal growth when merited by prices. Sheep and goat nutrition is directly related to management practices as the most efficient means of improving performance.

- PR-4392 The Effect of Supplemental Feeding on Roughage Utilization by Sheep. 37
- PR-4393 Effects of Lasalocid, Energy and Protein on Performance of Ewe Lambs 38
- PR-4394 The Individual and Combined Use of Antibiotic Feed Additives in Lamb Finishing Rations 41
- PR-1395 Forage and Total Nutrient Intake in Kid, Yearling, and Adult Angora Goat Fed Three Levels of Supplemental Energy 44
- PR-4396 A Comparison of Rumensin and Bovatec at Increasing Levels in Supplemental Feed for Lambs and Angora Kids on Rangeland..... 45
- PR-4397 Intake and Digestibility in Sheep and Goats Fed Three Forages with Different Levels of Supplemental Protein 46
- PR-4398 Magnesium, Potassium, and Calcium Absorption and Retention in Sheep Fed Monensin and Potassium 48

Need 7. Increase Fiber Production, Quality, and Value

Texas ranks first in the nation in wool and mohair production. At present, sale of wool and the associated incentive payment constitute almost one-third of gross income from sheep; wool and mohair together comprise more than half of gross income from Texas production of sheep and goats. TAES research

emphasizes effects of genetic, environmental, management, and nutritional inputs and influences on quantity and quality of wool and mohair and seeks more objective means for describing fiber quality.

PR-4399	Variability of Staple Length in Short-Shorn Wools	52
PR-4400	Some Fleece and Fiber Characteristics of Texas Karakul Sheep.....	56
PR-4401	Variation in Wool Fiber Diameter from Tip to Base Among Rambouillet Rams on Performance Test.....	56
PR-4402	Kemp Fiber Measurements	59
PR-4403	Review: Genetics and Management of Kemp in Mohair	60

Need 8. Improve Consumer Acceptability of Sheep and Goat Meat

Approximately two-thirds of the income from the sheep industry comes from the sale of slaughtered animals. The meat value of Angora goats is also significant for Texas ranchers. Overall, the industry is faced with low carcass weights and meat yields and small-sized cuts of meat, representing certain inefficiencies in the production, processing, and marketing of lamb and goat products. The research objective is to improve the production and marketing technology of lamb, mutton, and goat meat and related products. Processing techniques, consumer acceptance, and improved market channels are included in the TAES research scope.

PR-4404	Carcass Grades, Rack Composition, and Tenderness of Sheep and Goats as Influenced by Market Class and Breed	67
PR-4405	New Concepts in Marketing and Merchandising Lamb	70
PR-4406	Carcass Composition of Lambs from the United States and New Zealand.....	74
PR-4407	Nutrient Composition of U.S. and New Zealand Lamb	76

Need 9. Improve Prevention and Control of Internal and External Parasites

Nearly all commercial sheep and goat flocks are infested with internal and external parasites. Parasitism may be particularly severe in periods of heavy rain/warm weather or when animals are under stress from food shortages or weather conditions. TAES investigations concentrate on the control of internal and external parasites, including new therapeutic and control measures for parasitism, evaluation of anthelmintics, and investigation of pest management systems.

PR-4408	Evaluation of the Efficacy of Rumensin for Controlling Coccidiosis in Angora Goats.....	79
PR-4409	Safety of Rumensin as a Coccidiostat for Angora Goats.....	82

Need 10. Develop Decision Aids for Optimal Production Systems

Mathematical expressions of sheep and goat production responses to alternative management practices are needed to develop computer software to allow producers to make decisions which will optimize production efficiency and minimize risk in utilizing resources. TAES research in this arena presently centers upon computerizing the decision-making processes in nutrition management and use of modeling to allow simultaneous consideration of all facets of production as alternative practices are considered.

PR-4410	Computerized Decision Aids in Nutrition Management of Range Sheep.....	82
PR-4411	A Conceptual Overview of The TAMU Sheep Production Model.....	83

**Five-Year Plan (1986-1990)
for Research and Development,
The Texas Agricultural Experiment Station**

Sale of sheep and goats, wool and mohair in Texas produced \$156 million in income during 1985 for producers, provided employment for workers in many associated professions, diversified income to ranchers, and contributed to more efficient utilization of rangeland and feed resources. The ecological benefits of mixed species grazing (cattle, sheep, goats and wildlife) are of particular importance to the unique rangeland resource in Texas. Sheep and goat production requires low inputs of fossil fuel and cereal grains. This, along with the unique opportunity the animals provide for utilizing feed resources, their relatively high reproduction potential, and a stable consumer demand for their meat and fiber, indicate their continued contribution to Texas agriculture.

The greatest opportunity for improving productivity and income is by increasing reproductive efficiency. Reproduction can be increased through improved nutrition, genetic selection, management, and herd health. Major limitations that can be assisted through research include predation, toxic plants, infectious diseases and parasites. Research can develop improved production and marketing technology for meat, wool and mohair. Computers offer a means for developing programs to aid producers in making management decisions. An effective research program for sheep and goats includes cooperative interaction of scientists from several disciplines, including animal science, veterinary medicine, range science and wildlife science.

Available resources and production parameters are largely unique to Texas; thus much of the research on sheep and goats must be conducted locally. These industries are currently centered in the Edwards Plateau but in the past have extended to adjacent resource areas, and the potential exists to re-establish significant sheep and goat production in much of the state.

Priority Needs

- (1) Increase Reproductive Efficiency
- (2) Decrease Predation Losses
- (3) Reduce Impact of Toxic and Harmful Plant Problems
- (4) Improve Prevention and Control of Infectious Diseases
- (5) Increase Adaptability and Productivity Under Prevailing Conditions
- (6) Increase Economic Efficiency of Forage and Feed Utilization
- (7) Increase Fiber Production, Quality, and Value
- (8) Improve Consumer Acceptability of Sheep and Goat Meat
- (9) Improve Prevention and Control of Internal and External Parasites
- (10) Develop Decision Aids for Optimal Production Systems

Increasing Ovulation Rates of Rambouillet Ewes Through Immunization Against Androstenedione

T. A. Norris, D. W. Forrest, and M. Shelton

A major concern to the sheep producer is the reproductive efficiency of his flock. One possible means of improving reproductive efficiency is to increase the production of twins. This can be accomplished by introducing multiple-lambing breeds such as the Booroola, but this requires a long-term commitment to a breeding program. Another approach is steroid immunization, a technique which was developed in Australia in the last decade and can be implemented prior to the onset of the breeding season. Since 1982 a commercial product called Fecundin (available in the United Kingdom) has been used to increase ovulation rate and the number of lambs produced by immunizing ewes against an ovarian steroid, androstenedione.

A study is being conducted using a product similar to Fecundin, which is not available in the United States, to determine if immunized Rambouillet ewes have increased ovulation rates and produce more lambs than controls. Antibody titers were determined since the procedure stimulates the production of antibodies against androstenedione.

In late September 1985, 34 Rambouillet ewes, 4 years of age, were divided into four groups. Two groups, each with nine ewes, received a subcutaneous injection of 2 mg androstenedione bound to a carrier protein, bovine serum albumin (A-BSA). In addition, an adjuvant was mixed with the steroid-protein conjugate to increase the production of antibodies. The two control groups, containing eight ewes each, received a solution of BSA and adjuvant. The adjuvant given to one treatment and one control group was Freund's complete adjuvant (A-BSA-F and BSA-F, respectively). The other treatment and control groups were given the adjuvant DEAE dextran (A-BSA-D and BSA-D, respectively). A booster injection was given 3 weeks after the primary immunization. This booster injection was identical to the primary immunization except that in the A-BSA-F and BSA-F groups, Freund's incomplete adjuvant was mixed with the steroid-protein conjugate.

Two weeks after the booster (5 weeks after the primary immunization) rams were joined with the ewes. The rams were fitted with marking harnesses and the ewes were observed daily for breeding marks. Ovulation rates were determined by examining the ovaries using a laparoscope and counting the number of corpora lutea observed 5-13 days post-breeding. When rams were introduced, blood samples were collected to determine antibody titers. Treatment ef-

Table 1. Effect of immunization against androstenedione on production of antibodies and ovulation rate in Rambouillet ewes

Treatment	Mean antibody titer* (range)	Mean ovulation rate (\pm SEM)
A-BSA-F	1:795 (1:92-1:2817) ^a	2.00 (\pm .18) ^a
A-BSA-D	1:22 (1:1-1:152) ^b	1.56 (\pm .18) ^a
BSA-F	nondetectable ^b	1.57 (\pm .21) ^a
BSA-D	nondetectable ^b	1.87 (\pm .19) ^a

*Antibody titer is expressed as the dilution ratio of serum to buffer. A higher dilution indicates more antibodies present.

^{a,b}Means in the same column with different superscripts are different ($P < .05$).

fects on mean ovulation rate were determined by analysis of variance and correlations were calculated to determine the relationship between antibody titers and ovulation rate. The results are shown in Table 1.

These data indicate that immunization against androstenedione did not significantly increase ovulation rates. Yet, there is a positive correlation ($r = .47$, $P < .005$) between antibody titer and ovulation rate. Thus, the absence of an increase in ovulation rate in the A-BSA-D group compared with the controls (BSA-D and BSA-F) can be explained by the low antibody production.

In conclusion, steroid immunization appears to stimulate multiple ovulations in Rambouillet ewes. It remains to be determined if the lambing rate is affected. The possibility of increasing lamb production through steroid immunization requires further investigation to determine the proper immunization techniques and the repeatability of the ovulation/lambing response.

PR-4372

Increasing Ovulation Rate in Rambouillet Ewes Through Inclusion of the Booroola Genotype as Compared to Other Prolific Breeds

T. Willingham, M. Shelton,
D. Spiller, and P. Thompson

Summary

The inclusion of the Booroola gene into a crossbreeding program with Rambouillet ewes resulted in an increase of 0.94 in ovulation rate for those ewes carrying a single copy of the gene. With this increase in mean ovulation rate, an increase in the

number of ewes having triplet or more ovulations occur. Forty-three percent of the ewes that were heterozygous for the F gene had three or more ovulations while only two percent of the Rambouillet ewes had three or more ovulations. With the observed increase in ovulation rate approximately 43 additional lambs per 100 ewes might be expected. This is a calculated value utilizing estimates of embryo wastage from past experiments. Ewes having 50 percent Finn breeding had an ovulation rate of 0.37 less than the Booroola Merino cross ewes and 0.57 greater than straight Rambouillet ewes. Seventeen percent of the Finn cross observations were in the ovulation rate category of three or more. The use of the Booroola gene in local breeds offers definite opportunities for improving reproductive potential.

Introduction

Increasing the reproductive performance provides a primary opportunity to improve the income and competitive position of the U.S. sheep industry. Since it is generally recognized that the ovulation rate sets the upper limit for the number of lambs born at any parturition, it would follow that breeding for increased ovulation rate would improve the number of lambs born. However, the ovulation of an ovum does not insure that a lamb will be born or reared.

In past years, a few producers have tried using prolific breeds such as the Finnish Landrace in crossbreeding programs with variable results. One potential concern from this approach is that the use of a breed such as the Finn alters the performance of the animal in respect to adaptability and fleece traits. One purpose of this study was to evaluate the potential of the Booroola gene introduced into local sheep breeds.

Booroola is a term used to identify a type of Merino originating in Australia which carries a single gene trait for increased fecundity. The genetic makeup of a Booroola or Booroola cross population will exist in one of three forms: 1) FF (double copy of the gene) homozygous carrier, 2) F- (single copy) heterozygous carrier, and 3) — (no copy) homozygous non-carrier. The allele F represents the gene for increased fertility. Even pure Booroolas are not all homozygous for the gene. Action of the gene on ovulation rate is not completely understood at present, but an additive effect of the gene has been suggested (1,2).

Experimental Procedure

In the fall of 1982 and 1983 six breeding groups were set up at the Winters Ranch near Brady or the Hill Ranch in Edwards County. The breeding groups were composed of commercial Rambouillet ewes bred to sires from one of six breeds or breed groups. The sire breeds consisted of Booroola Merino, Booroola x Coopworth, Dorset, Finnish Landrace, Polypay and Rambouillet. The Booroola Merino sire was unavailable for use in 1983. The Booroola x Coopworth sires used were believed to be heterozygous carriers for the F gene based on pedigree. Lambs produced from each cross were permanently identified and handled in a traditional manner. Upon weaning, all ewe lambs were

maintained on pasture at Brady or at San Angelo. Those animals at San Angelo were maintained on oat pasture for a period of time as lambs.

In the fall of 1984, 150 head of yearling crossbred ewes originating from the 1982 breeding were maintained on pasture and checked for estrus three times per week for two estrous cycles. Ewes were exposed to sterile males for the first estrus and bred to a fertile male at the second estrus. Epididymectomized rams wearing a sire sine marking harness were used in the first estrus detection and harnessed fertile males were used for the second estrus detection.

Ewes exhibiting estrus were examined 5-10 days later for number of corpora lutea (CL) present by the laparoscopic technique. The laparoscopic procedure (3) provides a rapid means for determination of the ovulation rate.

The same procedure was used in the fall of 1985 on 125 yearling ewes from the 1983 breeding season for 2 estrual cycles and for 1 estrus period for the 150 2-year-old ewes.

Results and Discussion

The location from which the sheep originated did not show a statistical effect on ovulation rate (OR) and in subsequent analysis this was deleted from the model. Table 1 indicates the mean OR for ewes bred as yearlings to lamb as 2-year-olds. The data used for this table includes two years of observations on yearling animals with the exception that the Booroola Merino (M) sired animals were available for only one year. Those animals of M origin had significantly higher OR than any of the other breeds as yearlings.

Table 2 contains data for ewes bred as 2-year-olds to lamb as 3-year-olds. Significant differences were observed between the breeds with those containing Booroola or Finn breeding showing a higher ovulation rate than other types.

Table 3 contains the pooled data for all observations. Ewes of M breeding had an improvement of 0.94 OR over Rambouillet (R) ewes. The M ewes were believed to be out of a homozygous carrier for the F gene. If this were true, each ewe would carry a single copy of the gene or would be a heterozygote. No more than one half of the Booroola x Coopworth (C) sired ewes could be carriers of the gene. Thus, theoretically, one half would be heterozygous with the other half being homozygous non-carriers. Since the Booroola gene is a single gene trait that appears to behave in an additive manner for OR, we would expect the C ewes to be intermediate to the M and R ewes in OR. The mean OR for C ewes was 1.94 which was 0.48 greater than R ewes and 0.46 less than the M ewes. Showing half the gain of the M sired ewes was the expected result based on the assumption that the one quarter Coopworth in the genotype is not influencing the OR. Producers may be tempted to conclude that the 0.48 increase approximates that which is desired. However, it should be pointed out that this cannot be applied to individual ewes. They are either carriers or are not carriers and thus when applied to an individual ewe, the increase is likely to be the larger value or no increase at all.

Table 1. Mean yearling ovulation rate (2 observations per animal)

Sire breed	Number of animals	Ovulation rate
Booroola Merino	12	2.29 ^a
Finnish Landrace	63	1.98 ^{b1}
Booroola Coopworth	49	1.93 ^b
Dorset	29	1.46 ^c
Rambouillet	65	1.44 ^c
Polypay	39	1.17 ^d

Means with different superscripts are significantly different (P<.05).

Table 2. Mean two-year-old ovulation rate (1 observation per animal)

Sire breed	Number of animals	Ovulation rate
Booroola Merino	11	2.64 ^a
Finnish Landrace	51	2.14 ^{ab}
Booroola Coopworth	21	2.00 ^{bc}
Dorset	7	1.00 ^d
Rambouillet	40	1.52 ^{cd}
Polypay	16	1.25 ^d

Means with different superscripts are significantly different (P<.05).

Table 3. Pooled mean ovulation rate

Sire breed	Number of observations	Ovulation rate
Booroola Merino	35	2.40 ^a
Finnish Landrace	177	2.03 ^b
Booroola Coopworth	119	1.94 ^b
Dorset	64	1.41 ^c
Rambouillet	170	1.46 ^c
Polypay	94	1.18 ^d

Means with different superscripts are significantly different (P<.05).

Ewes of Booroola or Finn genotypes had a greater percentage of three or more ovulations. This should be of some concern to the producers as a percentage of these triplet ovulations will result in triplet births, but with each increase in ovulation rate the probability that all ovum will produce a lamb decreases. However, some triplet or larger litter sizes will be produced and a producer should be aware of this possibility. This may or may not be considered a disadvantage depending on the management conditions.

The results of this study suggest that inclusion of the Booroola genotype in Rambouillet ewes can improve ovulation rate by approximately 0.94 over the straight Rambouillet ewe. This improvement in ovulation rate could theoretically mean an increase of 43 lambs per 100 ewes since it has been suggested (4) that for each unit increase in ovulation rate an increase of 0.46 lambs born might be expected. The actual gains in

lambs born to Booroola x Rambouillet ewes would be expected to differ as a result of increased embryonic mortality or fertilization failure.

Literature Cited

1. Davis, G.H., G.W. Montgomery, A.J. Allison, and P.W. Kelley. 1982. A test of the hypothesis that progeny of Booroola sheep segregate in the ratio expected from a single gene controlling fecundity. *N.Z. Jour. Agr. Res.* 25.
2. Piper, L.R. and B.M. Bindon. 1982. Genetic segregation for fecundity in Booroola Merino sheep. *Proc. World Congress on Sheep and Beef Cattle Breeding* 1:395.
3. Seeger, K.H. and P.R. Klatt. 1980. Laparoscopy in the sheep and goat. *In: Animal Laparoscopy*, pp. 107-120. Williams and Wilkins, Maryland.
4. Willingham, T.D., M. Shelton, and P. Thompson. 1985. An assessment of reproductive wastage in sheep. Unpublished data.

PR-4373

Real-Time Ultrasonic Scanning to Diagnose Pregnancy and Fetal Numbers in Sheep and Goats

R.M. Lewis, T.D. Willingham, and M. Shelton

Summary

Approximately 500 sheep and goats were diagnosed for pregnancy and litter size using real-time ultrasonic scanning instrumentation to evaluate the usefulness of this technology as a management tool. Accuracies of the diagnoses were determined by comparing the scan results to lambing and kidding records on the experimental animals. Although pregnancy diagnosis was fairly accurate throughout gestation, pregnancy being correctly diagnosed in more than 93 percent of the examinations, attempts to correctly determine fetal numbers were less successful. Errors in litter size diagnoses were reduced by approximately 10 percent when scans were conducted between 40 and 70 days of gestation. The clarity of the image, in addition to the gestational stage of the animal, contributed to the likelihood that a given diagnosis would be correct.

Introduction

Accurate diagnosis of pregnancy and litter size in sheep and goats would provide valuable information on which to base breeding and management decisions within a flock (4). Single and multiple lamb bearing ewes could be identified and managed appropriately (1,5). Furthermore, dry ewes could be separated from the remainder of the flock or culled. This technology is

also potentially useful for the study of the problem of abortion in Angora goats; nannies who fail to kid could be classified as either having failed to mate or having aborted allowing for more appropriate management or culling decisions. In breeding programs emphasizing prolificacy, litter bearing ewes could be identified without dependence on the laborious and occasionally erroneous pairing of lambs and their dams at birth (5).

Many techniques for determining pregnancy and fetal numbers have been studied (1,2,3,5). Although several are valuable in pregnancy diagnosis, few have proved to be cost effective for extensive use by the industry. No sufficiently efficient or accurate techniques have been developed to date for determination of litter size in sheep and goats. One technology introduced only recently to the sheep industry, real-time ultrasound imaging, has been suggested to overcome these shortcomings. Fetal shape, structure and movement are depicted on a screen, through the instantaneous and continuous imaging of internal anatomy, allowing for a visual differentiation of fetuses. The intent of this study was to examine the merits of real-time ultrasound imaging as an accurate and rapid method for diagnosing pregnancy and, more specifically, litter size in sheep and Angora goats.

Experimental Procedure

Three hundred and thirty-nine Rambouillet and 24 Finnish Landrace ewes and 129 Angora nannies were examined over a two month period beginning in early November 1983. These animals were scanned at various stages in their gestation producing a total of 522 diagnoses: some ewes and nannies were scanned twice with these observations included in the total. Two technicians participated in the trial, and both were inexperienced with real-time ultrasound imaging at the start of the project. Each technician examined approximately one half of the animals. A Bion Equiscan 4100 real-time ultrasound scanning instrument with a 3 MHz frequency transducer was used in the experiment.

Animals were held off feed and water the night preceding the examination. Each examination was conducted while the animal was restrained on her back in a cradling device. An external probe was used with the transducer applied to the animal's shorn lower abdominal and flank regions. The average duration of examination was 1½ minutes. The technicians attempted to diagnose pregnancy and determine the number of fetuses carried. Once lambing and kidding data became available, the accuracy of the diagnoses was determined by comparing the scan and birth records. Some errors were likely introduced into the study by the mispairing of young at birth. An overall diagnosis accuracy was estimated by comparing the total number of correct scans to the total number of scans.

Results and Discussion

The accuracies of diagnosis of litter size during various stages of gestation for ewes and nannies are listed in Tables 1 and 2. The accuracies are particularly

Table 1. Accuracy of determination of fetal numbers as affected by stage of gestation in ewes

Stage of gestation	Number of scans			Accuracy ^a (percent)
	Correct	Incorrect	Total	
0-30	1	19	20	5.0
31-40	12	10	22	54.5
41-50	28	6	34	82.3
51-60	74	15	89	83.1
61-70	47	13	60	78.3
71-80	20	8	28	71.4
81-100	41	21	62	66.1
101-120	29	8	37	78.4

^aAccuracy refers to the number of correct scans per total scans expressed as a percentage.

Table 2. Accuracy of determination of fetal numbers as affected by stage of gestation in Angora nannies

Stage of gestation	Number of scans			Accuracy ^a (percent)
	Correct	Incorrect	Total	
0-30	1	2	3	33.3
31-40	1	2	3	33.3
41-50	29	8	37	78.4
51-60	18	2	20	90.0
61-70	24	2	26	92.3
71-80	62	6	68	91.2
81-90	12	1	13	92.3

^aAccuracy refers to the number of correct scans per total scans expressed as a percentage.

low preceding 40 days gestation in both species (less than one-half of the diagnoses were correct). Relatively few scans, however, were conducted during this period. The generally higher accuracy rates realized in the Angoras, when compared to the ewes, are likely the consequence of fewer nannies bearing twins. The optimal time for scanning in sheep appears to be between 40 and 70 days of gestation, with accuracy decreasing thereafter. In the Angora, diagnoses on nannies scanned as late as 90 days gestation were accurate approximately 90 percent of the time.

Determining pregnancy is fairly accurate irrespective of the number of days bred; more than 93 percent of these diagnoses were correct. Accuracies were further improved if the examination was made between days 40 and 70 and between days 40 and 90 in sheep and goats, respectively (Tables 3 and 4). The error in differentiating single from multiple fetus bearing animals was also reduced by approximately 10 percent during these periods. Only 17.6 percent of the diagnoses of non-pregnant nannies were correct. These errors were all generated in one flock that was returned to range following scanning. An additional group of nannies were instead confined in feeder pens following examination and closely monitored for abortion; although several of these nannies did abort, none diagnosed as pregnant failed to bear a kid. Therefore, it seems likely that at least a portion of the 14 nannies which were diagnosed as pregnant and did not kid had

Table 3. Accuracy of diagnosis of pregnancy and single versus multiple fetuses in ewes either 40 to 70 days gestation or throughout gestation

Number of lambs	Diagnoses between 40-70 days gestation			Diagnoses throughout gestation ^a		
	Correct	Incorrect	Accuracy ^b (percent)	Correct	Incorrect	Accuracy ^b (percent)
0	0	0	0	20	13	60.6
1 or more	182	3	98.4	332	25	93.0
0	0	0	0	20	8	71.4
1	84	15	84.8	132	42	75.9
2 or more	67	19	77.9	120	55	68.6

^aAll diagnoses are included in the category regardless of the number of days gestation.

^bAccuracy refers to the total number of correct scans per total scans expressed as a percentage.

^cNon-pregnant ewes are excluded from this category.

Table 4. Accuracy of diagnosis of pregnancy and single versus multiple fetuses in Angora nannies either 40 to 90 days gestation or throughout gestation

Number of lambs	Diagnoses between 40-90 days gestation			Diagnoses throughout gestation ^a		
	Correct	Incorrect	Accuracy ^b (percent)	Correct	Incorrect	Accuracy ^b (percent)
0	0	0	0	3	14	17.6
1 or more	159	5	97.0	164	6	96.5
0	0	0	0	3	14	17.6
1	136	11	92.5	138	15	90.2
2	9	8	52.9	9	8	52.9

^aAll diagnoses are included in the category regardless of the number of days gestation.

^bAccuracy refers to the total number of correct scans per total scans expressed as a percentage.

^cNon-pregnant nannies are excluded from this category.

aborted on range. Thus, this technique may be useful for the study of the abortion problem in goats.

Although pregnancy diagnosis was accurate using real-time ultrasound imaging, our accuracy in determining litter size was less than expected, even during the more optimal scanning period. In sheep, for instance, multiple fetuses were correctly diagnosed with only a 78 percent accuracy during the optimal scanning period. The accuracies of the two technicians were quite similar, and although their inexperience with the technology was likely a source of error in earlier scans, incorrect diagnosis may be the consequence of the stage of gestation and sensitivity or clarity of the scanning device rather than solely technician error. Accuracies reported by other researchers have been considerably better than those of this trial, even among novice technicians, although none has worked with the specific instrument employed in this study (1,5). Although our preliminary work with real-time ultrasound imaging has not been entirely successful in determining fetal numbers, it is believed that with additional refinements in instrumentation, this technology will likely serve a role in flock management.

Literature Cited

1. Fowler, D.G. and J.F. Wilkins. 1984. Diagnosis of pregnancy and number of fetuses in sheep by real-time ultrasonic imaging. I. Effects of number of foetuses, stage of gestation, operator and breed of ewe on accuracy of diagnosis. *Livestock Prod. Sci.* 11:437.
2. Hulet, C.V. 1969. Pregnancy diagnosis in the ewe using an ultrasonic doppler instrument. *J. Anim. Sci.* 28:44.
3. Hulet, C.V. 1972. A rectal abdominal palpation technique for diagnosing pregnancy in the ewe. *J. Anim. Sci.* 35:814.
4. Parker, C.F. and A.L. Pope. 1983. The U.S. sheep industry: changes and challenges. *J. Anim. Sci.* 57(Suppl. 2):75.
5. White, I.R., A.J. Russel, and D.C. Fowler. 1984. Real-time scanning and diagnosis of pregnancy and the determination of fetal numbers in sheep. *Vet. Rec.* 115:140.

Repeatability of Ovulation Rate in Rambouillet Ewes

T. Willingham, M. Shelton, and P. Thompson

Summary

A total of 112 Rambouillet ewes were used to determine the repeatability of ovulation rate from 3 consecutive estrous cycles by use of laparoscopy. The average ovulation rates per ewe for the 3 estrous periods were 1.43, 1.52 and 1.41 with an overall average of 1.46. Using intra-class correlation, a pooled repeatability value of $.243 \pm .06$ was calculated ($P < .05$). Variation did occur in the ovulation rate between the consecutive estrous cycles; however, a tendency for either low or high ovulation rate was evident for animals separated by initial ovulation. These data suggest that laparoscopic observation of the ovaries for corpora lutea (CL) could be used to intensify selection for ovulation rate and potential lambing rate.

Introduction

The reproductive efficiency of ewes is determined by ovulation rate, fertilization failure, ova wastage and embryo or lamb mortality. It is generally recognized that ovulation rate sets the upper limit for the number of lambs produced at a given parturition. Much of the current interest is centered around improving lamb production through genetic means. Direct and repeat observations of the ovulation rate provides a rapid or early means of appraising the ovulation rate as contrasted to the time required to accumulate a period of years lambing records. However, in the evaluation of this technique it is important to consider the repeatability of ovulation rate, since (6) "Repeatability is a concept closely related to heritability and is useful for those traits which are expressed several times during an animal's lifetime. Since neither the genes nor gene combinations influencing the successive expressions of a trait change, repeatability should be at least as large as heritability in the broad sense."

Experimental Procedure

Three groups of Rambouillet ewes, totaling 112 head, were used to evaluate repeatability of ovulation rate. Ewes were randomly sorted into three groups. Group 1 ewes were managed at the San Angelo Center in dry lots. Ewes were group fed a mixture of cotton gin waste and a salt limited supplement every third day, with total intake approximating the NRC requirement for sheep. Group 2 was held on native pasture at the Winters Ranch in Brady, while Group 3 was maintained on pasture at San Angelo.

Epididymectomized rams were painted anterior to the prepuce and used in estrus detection for the first two estrous cycles. Ewes exhibiting estrus were record-

ed daily and examined 6 to 12 days later for number of CL present by laparoscopy. All ewes were bred to fertile males on the third estrus.

Chi-square analysis was performed to determine differences in ovulation between groups. Repeatability estimates for ovulation rate were derived by use of intra-class correlations (1). Repeatability estimates were also calculated using an alternate method (2,4). Estimates from both procedures were similar; however, only those estimates calculated by the procedure presented by Becker (1) will be presented since it includes a clear method of testing for significance.

Results and Discussion

The pooled repeatability estimate of ovulation rate (.342) obtained in this study (Table 1) is very similar to the .32 estimate reported earlier (3) for Merino ewes.

Variation in repeatability estimates and ovulation rate (Tables 1 and 2) did occur between groups. The variation in ovulation rate between groups should be due to chance or environmental and management differences since all ewes originated from the same flock and were randomly assigned.

In evaluating the pooled estimate of .342, we would expect an average repeatable difference of 34.2 percent in ovulation rate between ewes with single and multiple ovulations when examined over 3 estrous cycles. A larger difference of 56.0 percent would be expected as indicated in Table 3 when ewes are sorted into single or multiple groups according to their first 2 ovulations.

Table 2 shows the number of corpora lutea observed, thus giving the ovulation rate and potential lamb production; however, one should not expect to achieve lambing rates as high as ovulation because of various reproductive failures. The mean ovulation rates for all groups by observation are 1.43, 1.52, and 1.44 with an overall average of 1.46. This is slightly below the mean ovulation of 1.50 reported elsewhere (5) and may result from age variation as mature ewes were evaluated over 4 years; but the difference is slight.

Significant differences ($P < 0.01$) between groups were found for ewes examined in this study. Ewes located at Brady had consistently lower ovulation rates, which may result from a lower nutritive level due to poorer pastures. These differences are reflected in group repeatability values but are removed from the pooled estimate through statistical correction.

Table 3 shows the effect of selection for ovulation

Table 1. Repeatability of ovulation

Group	Repeatability estimate	S.E.
Angelo dry lot	.415*	$\pm .098$
Brady pasture	.212*	$\pm .094$
Angelo pasture	.449*	$\pm .087$
Pooled	.342*	$\pm .060$

*Significant at ($P < .05$)

Table 2. Number of corpora lutea observed

Group	No. of animals	1st observation			2nd observation				3rd observation		
		1CL	2CL	Avg. CL per ewe	1CL	2CL	3CL	Avg. CL per ewe	1CL	2CL	Avg. CL per ewe
Angelo dry lot	40	20	19	1.48 ^{ab}	13	26	1	1.70 ^a	16	24	1.60 ^a
Brady pasture	48	34	14	1.29 ^b	33	15		1.31 ^b	34	14	1.29 ^b
Angelo pasture	24	9	15	1.63 ^a	9	15		1.63 ^a	13	11	1.46 ^{ab}
Total		64	48		55	56	1		63	49	
Average ovulation rate		1.43			1.52				1.44		

Values in "Avg. CL per ewe" columns with different superscripts are significantly different ($P < .01$).

Table 3. Subsequent ovulation rate of ewes when sorted by observation

Group	Percent ovulation rate	
	At 2nd observation	At 3rd observation
Ewes having 200% ovulation rate at 1st observation	173	167
Ewes having 100% ovulation rate at 1st observation	138	127
Difference	35.0	40.0
Ewes having 200% ovulation rate at 2nd observation	—	161
Ewes having 100% ovulation rate at 2nd observation	—	125
Difference	—	36.0
Ewes having 200% ovulation rate at 1st and 2nd observation	—	179
Ewes having 100% ovulation rate at 1st and 2nd observation	—	123
Difference	—	56.0

rate on subsequent ovulation rates. Ewes selected for multiple ovulation at either the first or second observation had 35 percent, 40 percent and 36 percent greater ovulation rates than those ewes separated as single ovulating animals. This difference increased to 56 percent when ewes were separated into multiple (179 percent) and single (123 percent) groups after 2 observations, indicating a tendency for similar ovulatory patterns after one observation and increasing the magnitude with increased observations.

These results indicate that since a moderate repeatability of .342 exists, improvement in ovulation rate can be realized through selection. The laparoscopy technique allows for much more rapid realization of this trait than selection from lambing records over a period of years, and accuracy of selection would improve with number of observations taken.

Literature Cited

1. Becker, W. A. 1967. Manual of procedures in quantitative genetics (2nd Ed.), pp. 1-5. Washington State University, Washington.
2. Davenport, R. L., H. H. Stonaker, K. Riddle, and T. M. Sutherland. 1965. Heritability of reproductive performance in inbred and linecross beef cows. *J. Anim. Sci.* 24:434.

3. Davis, G. H., G. W. Montgomery, and R. W. Kelly. 1982. Estimates of the repeatability of ovulation rate in Booroola cross ewes. Mimeograph. New Zealand.
4. Lush, J. S. 1950. Inheritance of susceptibility to mastitis. *J. Dairy Sci.* 33:121.
5. Shelton, M. and P. Thompson. 1980. Partitioning the losses in reproductive efficiency in fall-bred range finewool ewes. *Tex. Agri. Expt. Sta. PR-3701.*
6. Warwick, E. J. and J. E. Legates. 1979. Breeding and improvement of farm animals (7th Ed.), p. 100. McGraw-Hill Book Co., New York.

Acknowledgements

A portion of this research was carried out as a part of the United States Agency for International Development Title XII Small Ruminant Collaborative Research Support Program under Grant No. AID/D-SAN/XII-G-0049.

PR-4375

Mineral Oil Drenching as a Possible Method to Increase Ovulation Rate

T. Willingham, M. Shelton,
and Phil Thompson

Increasing lamb production through improved ovulation rate or preventing wastage of those ova shed should be a major priority of the sheep producing community. Based on research results from another institution, the oral administration of mineral oil has been suggested as a possible method to improve ovulation rate. The actual mechanism of action in mineral oil is unknown, but it may act to lessen the negative feedback of steroids and increase gonadotropic hormones.

The use of mineral oil drenching as a flushing agent, beginning 12 days after the previous estrus and continuing to estrus detection, has been evaluated at the San Angelo Center and Winters Ranch in Brady.

Epididymectomized rams were used to detect estrus, with mineral oil treatment beginning 12 days after marking and ending at subsequent estrus. Mineral oil was administered in 50 ml doses by using a standard drench gun daily until marked by rams a second time. Ovulation rate was determined 5 to 6 days after marking by use of the laparoscopic technique. Data were evaluated by chi-square analysis.

In this study, there was no evidence that the administration of mineral oil increased ovulation rate. This is contradictory to previous research and may be due to the short period of drenching involved when compared to others in which mineral oil was administered daily throughout the estrous cycle.

PR-4376

The Effect of Feeding on Ovulation Rate at Three Different Breeding Seasons

T. Willingham and M. Shelton

Summary

An experiment was conducted using 144 finewool ewes to evaluate the effect of feeding prior to mating at 3 time periods, early (June to September), middle (September to October), and late (November to December) in the breeding season. Early season feeding had the greatest impact on increasing ovulation rate, while mid- and late season feeding showed a smaller, though similar response. However, increases in ovulation rate were not found to be significant for any of the three time periods. Beginning body weights, weight

change, body weight nearest ovulation, and final weight were positively, but not significantly ($P > .05$), correlated to ovulation rate, although ovulation weight and final weight approached significance for the early and late groups.

Introduction

The improvement of lamb production and potential income derived from lamb has long been a major concern to the sheep industry. Ovulation rate is generally recognized to set the upper limit of lamb production. Studies (3,6) indicate ovulation rate changes with the season of the year. Some studies (1,2) have suggested that lambing rate shows a positive response to increased nutrition, while other studies have indicated little or no effect of nutrition on lambing rate under certain conditions. Previous studies at this center have failed to show a response to the provision of a protein supplement to fall bred ewes grazed on dry range. The present study was designed to investigate the value of a higher energy level for ewes bred at various times with respect to the breeding season.

Experimental Procedure

During the summer of 1983, 100 aged finewool ewes were purchased from a local market. All ewes were weighed, drenched and sorted into four groups (early and mid-season control or treatment groups). The mid-season groups were held on dry range until the treatments were imposed. Fifty Rambouillet ewes were brought from the Winters Ranch in Brady for the late season feeding study, thus the three groups of ewes were not of the same source. They were also weighed, drenched and sorted into two groups (control and treatment). Control consisted of running on pasture with no feed supplementation for all time periods. Feeding consisted of oat pasture for early season, ad libitum feeding of alkali-treated grain sor-

Table 1. The Effects of flushing on ovulation rate

Season	Number of animals	No. of animals by CL observed			Total Cl.	Ovulation rate	Percent ovulating
		0	1	2 & up			
Early (5-27 to 9-2)							
Control	20	6	10	4	18	.90	.70
Oats	24	2	15	7	29	1.21	.92
Average						1.07	81.80
(31% increase in ovulation)							
Mid (9-13 to 10-21)							
Control	26	-	20	6	32	1.23	100.00
Alkali grain	28	-	16	12	42	1.50	100.00
Average						1.37	100.00
(22% increase)							
Late (11-8 to 12-14)							
Control	24	1	9	14	37	1.54	100.00
Whole grain	22	-	8	14	36	1.64	100.00
Average						1.57	100.00
(6.5% increase)							

ghum for mid-season, and whole grain for late season.

Ovulation rate was determined by observation of corpora lutea (CL) approximately 7 days after estrus detection using the laparoscopic technique. Fertile rams were used for estrus detection in all groups except the late season group in which epididymectomized rams were used. Daily breeding records and weekly body weights were recorded for all sheep. Analysis of variance and Tukey's studentized range test were performed on group body weights. Chi-square analysis and correlations were used to evaluate group ovulation effects, while multiple regression was used to examine the relationship between the various body weights and subsequent ovulation rate.

Results and Discussion

The number of corpora lutea observed, ovulation rate, percent ovulating, and percent increase in ovulation rate for each treatment are shown in Table 1. From chi-square analysis it was found that feeding showed no statistically significant ($P < .05$) increase in ovulation rate or number of corpus luteum within breeding periods. However, early and mid-season feeding did produce a substantial increase (31 percent and 22 percent, respectively) in ovulation rate.

Ewes early in the breeding season which were fed tended to breed earlier and have a higher percent ovulate as well as increased number of eggs shed than ewes run only on native pasture.

Table 2 shows mean body weights at beginning, near ovulation and when the ewe was removed from the study following laparoscopy. Beginning body weights within groups or time period were not significantly

different ($P < .05$) for any of the three time periods examined. Final weights show a similar trend except for the early feeding period in which a significantly ($P < .05$) greater body weight of 119.46 pounds for fed ewes, as compared to 99.85 pounds for the ewes on pasture only, was found. This weight difference can be attributed to decreased pasture quality toward the end of the time involved due to low rainfall for control ewes, while the fed ewes were able to continue grazing mature oats which still had a large portion of the seed in the head.

In Table 3, beginning body weight, weight change, weight nearest ovulation, final weight, and average weight for each period were evaluated for correlation to ovulation rate. None of the five weights was found to be significantly correlated; however, weight nearest ovulation and final weight approach significance for the early and late groups and account for the largest proportion of variability in ovulation rate among the five weights evaluated. Use of multiple regression analysis indicated a significant dependence of ovulation rate on all weights examined with the exception of weight change.

Body weight change for the three periods involved never approached statistical significance, which is similar to results (4) on weight change affecting lamb production. However, these results are contradictory to those suggested by Torrell (7) in which he reported that weight change and lamb production were highly correlated.

The effect of body weight change on ovulation rate needs further statistical investigation which is not available at the time of this writing since there is some difficulty in evaluating non-normally distributed variables against the discrete variable, number of CL observed.

The evidence of this study suggests that a non-significant, although substantial, increase in ovulation rate can be realized when feeding ewes during a breeding season similar to the early and mid-seasons investigated in this study.

Table 2. Mean body weights

Season	No.	Initial weight	Weight near ovulation	Final weight
Early				
Control	20	97.40 ^a	99.80 ^a	99.85 ^a
Oats	24	98.82 ^a	118.88 ^c	119.46 ^b
Difference		1.43	19.08	19.61
Mid				
Control	26	104.35 ^{ab}	106.12 ^{ab}	102.19 ^{ac}
Alkali grain	28	104.21 ^{ab}	104.86 ^{ab}	105.12 ^{ac}
Difference		.14	1.26	2.93
Late				
Control	24	109.63 ^b	113.13 ^{bc}	115.13 ^{bc}
Whole grain	22	109.86 ^b	116.55 ^c	116.87 ^{bc}
Difference		.23	3.42	1.74

Means within column with same superscript are not significantly different ($P < .05$).

Literature Cited

1. Campbell, F.R., J.H. Jones, and W.T. Hardy. 1959. Response of range ewes to flushing. Tex. Agri. Exp. Sta. PR-2111.
2. Darroch, J.G., A.W. Nordskog, and J.L. Van Horn. 1950. The effect of feeding concentrates to range ewes on lamb and wool productivity. J. Anim. Sci. 9:431.

Table 3. Correlation coefficients and variability for ovulation and weight comparisons

Season	Beginning weight	Weight nearest ovulation	Weight change	Average weight (initial & final)	Final weight
Early	.1325	.2794	.2206	.2358	.2802
Mid	.1155	.1466	.0344	.1716	.1919
Late	.2033	.2905	.1778	.2615	.2863

3. Dermody, W.C., W.C. Foote, and C.V. Hulet. 1966. Effects of season of year and progesterone synchronization on ovulation rate. *J. Anim. Sci.* 25:585 (Abstr.).
4. Hulet, C.V., R.L. Blackwell, S.K. Ercanbrack, D.A. Price, and R.D. Humphrey. 1962. Effects of feed and length of flushing period on lamb production in range ewes. *J. Anim. Sci.* 21:505.
5. Shelton, M. and J.T. Morrow. 1965. Effect of season on reproduction in Rambouillet ewes. *J. Anim. Sci.* 24:795.
6. Torrell, D.T., E.D. Hume, and W.C. Weir. 1972. Effect of level of protein and energy during flushing on lambing performance of range ewes. *J. Anim. Sci.* 34:479.

PR-4377

Developing Methods for Gene Transfer in Sheep

B.S. Minhas, J.S. Capchart,
M.J. Bowen, and D.C. Kraemer

Processes of gene transfer, commonly referred to as genetic engineering, offer prospects for dramatic improvement in the efficiency of sheep production. For example, it may be possible to increase feed efficiency, disease resistance, or even product quality by transferring genes from other animals into the sheep cell nucleus where they would be incorporated into the chromosomes and passed on to their offspring. However, extensive research will be required before these prospects can be realized. We have recently started a research project which is designed to develop methods for gene transfer in sheep. To date, we have collected recently fertilized ova (zygotes) from nine donor sheep. We have developed methods for visualizing the pronuclei in the sheep zygote during the process of microinjection of the foreign genes. A viral enzyme (thymidine kinase) gene has been injected into the pronuclei of four sheep zygotes and they have been transferred to the oviduct of a recipient ewe. A pregnancy with a single fetus has been diagnosed in this recipient using an ultrasound scanner. If the pregnancy continues to term, the offspring will be tested to determine whether or not this foreign gene has been incorporated into the genome and whether or not it is functioning. This gene is being used as a model for developing the procedures for gene transfer. After methods are fully developed with this gene, other genes for physiological regulators such as interferon and growth hormone will be studied.

PR-4378

A Modified Technique for the Collection of Uterine Stage Sheep Embryos

J.S. Capchart, M.J. Bowen, J.W. Bassett,
J.M. Shelton, and D.C. Kraemer

The use of embryo transfer as a research tool has enabled scientists throughout the world to acquire a great deal of knowledge about sheep reproductive physiology. The present methods of recovering fertilized sheep ova are very efficient and have routinely resulted in high embryo recovery rates. Unfortunately, after repeated use, these same procedures also result in surgical adhesions of the reproductive tract, which may render the donor ewe sterile. The owners of genetically superior ewes are reluctant to use embryo transfer to upgrade the quality of their flocks. Therefore, this study was conducted to develop a less traumatic and more repeatable embryo recovery procedure.

This recovery method was performed on anesthetized, dorsalrecumbent ewes, tilted head-down at a 45 degree angle. Prior to embryo collection, a laparoscope was inserted into the peritoneal cavity and used to detect ovulation. If ovulation occurred, the tip of each uterine horn was grasped with tissue forceps and exteriorized through a 2.5 cm incision. Once exteriorized, each horn tip was cannulated with an 18-gauge intravenous catheter. Approximately 60 ml of collection fluid was simultaneously infused through each uterine horn using 60 ml syringes. The fluid was forced through the uterus and cervix and into a sterile glass vaginal speculum which was firmly seated against the cervical fornix. This fluid was then collected into a glass recovery dish and the embryos were located using a microscope.

A total of 8 ewes were exposed to 27 collections, 5-7 days after heat, with 17 embryos being recovered. The number of ewes exposed to 6, 5, 3, and 2 separate collection attempts were 1, 1, 4, and 2, respectively. The ratio of total embryos recovered per total number of corpora lutea observed for each of the different recovery attempts was: 7/13 for the first collection, 3/12 for the second collection, 3/5 for the third collection, 1/3 for the fourth collection, 2/2 for the fifth collection, and 1/2 for the sixth collection. Eight of the recovered embryos were passed through a serial dilution procedure to eliminate any bacterial contamination that may have occurred during collection procedures and were then cultured for 24 hours. One ovum showed evidence of bacterial contamination. Two other embryos were placed through serial dilution procedures and then frozen. One was transferred after thawing, resulting in a ewe lamb. Another single embryo was transferred immediately after being subjected to the dilution procedures, resulting in the birth of a ram lamb.

In summary, these data show that embryos can be collected without surgical exposure of the ovaries and oviducts and suggest that subsequent fertility of the donor ewes may be unimpaired through at least five collections.

PR-4379

The Use of Guard Dogs to Reduce or Prevent Predation on Sheep or Goats

M. Shelton and D. Spiller

Summary

Predation remains a major deterrent to efficient sheep and goat production, and the potential for these species is not being fully realized in the state. All approaches need to be explored for dealing with the problem of coyote predation. One approach which is relatively new in this country is the use of guard dogs. Producers in some other parts of the world have had a long history of successfully using guard dogs. In the present study, dogs were raised under controlled conditions with sheep and goats and later placed under test conditions with private flocks. A high degree of protection was obtained when dogs were known to be present with sheep or goats. However, over 50 percent of the dogs failed to work or were lost for a variety of reasons. Private producers report higher success rates. Even with this loss or failure rate, the use of guard dogs offers a great potential for sheep and goat producers in dealing with predation. As an indication of this, the number of dogs, or the number of producers using them, is increasing rapidly over the state. However, this practice, like others, does not offer a complete solution to predator problems and should be considered only as another tool by the industry.

Introduction

Predation remains a major deterrent to sheep and goat production in the state. The use of dogs to protect sheep (and goats) from predation is a very old practice which has only recently received attention in the United States. For instance, some of the breeds of dogs which are being promoted for this purpose have been in existence for hundreds or thousands of years. However, the conditions and manner of their use in the old world is different to that experienced in Texas, and it seems desirable to investigate what contribution they might make under conditions of the South or Southwest.

Perhaps one of the earliest references to the use of guarding dogs was in the notes of Charles Darwin in "The Voyage of the Beagle. Linhart et al. (5) state that dogs historically have been used in certain parts of Europe for their guarding instincts. One of the au-

thors (MS) observed dogs serving this role in the Middle East in the 1950s but failed to realize the potential value in the United States because of the different conditions involved and a lack of awareness of the serious role predation was to become in this country. It is recorded that early Spanish shepherds brought their guard dogs from Europe to the United States in the early settlement of the Southwest (7). These types of dogs, which had been traditionally used for their guarding instincts, were apparently lost in the United States through mongrelization with other dogs. Nondescript or mixed-breed dogs historically have been used by a few sheep and goat producers in the United States and Mexico. Perhaps the most extensive use of these types of dogs has been by the American Indians in the Four Corners Region (1). Limited use has been and continues to be made of mixedbreed guard dogs in South Texas, New Mexico, and Old Mexico. However, in most cases with which the authors are familiar, these mixed-breed dogs are used in conjunction with herders or themselves act as herders, in which the sheep or goats are brought into corrals at night. Under these conditions, the guard dogs may act in the dual role of providing a limited guarding function during the daylight hours and of bringing the animals into corrals at night. It is often stated that from an early age these dogs must grow up with sheep or goats, and in many cases, use them as nursemaids. These are not the traditional practices under which most producers operate and they would not be totally acceptable to range livestock producers. At the present time, it is not known if mixed-breed dogs could be used in a more acceptable manner, so they remain with and guard the flock under free ranging conditions for the 24-hour period. These dogs would need to be large if they are expected to have any deterring effect on predation. It is also generally believed that they should not be of working dog stock, to reduce the likelihood that they would molest the sheep or goats. The guard dog breeds of Europe and the Middle East were also traditionally used in conjunction with herding and/or night confinement, and perhaps this is the reason that guard dogs were so long ignored as offering promise with free ranging flocks of sheep or goats in fenced ranges.

There are a number of breeds of dogs which are considered as guard dogs and other less distinctive types which might serve this role. It is difficult to provide definitive information on the breeds. While it is true that the so-called guard dog breeds do have some advantages such as their size and some inborn guarding instincts, these instincts must be developed in the case of individual animals.

Some of the recognized breeds are:

<i>Breed</i>	<i>Country of Origin</i>
Komondor (Komondoruk)	Hungary
Great Pyrenees	France and Spain
Maremma	Italy
Shar Planinetz	Yugoslavia
Kuvasz	Hungary and Turkey
Anatolian Shepherd (Akbash or Karabash)	Turkey

In addition to the above breeds, unique types of dogs that are serving a guarding function are often found in other areas. Some of the above breeds of dogs show a great deal of similarity, suggesting a common origin in more ancient times or a correlation between form and function as suggested by the Coppingers (2).

Experimental Procedure and Results

Both in research and in practice, guard dogs can be used to provide some protection (4,5) against losses to coyotes. Their value in preventing losses to other types of predation is less clear. One study (4) involved a producer survey in which 72 producers responded, and 77 percent reported reduced losses after using dogs. However, the limited scope of such studies leaves a number of unanswered questions. The most important of these relates to how these dogs work under conditions which are unique to Texas or the Southwest. These unique conditions may be areas of unusually high coyote density, such as much of South Texas, areas with free ranging flocks of sheep or goats in large fenced pastures, and electric fencing, such as that used with intense rotation systems.

Beginning in June 1980, a number of young weaning age dogs of one of the recognized guarding dog breeds were purchased by the Experiment Station or were received as a gift or loan from dog breeders. These were reared on station property with sheep and/or goats. Additional young dogs were obtained from those born within the project. The latter were reared either on station property or with collaborating sheep or goat producers. In general, these young dogs were reared with a small number of young or orphaned lambs or kids. As they grew, they were placed with larger animals and larger numbers of animals in larger areas until they were sufficiently mature to move to test situations. Since the young dogs became available at different times of the year, the exact rearing conditions were not always the same. As the dogs matured and were ready for service, they were placed under test conditions on experiment station property or with flocks of cooperating private producers.

From June 1980 until this activity was terminated in 1984, a total of 27 dogs were produced, and some of these were placed on 15 different properties. Komondor, Great Pyrenees, Anatolian Shepherd, and crosses between these breeds were raised. Results from the use of these dogs were based on producer or rancher observations relating to the incidence of predation when the dogs were present compared to prior periods, adjacent pastures or properties where the dogs were not used. No attempt was made to quantify losses under unprotected conditions.

In all test situations, losses to coyote predation were either prevented or reduced when a dog was known to be present in the pasture with sheep or goats. This protection was not complete or 100 percent, as losses are known to have occurred when dogs were present. In both cases, losses were fewer than might have been expected in the absence of the dog. These observations

provide a strong endorsement for the use of guard dogs in the industry. The increase in their use under field conditions in Texas supports this view, and the industry would be remiss in their duty if they do not consider this alternative as a means of dealing with predation.

Of the 27 dogs which were involved in this study, only 13 or 48 percent remain in use. The time period for observations on individual dogs ranges from one to four years. The loss or failure rate includes dogs which did not work and those which have been lost for one or more reasons. This would be a significant part of the cost of using dogs. A look at the reasons for this failure is shown in outline form below.

No. Dogs	Reason for loss or failure
1	Defective rear legs (destroyed)
1	Died from Parvo virus
2	Killed sheep and were destroyed
1	Shot by neighbor
1	Hung in fence and died
1	Died—unknown cause—thought to have been poisoned
2	Strayed or stolen—one later recovered, but did not work thereafter
4	Did not remain with sheep or goats—removed from study
1	Caught in snare and died

This loss rate may not be unusual. R. Coppinger (3) with the New England Farm Center reported that only approximately one-half the dogs placed in service were still working 2 years later. This would not include those culled before being placed in service. Some individual breeders report a much higher success rate, suggesting that some people may be more successful in rearing and utilizing the dogs or that the success rate may be higher for those dogs that remain on the property where they are raised, in contrast to those which are moved between sites.

Large differences were observed between the breeds involved in this study, but the numbers are too small to defend conclusions which might be drawn from these observations. The crossbred dogs involved appeared to be at least as good as the purebreds.

Guard dogs do have a role in preventing or reducing predation, but like other approaches to this problem, they are not 100 percent effective nor do they constitute a total solution to this problem. If one accepts the premise that guard dogs do have a role to play, the pertinent questions become how, when, or where can they be used to best advantage.

The original goal of this effort was to test dogs under conditions which are somewhat unique to Texas. One of these situations was with free ranging sheep in large pastures in West Texas. This was not accomplished, and thus no information can be provided, but it must be true that dogs would find it much more difficult to work under these extensive conditions. A second proposed test situation was with intense rotation schemes where the animals were concentrated in a smaller area by use of electric fencing. This was only indirectly accomplished. On more than

one occasion, the dogs were used in conjunction with electric fencing, which did serve a useful role of keeping the dogs contained and theoretically would also reduce predator incursion (6). A third test situation was in areas of high coyote density in South Texas. Two test situations were evaluated under these conditions. In one test a single dog was run with a small number of goats in a small trap with limited success. In a second test situation, several dogs are currently being used with approximately 500 goats in brush covered pastures (Figure 1) with generally satisfactory results.

Discussion

In order for a dog to be successful, it must (a) remain in pasture with or near the sheep or patrol the area where they are located; (b) must not harm the animals it protects; and (c) must either by its presence or its action have a deterring effect on predation. Few dogs actually kill predators (especially coyotes), but their presence or behavior reduces predation.

Many dogs molest lambs or even older sheep in a playful manner when young. They may be taught not to do this through discipline, and in most cases they will cease this behavior as they grow older. If a dog persists in molesting or killing sheep, it must be culled and preferably destroyed. Although this is often debated, the authors believe it is important that the dogs be reared from early age (such as weaning) with the type of animals they are expected to guard. Also, they do not need to remain for too long with the same small group of animals. Animals experienced problems in shifting to other populations or locations when they remained with only a few animals during their devel-

opment phase. The dogs need to be well fed to reduce the temptation to feed on their charges. From a nutritional standpoint, some of the dry dog foods on the market are satisfactory; however, some dogs did not eat the dry food. They may need to be provided periodically with some alternative such as meat, canned dog food, or moistened dry food.

Young dogs from the same litter should not be introduced to a flock at the same time since they may be more inclined to play, which interferes with their guarding role, and molest the flock. Pairing a young dog with an older experienced dog seems to work better.

Many problems have been encountered when the guard dogs or neighboring dogs were in estrus so it is recommended that working dogs be neutered. With young males, the producer might do this himself, but with females a substantial veterinary charge would be incurred.

In areas of high coyote density and with large numbers of animals scattered over extensive areas more than one dog is required with each flock. In this study, dogs were not placed on large properties where sheep are located in several pastures.

One of the problems encountered with guard dogs is a tendency to become attached to people and to remain around them or the farmstead. The owner or caretaker should not allow the young dog to follow them away from the flock. It is permissible and possibly desirable that the dogs recognize and accept human companionship, but only in the dog's environment with the flock. If the dog is taught commands, the most important are to come to the owner or



Figure 1. A castrate male dog (Komondor X Great Pyrenees cross) with Angora wethers in South Texas Plains. Note extensive brush cover in background. A great potential exists for goat production in this region if the problem of coyote predation can be solved.

caretaker, stay with the flock, and refrain from harassing the animals.

Another problem which may be encountered is the use of dogs in areas with other, especially lethal, coyote control practices such as the use of toxins (M-44), traps, or snares. On the owner's own property, the dogs can be confined while these practices are in use. However, since dogs do not always remain in the same pasture, a buffer zone needs to be provided. The use of guard dogs works well with some practices such as fencing (including electric fencing) and night confinement.

The dogs appear to work best on small or medium sized properties where the man, dog, area, and flock relationship remains reasonably constant.

Acknowledgement

A number of private producers participated in this effort and their contribution is recognized.

Literature Cited

1. Black, H. L. 1981. Navajo sheep and goat guarding dogs: A new world solution to the coyote problem. *Rangelands* 3:235-237.
2. Coppinger, L. and R. Coppinger. 1982. Livestock guarding dogs that wear sheep's clothing. *Smithsonian* 13:65 (April 1982).
3. Coppinger, R. 1983. Personal communication.
4. Green, J. S. and R. A. Woodruff. 1980. Is predator control going to the dogs? *Rangelands* 2:187.
5. Linhart, S. B., R. T. Sterner, T. C. Carrigan, and D. R. Henne. 1979. Komondor guard dogs reduce sheep losses to coyotes: A preliminary evaluation. *Journal of Range Management* 32:238-241.
6. Shelton, M. 1984. The use of conventional and electric fencing to reduce predation on sheep and goats. *Tex. Agri. Expt. Sta. MP-1556*.
7. Wentworth, E. N. 1948. *America's sheep trails*. pp. 406-407. The Iowa State College Press, Ames, Iowa.

PR-4380

Acute Helenalin Toxicity in Sheep

A.C. Anderson, L.P. Jones, and H.L. Kim

The acute toxic effects of helenalin, a constituent of smallhead sneezeweed (*Helenium microcephalum*), were studied in eight ewes. Helenalin solution, 0.3 percent in physiologic saline, was administered via jugular vein at hourly infusion of 10 mg/kg without anesthesia. The accumulative lethal dose ranged from 30 to 50 mg/kg and mortality occurred within 5 to 29 hours following the initial dose.

The immediate effects of helenalin were lachrymation, salivation, and profuse salivation and nasal discharge continually until the ewes died. Other manifestations of toxicity were labored respiration, clonic convulsions—as early as 1½ hours prior to death, and extreme muscular weakness. Electrocardiographic aberrations indicated helenalin exerted a direct toxic effect on the specialized conduction system of the heart, as well as producing myocardial ischemia, pericardial effusion, and ectopic pacing of the heart.

The post mortem and histopathologic examination revealed numerous hemorrhages on one or more surfaces of the atria and ventricles, as well as myocardial hemorrhages. Grossly, there was an exudate visible along the margin between the atria and ventricles and along the large vessels of the heart. Microscopically, there was some separation of the muscle fibers by a myxomatous bluish fluid and a distinct impression of swelling of the conducting fibers (Purkinje apparatus). Pulmonary edema was also present in all sheep and one of them had some aspirated rumen contents in its bronchioles. There was a well defined acute toxic hepatosis, in all eight sheep, characterized by centrilobular hepatocellular degeneration and intrahepatocellular bile accumulation. The gall bladders had lesions ranging from simple edema throughout all tissue layers to a severe acute necrotizing cholecystitis. There was also an acute toxic tubular nephrosis with tubular epithelial degeneration and dilated glomeruli filled with proteinaceous fluids. No significant gastrointestinal lesions were found in these animals.

PR-4381

Quantitation of Hymenoxon and Related Toxicants in Plant Samples

H. L. Kim and M. C. Calhoun

Hymenoxon is a toxic sesquiterpene lactone isolated from *Hymenoxys odorata* DC (bitterweed) that has continuously caused losses of sheep and goats since the 1920's. The toxicity of hymenoxon in sheep is essentially identical to that of bitterweed; the hymenoxon content appears to determine the toxicity of a bitterweed sample. Efforts have been focused on the estimation of the toxicity of a bitterweed sample by in vitro assays; however, the most reliable method remains expensive feeding trials in sheep.

Two high performance liquid chromatography (HPLC) procedures were developed to quantitate the hymenoxon content of a bitterweed sample. Hymenoxon was extracted into ethyl acetate either directly from a bitterweed sample or from the initial hot water extract of a dried and ground bitterweed sample and analyzed by reversed phase HPLC. The mobile phase composition was 45-60 percent methanol in water and

the elution was monitored at 235 nm. The preliminary results indicate that the hymenoxon content of bitterweed samples varied from 0.2 to 1.4 percent as determined by HPLC compared to that of 1.0-5.0 percent determined by gas chromatography.

A second method utilizes the facile conversion of hymenoxon into two stable dilactones, psilotropin and greenein, which are then readily detected and quantitated by HPLC as described. The majority of the conversion product was psilotropin under the reaction conditions employed. The former method was also applied to the analyses of related toxicants in other plant species such as smallhead sneezeweed (*Helenium microcephalum*), bitter sneezeweed (*Helenium amarum*), and pingue (*Hymenoxys richardsonii*).

PR-4382

Bitterweed Antidote Research

M.C. Calhoun, B.C. Baldwin, Jr.,
S.W. Kuhlmann, and H.L. Kim

Summary

Administration of bitterweed to lambs fed a control diet (10 percent crude protein) produced signs of poisoning, i.e., elevated serum levels of creatinine, urea nitrogen, gamma glutamyl transpeptidase, and glutamic-oxalacetic transaminase. The bitterweed used contained .68 percent hymenoxon (air-dried basis) and was given at a rate of .25 percent of live weight for 5 consecutive days. Pretreatment of lambs, for a minimum of 9 days, with a diet containing 20 percent crude protein, .5 percent sodium sulfate, .5 percent methionine, and 500 IU of vitamin E per pound of feed provided some protection against the toxic effects of bitterweed; whereas, adding .5 percent ethoxyquin hydrochloride to the 20 percent crude protein diet completely protected the lambs in this study.

Introduction

Several plants growing in the range areas of Texas contain highly toxic sesquiterpene lactones (10). One of these, bitterweed (*Hymenoxys odorata*), is generally considered to be the most serious poisonous plant affecting sheep production in Texas. Bitterweed has produced major economic losses in sheep since the early 1920's (16).

The principal toxicant isolated from bitterweed is a sesquiterpene lactone named hymenoxon which possesses an exocyclic methylene moiety (an alkylating center) (9). The acute toxicity of hymenoxon in sheep essentially is identical to that of bitterweed (19). A facile reactivity between a reduced thiol and an exocyclic methylene group of sesquiterpene lactones has been demonstrated in vitro (6), and this same reaction

is assumed to occur in vivo as a toxic mechanism of hymenoxon and related toxicants isolated from many range plants. Numerous efforts have been directed to increase the tissue thiol contents in rodents and sheep as a means of reducing the toxic effects of poisonous sesquiterpene lactones and plants producing such toxicants (3,8,11,12,13,17).

The toxicity of hymenoxon or bitterweed is reduced with administration of a thiol-containing amino acid or tissue thiol inducers in laboratory animals and sheep. For example, the amino acid cysteine protects dogs and sheep from hymenoxon toxicity (3,8,17), and pretreatment with hepatic thiol inducers such as butylated hydroxy anisole or ethoxyquin reduces the toxicity of hymenoxon in mice (11) and bitterweed in sheep (12). However, cysteine is not a likely antidote for bitterweed poisoning in grazing sheep because of its instability (thiol is readily oxidized in the air) and the high cost of this essential amino acid. Dietary supplementation of protein and sodium sulfate have also been shown to reduce the toxicity of bitterweed in sheep (15).

Reported herein is the effect of dietary supplementation of protein, methionine, sodium sulfate, ethoxyquin hydrochloride, and vitamin E (a natural antioxidant) on the toxicity of bitterweed in sheep and the thiol levels in blood, rumen fluid, and tissues (liver and kidney).

Experimental Procedure

Twenty-four, crossbred lambs (Rambouillet x Suffolk) were assigned at random to individual stalls. A preliminary period of 15 days was used to adapt the lambs to their new environment. During the first 12 days of this period the lambs were given *ad libitum* the control diet (Diet 1, Table 1). During the last three days intake of this diet was restricted to 2.2 lb/day.

Following the preliminary period, eight lambs were randomly assigned to each of the following dietary treatments: (1) Diet 1—10 percent crude protein; (2) Diet 2—20 percent crude protein, 0.5 percent methionine, 0.5 percent sodium sulfate and 500 IU vitamin E/lb; and (3) Diet 3—Diet 2 with 0.5 percent ethoxyquin hydrochloride¹ added. The ingredient composition of these diets is given in Table 1. Table 2 contains the composition of the vitamin and mineral premix used in all diets. All lambs were fed 2.2 lb/d for a minimum of 9 days before bitterweed administration was started.

One-half of the lambs (four sheep) on each diet group were given bitterweed (.25 percent of live weight per day for five days) and the other half (4 sheep) served as control. Bitterweed was mixed with approximately 1.5 liters of warm tap water and placed directly into the rumen (via rumen tube) at 0900 hours each day. The hymenoxon content of the bitterweed used was .68 percent, air dry basis (7).

Feed intake was restricted as follows during the time bitterweed was given: day 1—2.2 lb; day 2—1.6 lb; day

¹Ethoxyquin hydrochloride was prepared from Santoquin® (Monsanto Chemical Co.) as described by Kim (14).

Table 1. Percentage ingredient composition of diets

Ingredient	Diet		
	1	2	3
Cottonseed meal	—	32.0	32.0
Sorghum grain, milo	74.5	42.0	41.5
Alfalfa meal, dehydrated	15.0	15.0	15.0
Sugarcane molasses	8.0	8.0	8.0
Dicalcium phosphate	1.4	—	—
Calcium carbonate	.1	.6	.6
Sodium sulfate ^a	—	.5	.5
Methionine ^b	—	.5	.5
Vitamin E ^c	—	.4	.4
Ethoxyquin hydrochloride	—	—	.5
Vitamin and mineral premix ^d	1.0	1.0	1.0

^aSodium sulfate contains 22.6% S and increased the sulfur content of the diet .11%.

^bMethionine contains 21.5% S and increased the sulfur content of the diet .11%.

^cd,1- α -tocopheryl acetate containing 124,998 IU vitamin E/lb. This level increased the vitamin E content of the diet 500 IU/lb.

^dComposition of the vitamin and mineral premix is given in Table 2.

Table 2. Percentage ingredient composition of the vitamin and mineral premix used in the experimental diets

Ingredient	%	Contribution to the complete diet
Sulfur, elemental	10.0	0.1% S
Potassium chloride	19.0	0.1% K
Zinc oxide	.274	22 ppm/Zn
Salt, plain mixing	64.683	0.65% NaCl
Molasses or fat	1.50	—
Vitamin A ^a	.73	993 IU Vitamin A/lb
Vitamin D ₂ ^b	.093	126 IU Vitamin D ₂ /lb
Vitamin E ^c	.72	9 IU Vitamin E/lb
Antibiotic ^d	3.00	15 mg/lb

^aContained 13,607,700 IU of vitamin A (as vitamin A acetate)/lb.

^bContained 13,607,700 IU of vitamin D₂/lb.

^cContained 124,998 IU of vitamin E/lb as d,1- α -tocopheryl acetate.

^dContained 50 grams of oxytetracycline/lb.

3—1.1 lb; day 4—.55 lb and day 5—.55 lb. This was done for all lambs in order to simulate in lambs not given bitterweed the voluntary reduction in feed intake anticipated in those given bitterweed. This approach was used to allow assessment of the effects of bitterweed and the dietary treatments on blood and tissue thiols independent of the effects of level of feed intake.

All feeds fed and feed refusals were weighed daily. Fresh water was provided *ad libitum*. Live weights of lambs were obtained at the beginning of the preliminary period, just prior to starting the bitterweed challenge, and when the lambs were slaughtered on the day following the last bitterweed dose.

Blood samples were collected by venipuncture into vacutainer tubes just before the first bitterweed dose and again at time of slaughter. Serum was used for determinations of urea nitrogen, creatinine, glutamic-

oxalacetic transaminase and gamma glutamyl transpeptidase.

Thiol concentrations in blood, rumen fluid, and tissues (liver and kidney) were determined by the method of Grasseti et al (5).

In the statistical treatment of the data, procedures described by Steel and Torrie (18) for the analysis of variance of a 3x2 factorial were followed. The main effects of diet and bitterweed and the diet x bitterweed interaction were tested for significance.

Results and Discussion

A summary of live weights, feed intakes, and liver and kidney weights are presented in Table 3. Restricting feed intake to 2.2 lb/d during the preliminary period and the stepwise reduction in feed offered during bitterweed administration effectively removed variations in voluntary feed intake. Thus, the effects of diets in response to bitterweed as well as the effects of bitterweed are not influenced by level of feed intake.

Livers of lambs fed the diet containing ethoxyquin hydrochloride were heavier ($P<.01$) than those of lambs receiving the other diets. Enlarged livers have also been observed in rodents following dietary administration of ethoxyquin hydrochloride (13). Bitterweed dosing increased liver weights ($P<.01$), but the response was dependent upon the diet being fed. The percentage increases in liver weights were 19.0, 5.8 and 1.5, respectively, for Diets 1, 2 and 3. The experimental diets and bitterweed administration were without affect on kidney weights.

Blood and rumen fluid thiol levels were not affected by diet or bitterweed (Table 4). These results are different than those obtained previously (1,2). In a previous study, thiol levels increased when the crude protein content of the diet increased from 10 to 20 percent (1). The lack of response to dietary treatments in this study probably is a reflection of the manner in which feed intake was restricted during bitterweed dosing. The reason for no decrease in blood thiol levels when bitterweed was given in this study may be the relatively low hymenoxon content of the bitterweed used.

There was a diet x bitterweed interaction for liver thiols ($P<.10$). The thiol concentration was increased following bitterweed feeding in sheep that received Diet 3. In contrast, bitterweed did not increase thiol concentrations in livers of lambs fed the other diets (Table 4). There was also an interaction between diets and bitterweed for kidney thiols ($P<.10$). In this instance thiols were increased by bitterweed in kidneys of lambs fed Diets 1 and 2, but not in kidneys of lambs given Diet 3. The concentrations of thiols were slightly greater in kidneys of lambs fed Diets 2 and 3, but these differences were not significant.

Values for serum levels of creatinine, urea nitrogen, gamma glutamyl transpeptidase and glutamic-oxalacetic transaminase are given in Table 5. Feed restriction increased serum creatinine levels in lambs not given bitterweed regardless of the diet fed. Bitterweed administration produced an additional increase

Table 3. Live weights, feed intakes and liver and kidney weights of lambs

Criterion	Diet 1		Diet 2		Diet 3	
	No BTW	BTW	No BTW	BTW	No BTW	BTW
Live weight, lb						
Preliminary	84.4	86.2	86.2	85.1	86.9	81.6
Before BTW dosing	85.5	85.8	86.9	82.4	85.8	79.4
After BTW dosing	86.4	85.1	88.4	82.7	84.4	80.0
Feed intake, lb/d						
Preliminary period	2.11	2.08	2.18	2.02	1.95	1.87
Bitterweed dosing						
1st day	2.10	2.06	2.20	2.06	2.12	1.88
2nd day	1.65	1.46	1.65	1.42	1.64	1.56
3rd day	1.10	1.04	1.10	1.10	1.10	1.06
4th day	.55	.47	.55	.55	.55	.55
5th day	.55	.52	.55	.55	.55	.55
Liver weight, lb	1.29	1.53	1.38	1.46	1.55	1.58
Kidney weight, lb	.22	.24	.24	.22	.23	.23

Table 4. Effects of diet and bitterweed (BTW) on thiol concentrations in blood, rumen fluid and tissues of lambs

Criterion	Diet 1		Diet 2		Diet 3		S.D. ^a
	No BTW	BTW	No BTW	BTW	No BTW	BTW	
Whole blood thiols, mg SH/dl ^b	21.9	22.7	23.4	21.8	23.8	22.5	2.8
Extracellular blood thiols, mg SH/dl	1.31	1.21	1.26	1.18	1.21	1.19	.11
Rumen fluid thiols, mg SH/dl ^b	2.59	2.72	2.57	2.99	2.74	2.64	.30
Liver thiols, g SH/g ^c	265	289	264	246	270	364	43
Kidney thiols, g SH/g ^c	91.9	117.7	97.4	122.7	114.9	113.6	13.4

^aStandard deviation.

^bMilligrams of sulfhydryls per deciliter.

^cMicrograms of sulfhydryls per gram of fresh tissue.

Table 5. Effect of diet and bitterweed (BTW) on concentrations of several serum constituents of lambs

Criterion	Diet 1		Diet 2		Diet 3		S.D. ^a
	No BTW	BTW	No BTW	BTW	NO BTW	BTW	
Creatinine, mg/dl ^b							
Initial	1.18	1.18	1.01	1.18	1.01	1.04	.15
Final	1.32	1.73	1.26	1.57	1.19	1.21	.19
Urea nitrogen, mg/dl ^c							
Initial	12.7	13.3	22.1	22.8	22.2	21.9	2.9
Final	21.1	28.6	17.8	30.0	21.4	22.2	5.0
GGTP, IU/l ^d							
Initial	45.1	39.4	35.8	38.7	56.8	47.2	9.1
Final	50.7	127.2	36.9	46.4	50.4	45.1	31.1
SGOT, SFU/ml ^e							
Initial	88.6	73.8	81.4	79.2	66.0	78.2	7.6
Final	90.2	588.1	75.2	168.4	61.7	80.1	170.4

^aStandard deviation.

^bMilligrams of creatinine per deciliter of serum.

^cMilligrams of urea nitrogen per deciliter of serum.

^dInternational units of gamma glutamyl transpeptidase enzyme activity per liter of serum.

^eSerum glutamic-oxalacetic transaminase enzyme activity reported as Sigma-Frankel units per milliliter of serum.

in creatinine, but the response was less in lambs fed Diet 2. Diet 3 (containing ethoxyquin hydrochloride) protected sheep against the bitterweed induced increase in serum creatinine levels.

Lambs fed the 20 percent crude protein diets (Diets 2 and 3) had higher initial serum levels of urea nitrogen. Feed restriction increased urea nitrogen (Diet 1, no bitterweed); as a result, final urea nitrogen values were similar for all dietary treatments when no bitterweed was given. Bitterweed administration increased serum urea nitrogen values in lambs fed Diets 1 and 2, but not in lambs fed Diet 3 (Table 5).

Increases in serum concentrations of creatinine and urea nitrogen are consistently observed in sheep on bitterweed, and the magnitude of the response has been shown to be related to bitterweed dose (4). Since increased serum levels reflect the extent of kidney damage produced by bitterweed (20), the lack of an increase in these constituents in serum of lambs fed Diet 3 suggests ethoxyquin hydrochloride protected the kidneys against the toxic effects of bitterweed. Similar protection was not observed by the addition of protein, methionine, sulfate and vitamin E to Diet 2.

Diets were without effect on the initial serum values of the enzymes gamma glutamyl transpeptidase and glutamic-oxalacetic transaminase. Bitterweed increased levels of both enzymes in lambs fed Diet 1. The addition of protein, methionine, sulfate and vitamin E to Diet 2 completely prevented the increase in gamma glutamyl transpeptidase and partially prevented the rise in glutamic-oxalacetic transaminase levels (Table 5). The addition of .5 percent ethoxyquin hydrochloride to diet 2 completely prevented the bitterweed-induced increases in both enzymes.

These results demonstrate that dietary components, such as those used in Diets 2 and 3, can reduce the toxicity of bitterweed. Additional crude protein, sodium sulfate, methionine and vitamin E provided, in combination, some protection and have the advantage that they can be added to supplements without Food and Drug Administration approval. Although the greatest benefit was obtained when ethoxyquin hydrochloride was added, ethoxyquin hydrochloride is not approved by the Food and Drug Administration for use in sheep feeds. Additional studies are needed to determine the minimum amount of ethoxyquin hydrochloride to use in sheep supplements.

Literature Cited

1. Baldwin, B.C., Jr., and M.C. Calhoun. 1981. The effect of natural protein on bitterweed poisoning in sheep. *Tex. Agri. Expt. Sta. PR-3893*.
2. Calhoun, M.C., B.C. Baldwin, Jr., and C.W. Livingston, Jr. 1978. Reduction in blood thiols in subacute bitterweed toxicity. *Tex. Agri. Expt. Sta. PR-3512*.
3. Calhoun, M.C., B.C. Baldwin, Jr., and C.W. Livingston, Jr. 1979. Effect of abomasal cysteine addition on response to subacute bitterweed (*Hymenoxys odorata*) poisoning. *Tex. Agri. Expt. Sta. PR-3570*.
4. Calhoun, M.C., D.N. Ueckert, C.W. Livingston, Jr., and B.C. Baldwin, Jr. 1981. Effects of bitterweed (*Hymenoxys odorata*) on voluntary feed intake and serum constituents of sheep. *Amer. J. Vet. Res.* 42:1713.
5. Grasseti, D.R., J.F. Murray, Jr., and H.T. Ruan. 1969. The interaction of 6,6'-dithiodinicotinic acid with thiols and with Ehrlich ascites tumor cells. *Biochem. Pharmacol.* 18:603.
6. Hill, D.W. 1976. Analysis of Hymenoxon in Plant Tissue and the Disposition of Hymenoxon in the Rabbit. Ph.D. Dissertation Texas A&M Univ., College Station, Tx.
7. Hill, D.W., H.L. Kim, and B.J. Camp. 1979. Quantitative analysis of hymenoxon in plant tissue. *Agr. Food Chem.* 27:885.
8. Kim, H.L., M. Szabuniewicz, L.D. Rowe, B.J. Camp, J.W. Dollahite, and C.H. Bridges. 1974. ℓ -cysteine, an antagonist to the toxic effects of an α -methylene- γ -lactone isolated from *Hymenoxys odorata* DC (Bitterweed). *Res. Commun. Chem. Pathol. Pharmacol.* 8:381.
9. Kim, H.L., L.D. Rowe, and B.J. Camp. 1975. Hymenoxon, a poisonous sesquiterpene lactone from *Hymenoxys odorata* DC (Bitterweed). *Res. Commun. Chem. Pathol. Pharmacol.* 11:647.
10. Kim, H.L. 1980. Toxicity of sesquiterpene lactones. *Res. Commun. Chem. Pathol. and Pharmacol.* 28:189.
11. Kim, H.L., A.C. Anderson, M.K. Terry, and E.M. Bailey, Jr. 1981. Protective effect of butylated hydroxyanisole on acute hymenoxon and bitterweed poisoning. *Res. Commun. Chem. Pathol. Pharmacol.* 33:365.
12. Kim, H.L., A. C. Anderson, B.W. Herrig, L.P. Jones, and M.C. Calhoun. 1982. Protective effects of antioxidants on bitterweed (*Hymenoxys odorata* DC) toxicity in sheep. *Amer. J. Vet. Res.* 43:1945.
13. Kim, H.L. 1984. Tissue thiol induction in mice and protective effect against pyrrolizidine alkaloids by dietary ethoxyquin and methionine hydroxy analog. *Vet. Hum. Toxicol.* 26:314.
14. Kim, H.L. 1985. Preparation and dietary effects of ethoxyquin hydrochloride. *J. Toxicol. Environ. Health.* 15:663.
15. Post, L.O. and E.M. Bailey, Jr. 1980. The effects of dietary supplements on chronic bitterweed (*Hymenoxys odorata*) poisoning in sheep. *Tex. Agri. Expt. Sta. PR-3698*.
16. Rowe, L.D., J.W. Dollahite, H.L. Kim, and B.J. Camp. 1973. *Hymenoxys odorata* (Bitterweed) poisoning in sheep. *Southwest. Vet.* 26:287.
17. Rowe, L.D., H.L. Kim, and B.J. Camp. 1980. The antagonistic effect of ℓ -cysteine in experimental hymenoxon intoxication in sheep. *Amer. J. Vet. Res.* 41:484.
18. Steel, R.G.D. and J.H. Torrie. 1960. Principles and Procedures of Statistics. McGraw-Hill, New York.

19. Terry, M.K., H.L. Kim, D.E. Corrier, and E.M. Bailey, Jr. 1981. The acute oral toxicity of hymenoxon in sheep. *Res. Commun. Chem. Pathol. Pharmacol.* 31:181.
20. Witzel, D.A., L.P. Jones, and G.W. Ivie. 1977. Pathology of subacute bitterweed (*Hymenoxys odorata*) poisoning in sheep. *Vet. Pathol.* 14:73.

PR-4383

Ovine Caseous Lymphadenitis: Disease Prevalence, Serologic Status, and Ovine Lymphocyte Antigen Type in a Population of Mature Culled Sheep

J. L. Augustine, R. D. Fister,
and H. W. Renshaw

Summary

A population of mature culled sheep (n = 277) was examined for serologic status against *Corynebacterium pseudotuberculosis* using a newly developed bacterial agglutination test, ovine lymphocyte antigens (OLA), using a recently developed OLA typing system and this information was related to the prevalence and distribution of caseous lymphadenitis (CLA) lesions at the time of slaughter. Of the 277 animals examined for serologic status and lymphocyte type, 56 animals (20 percent) had lesions considered typical for CLA and 18 of 56 had the more serious visceral form of the disease. Of the 56 animals with lesions, 48 had antibody titers of 1:1024 or greater (considered diagnostic of ongoing or prior contact with *C. pseudotuberculosis*) and eight had titers of less than 1:1024. Internal (visceral) abscesses were observed in six of the eight animals with lesions, but antibody titers less than 1:1024. There were 45 animals without lesions that had antibody titers of 1:1024 or greater. Collectively, there were 101 animals of 277 (36 percent) that had either or both lesions and antibody titers of 1:1024 or greater. Alternatively, 176 of 277 animals (64 percent) had neither lesions or antibody titers indicating prior exposure to *C. pseudotuberculosis*.

There was an association between the presence of CLA lesions and a specific ovine T-lymphocyte antigen, namely antigenic determinant 214 of Tx5. This antigenic determinant was present in 10 of 18 animals (56 percent) with visceral lesions, 12 of 38 animals (32 percent) with superficial lesions, and collectively in 22 of 56 animals (39 percent) with abscesses. Gene 214 was present in 52 of 277 animals (19 percent) studied. In relationship to the serologic data 19 of 93 animals (20 percent) with antibody titers of 1:1024 or greater carried 214, whereas 33 of 184 animals (18 percent) with titers less than 1:1024 carried this antigenic determinant. There were 11 of 52 animals (21 per-

cent) with gene 214 which had neither lesions nor serologic evidence of prior antigenic exposure to *C. pseudotuberculosis*. The mechanism of association between CLA and antigenic determinant 214 is probably by gene linkage.

Introduction

CLA is an economically important disease of sheep and goats which is caused by *C. pseudotuberculosis* (6,8,11). The disease is characterized by abscessation of peripheral lymph nodes, especially the prescapular and prefemoral lymph nodes in sheep (6,8). In some infected individuals the disease becomes generalized and abscess formation occurs in many internal organs (i.e., bronchial lymph nodes, liver, lung, kidney) (11). The visceral form of CLA has been suggested as a factor involved in development of the thin ewe syndrome (6,11). The disease has been referred to as insidious in nature and tolerated by the animal until it becomes generalized. It has been reported that animals affected with the visceral form of the disease do not cope well with stress and when confronted with secondary microorganisms, the infection often overcomes their anti-infectious defenses, and death results (6).

In the United States, range flocks reportedly develop higher infection rates than do farm flocks, and the frequency of CLA in the western states is reportedly higher (6). Although there are obviously many ecological differences between parts of the country, there are also substantial differences in the genetic composition of the sheep raised in different areas and in several husbandry practices that may influence the transmission of the disease. Much is currently known about CLA, but an area that has not been explored is the potential relationship between susceptibility to the disease and genetic composition of the host. Studies in other animal species have shown that the major histocompatibility complex (MHC) influences the immune capacity of an individual and in some instances determines susceptibility to a disease (2,5,13). Associations between lymphocyte antigen type and specific diseases have been made in a number of diverse conditions including neurological, gastrointestinal, arthropathies, allergies, and dermatologic disorders. The purpose of the present study was to determine if any association between ovine CLA and the ovine MHC could be identified using a recently developed OLA typing system.

Experimental Procedure

Blood was collected from 277 mature culled Finnish Landrace and Rambouillet ewes and the lymphocytes isolated using a previously described density gradient technique. The cells were tissue typed using a modified microcytotoxicity assay. Serum was collected from clotted blood from each animal and analyzed for antibody using a bacterial agglutination test (1). The prevalence and distribution of CLA lesions were determined by postmortem inspection. The statistical associations were calculated as proposed by Wolf (13) and Haldane (5).

Results and Discussion

Lesions considered typical of CLA were observed in 56 animals (20 percent) of the 277 mature culled ewes studied. The disease had progressed to the visceral form in 18 of the 56 cases (32 percent). Antibody titers of 1:1024 or greater were demonstrated in serum samples from 48 of 56 animals (85 percent) with lesions. In eight animals with lesions the serum antibody titers were less than 1:1024 and in six of these eight individuals the abscesses were in visceral organs. There were 45 animals without lesions with antibody titers of 1:1024 or greater. Antibody titers of 1:1024 or greater in the bacterial agglutination test were considered indicative that the individual had ongoing or prior antigenic contact with *C. pseudotuberculosis*. Neither lesions nor antibody titers indicative of antigenic contact with *C. pseudotuberculosis* were found in 176 of 277 animals (64 percent).

The only class I OLA which was found to be significantly associated with CLA was antigenic determinant 214 of antigen Tx5 ($X^2=15.6$ and relative risk of 74536). A high level of association of antigen 214 was found with the visceral form of CLA with 10 of 18 animals (56 percent) with visceral CLA possessing this antigenic determinant on their T-lymphocytes. Antigen 214 was present in 12 of 38 animals (32 percent) with superficial lesions and in 52 of the 277 animals (19 percent) studied. Without the high percentage of 214 positive animals with visceral lesions, the association of this OLA with CLA was only approaching significance. Collectively, these results suggested that antigenic determinant 214 of antigen Tx5 may be a genetic marker for animals which are at risk for the more severe forms of CLA.

There was no apparent association between antigen 214 and the serologic status of the animals. This antigenic determinant was present in 19 of 93 animals (20 percent) with antibody titers of 1:1024 or greater, 33 of 184 animals (18 percent) with titers less than 1:1024. Neither lesions nor serologic evidence of prior antigenic exposure to *C. pseudotuberculosis* was present in 11 of 52 animals (21 percent) with gene 214.

Associations between lymphocyte antigens and disease susceptibility or resistance have been theorized to possibly result from several different phenomena (10). The receptor hypothesis proposed that a MHC molecule may serve as a receptor allowing for virus attachment or penetration and subsequent disease manifestations. At the present time no examples have been recorded to substantiate this hypothesis. The molecular mimicry hypothesis maintains that the host may be unable to mount an immune response to the infectious agent and be susceptible to the disease because of shared antigenic determinants between the pathogen and its host. Evidence supporting this hypothesis is meager since the probability of complete sharing of determinants, which would be needed to induce a tolerant state, is meager. The Ir gene hypothesis suggests that some combinations of antigen and MHC molecules for unknown reasons do not elicit an immune response. Possibly this occurs because the

pathogen(s) responsible for a certain disease controls antigens which in conjunction with a specific MHC determinant, forms a blind spot in the immune response of the host. There is some evidence for this hypothesis since many MHC-associated diseases have or are suspected of having an immunological component. The linked-locus hypothesis maintains that disease involvement occurs not because of the MHC, but because of a locus linked to the MHC. In these instances there is no direct involvement of the immune system in the MHC-associated disease susceptibility. Rather the disease appears to be associated with a specific MHC allele because of a linkage disequilibrium in the gene pool between the locus and the MHC. It is felt that the mechanism of association between CLA and antigenic determinant 214 is probably by gene linkage.

Controversy over the relative importance of humoral and cell-mediated immunity in allowing for recovery from CLA in small ruminants is not resolved (3,4,7,9). Results from studies in laboratory animal model systems such as the mouse, guinea pig, and rabbit have provided some evidence that at least in those species antibody may have considerable protective value (6). Cameron has summarized the evidence suggesting that humoral immunity is protective in small ruminants (3,4). Recent studies suggest that goats develop a pronounced delayed-type hypersensitivity response to certain antigens of *C. pseudotuberculosis* (6). Evidence from this study indicates that the presence of a particular T-cell antigen is linked with the prevalence of CLA and, most importantly, to the severe visceral form of the disease.

Conventional approaches for controlling CLA such as immunizing livestock against *C. pseudotuberculosis* have met with discouraging results (11). Data from this study suggests that future efforts directed at eliminating high risk individuals from a breeding program may be beneficial. Evidence has been presented suggesting that individuals with antigenic determinant 214 show an increased susceptibility to the severe visceral form of CLA.

Literature Cited

1. Augustine, J.L. and H.W. Renshaw. 1984. Humoral immune and delayed-type hypersensitivity responses of goats to *Corynebacterium pseudotuberculosis* antigens. Unpublished observations.
2. Boehm, R.A. 1983. An analysis of ovine lymphocyte antigens. M.S. Thesis. Texas A&M Univ., College Station, TX.
3. Cameron, C.M. 1982. The immunogenicity of *Corynebacterium pseudotuberculosis*. The "Proceedings." 3rd Int. Conf. Goat Prod. Dis. 3:458-468.
4. Cameron, C.M., J.L. Minaar, M.M. Englebrect, and M.R. Purdom. 1970. Immune response of Merino sheep to inactivated *Corynebacterium pseudotuberculosis*. Onderstepoort J. Vet. Res. 37:327-333.
5. Haldane, B. 1948. The number of genotypes

which can be formed with a given number of genes. *J. Genet.* 49:117-131.

6. Hsu, T.-Y. 1983. Caseous lymphadenitis in small ruminants: clinical, pathological, and immunological responses to *Corynebacterium pseudotuberculosis* and to fractions and toxins from the microorganism. Ph.D. Dissertation. Texas A&M Univ., College Station, TX.
7. Irwin, M.R. and H.D. Knight. 1975. Enhanced resistance to *Corynebacterium pseudotuberculosis* infection associated with reduced serum immunoglobulin levels in levamisole treated mice. *Infect. and Immun.* 12:1098-1103.
8. Jensen, R. 1974. Caseous lymphadenitis (pseudotuberculosis). pp.366-369 *In Diseases of Sheep.* Lea & Febiger. Philadelphia, PA.
9. Jolly, R.D. 1965. Experimental infection of convalescent mice with *Corynebacterium ovis*. *New Zealand Vet. J.* 13:148-153.
10. Klein, J. 1983. *Immunology.* Academic Press. Boston, MA. pp. 302-304.

11. Renshaw, H.W., V.P. Graft, and N.L. Gates. 1979. Visceral caseous lymphadenitis in thin ewe syndrome: isolation of *Corynebacterium*, *Staphylococcus*, and *Moraxella* spp. from internal abscesses in emaciated ewes. *Am. J. Vet. Res.* 40:1110-1114.
12. Svejgaard, E. 1975. HL-A and disease association. A survey. *Transplant Review.* 22:3-18.
13. Wolf, B. 1951. On estimating the relation between blood group and disease. *Ann. Hum. Gen.* 19:251-264.

Acknowledgements

This research was supported in part by funds from the Special Grants Program of the United States Department of Agriculture, Science and Education Administration, Cooperative Research (SEA-CR), Research Agreement Numbers 901-15-143, 82-CRSR-2-1075, and 59-22481-0-2-070-0.

PR-4384

Ovine Caseous Lymphadenitis: Lesion Prevalence and Serologic Status of a Population of Mature Culled Sheep

J. L. Augustine, D. H. Warner,
and H. W. Renshaw

Data on prevalence of lesions characteristic of caseous lymphadenitis (CLA) were collected for 660 mature culled sheep (5 to 10 years of age) slaughtered at a West Texas abattoir. Lesions considered characteristic of CLA were obtained from each of the affected animals at slaughter. The lesions were each evaluated by standard aerobic bacteriologic methods for the presence of *Corynebacterium pseudotuberculosis* and other microbial agents. *C. pseudotuberculosis* is the etiologic agent of CLA which is a chronic disease of sheep and goats characterized by suppurative infection of either or both lymph nodes and visceral organs. Additionally blood samples were collected from each slaughtered animal and the blood was allowed to clot, the serum was collected and stored at -20°C until used in a bacterial agglutination test developed in this laboratory for *C. pseudotuberculosis*. Previous studies with experimentally infected goats had shown that a titer of 1:1024 or greater was indicative of ongoing or prior infection with *C. pseudotuberculosis*.

Lesions were found in 100 of the 660 animals (15 percent). Bacterial isolates were recovered from 79 of the 100 lesions (79 percent). *C. pseudotuberculosis* was cultured from 75 to 79 bacteriologically positive lesions (95 percent) and in 20 of the 75 lesions (27 percent) *C. pseudotuberculosis* was recovered in pure

culture (axenic). *Staphylococcus* sp. were recovered from 40 of 75 lesions (53 percent) containing bacterial agents while 14 isolations of *C. pyogenes* (18 percent) and 14 isolations of *Moraxella* sp. (18 percent) were made from the 79 bacteriologically positive lesions. Other bacteria isolated included *Pasteurella* sp. from 5, *Streptococcus* sp. from 2, and *Bacillus* sp. from 2 lesions. An *Enterobacter* sp. and *Shigella* sp. were each recovered from 1 lesion.

Results of the serodiagnostic test revealed that 158 of the 660 sheep were seropositive (24 percent). This included 84 animals with lesions considered characteristic of CLA and 58 animals without lesions. Additionally there were 5 animals with *C. pseudotuberculosis* positive lesions and 11 animals with *C. Pseudotuberculosis* negative lesions which did not have titers of 1:1024 in the bacterial agglutination test. CLA is in many instances a cyclic disease where lesions appear, enlarge, rupture with release of purulent material, regress, appear to heal, and then after a period of time reappear. Thus, it is not unreasonable that we should observe a few individual animals with lesions and low antibody levels and alternatively some animals with no apparent lesions but high antibody levels. Collectively, these results suggest that the recently developed bacterial agglutination test may be a useful test for detection of ongoing or prior infection with *C. pseudotuberculosis* in sheep as well as goats. Such an immunodiagnostic test should prove useful in further studies of this economically important small ruminant disease.

Acknowledgements

This research was supported in part by funds from the Special Grants program of the United States Department of Agriculture, Science and Education Administration, Cooperative Research (SEA-CR), Research Agreement Numbers 901-15-143 and 82-CRSR-2-1075.

A Survey of the Selenium Status of Sheep on the Edwards Plateau of West Texas

S.R. Sappington, M.C. Calhoun,
B.C. Baldwin, Jr., and S.W. Kuhlmann

Selenium is an essential mineral which is required in trace amounts in the diets of sheep. Dietary levels of .1 to .2 ppm are considered adequate for sheep of all ages. The most commonly noticed problem in selenium deficient sheep is degeneration of the heart and skeletal muscles (white muscle disease) in young lambs. Although forages and grains grown in Texas are generally considered adequate in selenium content, occasional reports of white muscle disease in lambs prompted an assessment of the selenium status of sheep on the Edwards Plateau. This was accomplished by measuring glutathione peroxidase enzyme activity in the blood of ewes and lambs from four ranches. The ranches from which samples were collected and the sampling dates were: (1) Turner Ranch, Water Valley, 5-8-85; (2) Texas Range Station, Barnhart, 5-13-85; (3) Texas A&M Research Station, Sonora, 6-6-85 and (4) Winters Ranch, Brady, 6-7-85. Glutathione peroxidase is a selenium containing enzyme which is present in the tissues and blood of animals. The level of this enzyme in the body has been used as an indicator of the adequacy of selenium in the diets of sheep. A response to selenium supplementation is generally not observed in lambs unless blood levels of glutathione peroxidase are less than 30 units per gram of hemoglobin; whereas, sheep receiving adequate selenium exhibit activities greater than 500 units per gram of hemoglobin. The values obtained in this survey are summarized in Table 1.

The sheep on these ranches had not received a mineral supplement containing selenium; therefore, the forage they were consuming probably contained adequate amounts of selenium. Since a deficiency of either selenium or vitamin E will produce white muscle disease in lambs, occasional problems with white muscle disease may be due to low levels of vitamin E.

Table 1. Glutathione peroxidase activity of whole blood collected from sheep at four locations

Item	Ranch location			
	Water valley	Barnhart	Sonora	Brady
	Enzyme units/g hemoglobin ^a			
Ewes	533 (13) ^b	430 (10)	534 (10)	466 (10)
Lambs	520 (15)	491 (10)	535 (10)	412 (10)

^aEnzyme activity units are expressed as μ moles β -NADPH oxidized per minute at 25°C (Paynter, Aust. J. Agric. Res. 30:695. 1979).

^bNumber of samples.

Acknowledgement

The cooperation of Dr. Percy Turner is greatly appreciated.

PR-4386

Dexamethasone-Induced Suppression of Adrenocorticotropin (ACTH) and Cortisol Secretion in Rams

K. A. Wagner, P. E. Juniewicz,
and T. H. Welsh, Jr.

Animal productivity would be enhanced if the deleterious effects of stress on reproduction and growth were minimized. In general, the hypothalamic portion of the brain produces the peptide hormone corticotropin releasing factor (CRF) which is released during stress. CRF stimulates the release of the pituitary hormone adrenocorticotropin (ACTH) which, in turn, rapidly activates cortisol secretion by the adrenal cortex. In contrast to these positive or stimulatory signals, a high level of cortisol exerts a suppressive or negative feedback effect on secretion of CRF and ACTH. In this way the endocrine glands of the hypothalamic-pituitary-adrenal axis rapidly interact via blood-borne chemical communicators (e.g., hormones such as CRF, ACTH and cortisol) to coordinate an animal's response to environmental stress. The current study with sheep is part of a larger project designed to elucidate the mechanisms involved in mediating the hormonal response of livestock to stress.

Sixteen Finn-Dorset rams (211 days of age and 73 lb body weight) were treated with either 5 mg dexamethasone (a potent synthetic corticosteroid), isotonic saline, or propylene glycol (the vehicle for dexamethasone). Blood samples were taken every 15 minutes beginning 3 hours prior to treatment and continuing 6 hours thereafter. Both treatment administration and blood sampling were via indwelling jugular cannulas. The serum concentrations of ACTH and cortisol were determined using radioimmunoassay (RIA) procedures. The propylene glycol and saline-treated rams were combined into a single control group as there was no significant difference between these groups in terms of blood levels of ACTH and cortisol.

During the 3-hour period prior to treatment, peaks in concentration of ACTH occurred either immediately before or coincided with the occurrence of cortisol peaks within individual rams. This is consistent with the concept that ACTH exerts a positive, stimulatory effect upon the adrenal cortex. Relative to the time of treatment, the average concentrations of serum ACTH and cortisol in the control rams were

unchanged after treatment. However, the dexamethasone-treated rams exhibited a decrease in secretion of both ACTH and cortisol during the 6-hour time period after treatment.

The areas under the hormone profile curves were used to compare the amount of hormone present in the blood over specific periods of time. For the 3 hours prior to treatment the areas beneath the ACTH and cortisol curves were correlated ($r=.64$, $P<.05$) for all 16 rams in the study. For the entire 9-hour sampling period for the 8 control rams, the areas beneath the ACTH and cortisol curves were correlated ($r=.83$, $P<.05$). These findings indicate that the amount of ACTH secretion is positively associated with the amount of cortisol secreted by individual rams. The area under the ACTH and cortisol curves increased 13 and 16 percent, respectively, for the 3-hour period following injection in the control rams, while the area under these curves during the same period decreased 32 and 36 percent, respectively, in the dexamethasone-treated rams. The decreased area beneath the ACTH and cortisol hormone profiles reflects the marked decrease in the secretion of ACTH and cortisol.

These data provide insight regarding a positive temporal association between secretion of ACTH and cortisol. Furthermore, the temporal aspects of the negative feedback effects of corticosteroids on the secretion of ACTH was demonstrated by the data derived from the dexamethasone-treated rams.

Results of this initial study will assist in further experimentation to understand how components of the hypothalamic-pituitary-adrenal system intercommunicate during stress. This information is essential in order to minimize the deleterious effects of managerial and environmental stress upon reproduction, growth, and overall health and productivity of live-stock.

PR-4387

Effects of Season of Birth, Dietary Energy Level, and Lasalocid on the Performance of Sheep

S.W. Kuhlmann, M.C. Calhoun,
G.R. Engdahl, and C.S. McCown

Summary

Forty-eight fall born (119 ± 12 lb) and 48 spring born (89 ± 16 lb) Rambouillet ram lambs were used in a $2 \times 3 \times 2$ factorial experiment (completely random design with two replications) to examine the effects of season of birth, dietary levels of digestible energy (1.18, 1.32 and 1.45 Mcal/lb, as fed basis) and lasalocid (0 and 25 g/ton, as fed basis) on live weight gain, feed

intake, feed requirements for gain, and fecal coccidial oocyst numbers. The diets were based on sorghum grain (milo), peanut hulls, and cottonseed meal. The feeding period was 56 days. In addition, 36 yearling, castrated, male sheep (112 ± 1 lb) were used to determine the effects of lasalocid on digestibility of diets. Overall, spring born lambs had higher live weight gains (.688 vs .562 lb/day) and decreased feed requirements for gain (6.31 vs 7.49) than fall born lambs ($P<.01$). Feed intake was not affected by season of birth. Increasing digestible energy increased live weight gain ($P<.10$), decreased feed intake ($P<.01$), and decreased feed requirements for gain ($P<.01$). Overall, lasalocid was without effect on live weight gain but decreased feed intake 5.1 percent ($P<.05$). Lasalocid decreased feed requirements for live weight gain 5.5 percent but the difference was not statistically significant. Interactions existed between digestible energy and lasalocid for live weight gain ($P<.05$) and feed intake ($P<.01$). Live weight gains increased as the digestible energy content of the diet increased when lasalocid was present in the diet, but not when lasalocid was absent. In contrast, feed intake decreased with increasing digestible energy without lasalocid, but not with lasalocid in the diet. Apparent digestibilities of dry matter, organic matter and neutral detergent fiber were not affected by lasalocid; whereas, crude protein was increased (70.9 vs 67.8, $P<.01$) and acid detergent fiber was decreased (21.9 vs 25.7, $P<.05$). Fecal oocyst counts were decreased by lasalocid at 28 ($P<.05$) and 56 days ($P<.10$).

Introduction

Lasalocid¹ (Bovatec®) is an antibiotic feed additive which belongs to a class of compounds called ionophores. The term ionophore refers to the compound's capacity to aid the passage of cations across lipid membranes of cells (2,7). Lasalocid has been approved for use with sheep as a coccidiostat at levels of 20 to 30 g/ton. In addition to controlling coccidiosis, lasalocid has a positive effect on performance of growing lambs (5,6,9,10). However, in a previous study the response to lasalocid was dependent upon the energy concentration in the diet (6). The improvement in performance was greater in a diet containing 1.2 Mcal digestible energy per pound than in one containing 1.4 Mcal. The purpose of this research was to provide additional information on the nature of the interaction between lasalocid and the energy concentration of the diet.

Experimental Procedure

Forty-eight fall born and 48 spring born Rambouillet lambs were used in a $2 \times 3 \times 2$ factorial experiment (completely random design with two replicates) to determine the effects of season of birth (fall and spring born), dietary digestible energy (1.18, 1.32, and 1.45 Mcal/lb), and lasalocid (0 and 25 g/t) on the perform-

¹Lasalocid - Bovatec®, Roche Chemical Division, Hoffmann LaRoche, Inc., Bovatec 68, containing 68 g lasalocid sodium per pound of premix.

ance of ram lambs. Initial live weights for fall and spring born lambs were 119 ± 12 and 89 ± 16 lb, respectively. Lambs were vaccinated for enterotoxemia (1 ml *Clostridium perfringens* Type C₂ and D toxoid/animal) and drenched with an anthelmintic (Tramisol®).²

Each lamb was randomly assigned to one of 24 pens (4 lambs/pen; 12 pens each of fall and spring lambs) and fed a low energy (1.04 Mcal DE/lb) starter ration. Feed was increased .5 lb/d until ad libitum feeding was achieved. Energy levels were stepwise increased until all lambs were adapted to the intermediate energy level (1.32 Mcal DE/lb) (Table 1).

At the start of the 56-day feeding period each pen was randomly assigned to 1 of 6 treatments and started on its respective diet. Feed was fed daily (ad libitum) and lambs were weighed (unshrunk) on days 0, 28, and 56 of the trial. A fecal sample was obtained from one animal/pen on the days they were weighed and used for determination of coccidial oocyst numbers (3). The analysis of variance for a completely random 2x3x2 factorial experiment was used in the statistical treatment of the data (8).

Thirty-six yearling, crossbred, wethers (112 ± 1 lb) were randomly assigned to metabolism stalls to determine the digestibility of the six experimental ratios used in the first trial. A preliminary period of 16 days was used to allow animals to adjust to the stalls and feeds. Feed intake was restricted to 3.3 lb/day and the preliminary period was followed by a 7-day collection period. Total fecal output/wether was recorded each morning, and a 10 percent subsample was retained for subsequent analysis. Subsamples were dried at 140°F in a forced-draft oven and then allowed to equilibrate with air moisture to determine partial dry matter. Feed samples were taken each day during the collection period. Dry matter organic matter, crude protein, acid-detergent fiber, neutral-detergent fiber, and ash were determined for all feed and fecal samples (1,4).

Results and Discussion

Fecal coccidial oocyst numbers were initially higher in the lambs which subsequently received lasalocid (Table 2). Oocyst numbers decreased in all lambs as the experiment progressed, but the decrease was more dramatic in lambs fed diets containing lasalocid. Coccidiosis was not a problem during the experiment and responses to lasalocid were not believed to be dependent upon the value of lasalocid as a coccidiostat.

The spring born lambs gained 22.4 percent ($P < .01$) faster and required 15.8 percent ($P < .01$) less feed per pound of gain than the lambs born during the fall and which were started on the experiment at a heavier weight (Table 3). Feed intake was not affected by season of birth.

Increasing the digestible energy content of the diet increased rate of live weight gain ($P < .10$), decreased feed intake ($P < .01$) and reduced the amount of feed

²Tramisol®—American Cyanamid Co., .25 g of levamisole hydrochloride was given to each lamb in 20 ml of water using an automatic drench gun.

Table 1. Ingredient composition of experimental diets

Ingredients	Digestible energy (Mcal/lb)		
	1.18	1.32	1.45
	%		
Sorghum grain, milo	52.9	64.4	74.3
Peanut hulls	26.3	16.0	7.0
Cottonseed meal	12.9	11.7	10.8
Molasses, sugarcane	5.0	5.0	5.0
Calcium carbonate	1.4	1.4	1.4
Mineral and vitamin premix ^a	1.5	1.5	1.5

^aThe mineral and vitamin premix contained 48.2% calcium carbonate, 17.2% ammonium chloride, 29.7% plain salt (NaCl), 3.4% sulfur, .17% zinc oxide, .25% manganese sulfate, .25% vitamin A acetate (13.6×10^6 IU/lb), .005% vitamin D₂ (90.7×10^6 IU/lb), and .64% d,l- α -tocopherol acetate (12.5×10^4 IU/lb).

Table 2. Effects of dietary lasalocid (25 g/ton) on fecal coccidial oocyst numbers

Treatment	Number sheep	Coccidial oocyst numbers/g of feces		
		Sampling time (days)		
		0	28	56
No lasalocid	12	4,908	2,200	1,450
Lasalocid	12	17,458	433	292
Statistical effects ^a	—	NS	P < .05	P < .10

^aNS=No significant difference.

required per pound of live weight gain ($P < .01$) (Table 3). Lambs fed the diets containing 1.45 Mcal digestible energy per pound of feed gained 8.4 percent faster on 19.5 percent less feed than ram lambs fed the lowest energy diet (1.18 Mcal DE/lb). These results are consistent with expected responses to increasing the energy level in the diet and explain why high grain diets are widely used for feeding growing-finishing lambs.

Averaged across all other treatments, lasalocid was without effect on live weight gain (Table 3). However, there was a significant interaction ($P < .05$) between lasalocid and the energy concentration of the diet. The nature of this interaction is shown in Figure 1. Lasalocid decreased live weight gains when added to the diet containing 1.18 Mcal DE/lb but increased gains of lambs when added to the diet containing 1.45 Mcal DE/lb. These results are different than those obtained in a previous study in which live weight gain was depressed when lasalocid was added to a higher energy diet but was increased when added to a lower energy diet (6). Several other studies have all reported a slight positive effect of lasalocid on live weight gains in lambs fed diets which covered a range of concentrate:roughage ratios (5,9,10).

Feed intake was depressed when lasalocid was added to the diets containing 1.18 and 1.32 Mcal DE/lb, but not when added to the 1.45 Mcal DE/lb diet. This interaction between lasalocid and digestible energy concentration in the diet is shown in Figure 1.

Table 3. Effect of season of birth (SB), dietary digestible energy (DE) and lasalocid (L) levels on performance of ram lambs

Criterion	Season of birth ^a		SB ^b Effect	DE Mcal/lb ^a			DE ^b Effect	L g/ton ^a		L ^b Effect
	Fall	Spring		1.18	1.32	1.45		0	25	
Liveweight gain, lb/day	.562	.688	P<.01	.606	.611	.657	P<.10	.624	.626	NS
Feed intake, lb/day	4.21	4.34	NS	4.50	4.28	3.92	P<.01	4.34	4.12	P<.05
Feed/gain, lb/lb	7.49	6.31	P<.01	7.42	7.00	5.97	P<.01	6.96	6.58	NS

^aValues for season of birth, digestible energy and lasalocid levels, in this table, are averages across all other treatments.

^bNS=No significant difference.

Table 4. Effects of dietary levels of digestible energy (DE) and lasalocid (L) on digestibility coefficients

Criterion	Digestible energy			DE Effects ^a	Lasalocid		L Effects ^a
	Mcal/lb				g/ton		
	1.18	1.32	1.45		0	25	
Dry matter intake, lb/d	2.60	2.51	2.58	NS	2.73	2.38	P<.05
<u>Apparent digestibility coefficients</u>							
Dry matter, %	68.6	73.5	79.9	P<.01	73.6	74.4	NS
Organic matter, %	69.7	75.0	81.2	P<.01	74.9	75.7	NS
Crude protein, %	67.3	69.3	71.5	P<.05	67.8	70.9	P<.01
Acid detergent fiber, %	19.0	21.4	31.0	P<.01	25.7	21.9	P<.05
Neutral detergent fiber, %	21.5	24.9	30.7	P<.01	26.9	24.5	NS

^aNS=No significant difference.

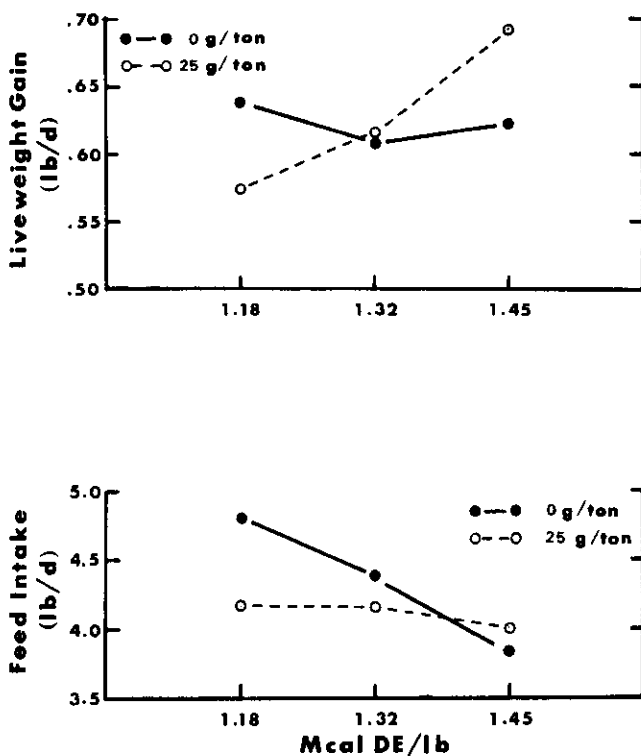

Figure 1. Digestible energy (DE) X lasalocid interactions for liveweight gain and feed intake.

Averaged across all other treatments lasalocid decreased feed requirements for live weight gain by 5.4 percent, however this difference was not significant. There was not an interaction between lasalocid and digestible energy for feed efficiency (feed/gain).

Digestible energy and lasalocid effects on the digestibility of the experimental rations are listed in Table 4. Increasing digestible energy increased the percent digestibility of dry matter, organic matter, acid and neutral detergent fiber (P<.01) and crude protein (P<.05). Addition of lasalocid to the diet increased crude protein digestibility (P<.01) and decreased acid detergent fiber digestibility (P<.05), but was without effect on digestibility of dry matter, organic matter and neutral detergent fiber.

Literature Cited

1. AOAC. 1970. Official methods of analysis (11th Ed.). Association of Official Analytical Chemists, Washington, D.C.
2. Bergen, W.G. and D.B. Bates. 1984. Ionophores: their effect on production efficiency and mode of action. J. Anim. Sci. 58:1465.
3. Dunn, A.M. 1978. Veterinary helminthology (2nd Ed.). William Heinemann Medical Books, Ltd., London.
4. Harris, L.E. 1970. Nutrition research techniques for domestic and wild animals. Vol. I. Lorin E. Harris, Logan, Utah.
5. Horton, G.M.J. and P.H.G. Stockdale. 1981. Lasalocid and monensin in finishing diets for early

weaned lambs with naturally occurring coccidiosis. Amer. J. Vet. Res. 42:433.

6. Mankusa, M.M., M.C. Calhoun, G.R. Engdahl, S.W. Kuhlmann, and C.S. McCown. 1986. Effects of lasalocid, energy and protein on performance of lambs. Tex. Agr. Exp. Sta. PR-4393.
7. Ouens, F.N. 1980. Ionophore effect on utilization and metabolism of nutrients-ruminants. p.17 *In* Proc. 1980 Georgia Nutr. Conf., Univ. of Georgia, Athens.
8. Shetaewi, M. and T.T. Ross. 1985. Effect of lasalocid on growth, feed intake and efficiency of feed utilization of lambs. Proc. Western Sect. Amer. Soc. Anim. Sci. 36:143.
9. Steel, R.G.D. and J.H. Torrie. 1980. Principles and procedures of statistics (2nd Ed.). McGraw-Hill Book Co., New York.
10. Thomas, V.M. and J.J. Dahmen. 1985. Effect of roughage to concentrate ratio and lasalocid on lamb performance and carcass characteristics. Proc. Western Sect. Amer. Soc. Anim. Sci. 36:480.

PR-4388

Evaluation of Fourwing Saltbush as an Alternative Forage for Goats

J.E. Huston and D.N. Ueckert

Fourwing saltbush (*Atriplex canescens*) is a widely distributed, native shrub in West Texas with characteristics for use in revegetating disturbed or depleted rangelands. Saltbush is a drought-tolerant evergreen and would be available during the two most critical circumstances for grazing animals in West Texas, i.e. drought and severe winter dormancy periods. Preliminary studies indicate that the species can be established on marginal rangeland and can produce abundant foliage under limited moisture conditions. However, grazing studies with young Angora goats suggest that saltbush is of lower nutritional value than would be expected based on its chemical composition (16 percent crude protein; 60 percent in vitro digestible dry matter). One possible explanation is that the protein in the saltbush is bound and not readily available at the ruminal level.

A digestion trial was conducted to measure intake, digestion and nitrogen balance in Angora goats fed fresh saltbush leaves with or without a protein supplement. Four goats were fed 300 g/day (air dry) of a supplement containing 22 percent sorghum grain, 10 percent dehydrated alfalfa, 65 percent cottonseed meal, 2 percent molasses, and 1 percent salt (approximately 32 percent crude protein). Four other goats were not fed the concentrate. All 8 goats were fed ad

libitum freshly cut new growth (leaves and tender twigs) from locally grown saltbush plants.

The goats that received no supplement consumed 28.7 g/kg live wt.^{.75} (dry matter basis). Those fed the supplement consumed 32.6 g/kg live wt.^{.75}, a 13.6 percent greater intake of saltbush. With the added intake of the supplement, goats consumed 80 percent more dry matter and 84 percent more digestible dry matter compared with the goats consuming saltbush only. These data suggest that intake of saltbush may be limited by a shortage of digestible protein and can be stimulated by feeding of a protein supplement. Analyses for digestibility and nitrogen balance are not completed.

The high potential of fourwing saltbush for use in West Texas justifies continued efforts to clarify the factors and mechanisms that affect its nutritional value for grazing animals.

PR-4389

Effect of Protein Supplementation on Ewe Performance, Forage Intake, Lamb Survival and Growth

L.H. Ripley and J.E. Huston

One hundred and eighty grade Rambouillet ewes were utilized in a study to examine the effect of protein supplementation on ewe performance, forage intake, lamb survival and lamb growth. Ninety ewes were maintained in unimproved pastures, and 90 were maintained in a drylot with sorghum hay as the sole roughage source. Each group of 90 ewes was divided into 4 protein subgroups. Nine ewes in each, the pasture and the drylot, were treated as controls and received no supplement during the study. The remaining 81 ewes in each group were divided into 3 groups of 27 ewes each and individually fed one of 3 protein supplements in amounts based on each ewe's actual body weight at the start of the study.

Supplements were formulated assuming that forage would supply an average of half the ewes' requirements and that the supplement would supply the amount of protein necessary to bring the ewes' crude protein (CP) intake up to 133, 100, or 67 percent of NRC requirements. The supplements were approximately 35, 22, and 8 percent CP and were nearly equal in digestible energy content.

In addition, each group of 27 ewes was subdivided into groups of 9 ewes. The first group went on feed at the first hard frost, the second group went on feed 6 weeks before lambing and the third group started on feed immediately after lambing. All supplemented ewes remained on feed until 6 weeks after lambing.

Feed allowances were adjusted so that regardless of when a ewe went on feed, all ewes within a protein group (e.g., 133 percent NRC) received approximately the same amount of feed during the study.

Measurements taken included: 1) forage intake during mid- and late pregnancy and lactation; 2) blood levels of glucose and ketones during the last week of pregnancy; 3) fleece measurements: fleece weight, percent clean yield, staple length and fiber diameter; 4) milk production; 5) lamb birth weights; and 6) lamb average daily gain.

PR-4390

Evaluation of the Potential for Chemical Castration of Angora Males

P. Thompson and M. Shelton

Summary

During 1984 and 1985, attempts were made to evaluate the potential of chemical castration as a means of non-surgical castration of yearling Angora males. Two studies, involving 113 yearling males, were conducted in which chemical castration was compared with alternative methods. The commercial product known as "Chem-Cast" as well as lactic acid, the active ingredient of "Chem-Cast," were tested. In general, chemical castration did not appear to work satisfactorily with the procedures employed in this test. The product is approved for use with cattle with the recommendation that they be treated early in life (100-150 lb). At this size or age, the testicular development of young calves would be minimal. By contrast, yearling Angora males have relatively well developed testes. The ratio of testicle weight to body weight is several multiples higher for the goats, with the result that chemical castration is less workable.

Introduction

Angora mutton (wether) goats are a major source of the mohair production in Texas. Typically these animals are handled as intact males until a year of age before castration. During this period, the males are given time to grow and develop as much as possible, resulting in somewhat larger size and more horn development than those castrated early in life. The two most common means of castration for these yearling animals have been the use of the burdizzo or the use of a knife. Both of these methods present some potential problems and postsurgical complications. The use of a knife is a complete method of castration, but is bloody and lends itself to infection and the potential of fly infestations. Pinching of the testicular cord with burdizzos is sometimes not a complete means of castration, and if care is not taken, swelling

and necrosis may also cause problems. So the potential for a sterile, non-surgical, and effective means of castrating Angora males is of interest.

Experimental Procedure

In 1984 and 1985, two separate experiments were conducted with 113 yearling Angora billies to compare the effectiveness of an injectable castrating agent to the more conventional methods of burdizzo or knife castration. These animals were assembled and monitored by Experiment Station personnel on the Winters-Wall Ranch lease at Brady, Texas. Each year the experimental animals were assigned to five treatment groups. In 1984, the experimental animals were grazed on range composed mostly of shinoak. In 1985, oat pasture was available for use during the first 2 months of the experimental period. The castration agent, "Chem-Cast," was administered as per label instructions for cattle at the rate of 0.5 cc and 1.0 cc per testicle in 1984. In 1985, the "Chem-Cast" dosage was increased to 2.0 cc and a treatment with the same dosage of lactic acid (the active ingredient in "Chem-Cast") was used. Each year, intact males were maintained as a control group. All animals were weighed periodically, and testicle circumference measurements were made of intact, burdizzo and injected males. For obvious reasons, it was not possible to measure those which had been surgically castrated.

Results and Discussion

Figure 1 represents the changes in testicular size (circumference) as measured with a metal tape for each year. The data indicates that each of the three non-surgical methods of castration produces a large amount of swelling after treatment. Using "Chem-Cast" or lactic acid at any rate failed to bring about the reduction in testicle mass as did pinching with burdizzos. No failures were noted from castration with the burdizzo, but this does occur sometimes in commercial practices. It should be noted that "Chem-Cast" is recommended for use on calves weighing 100 to 150 lb, very young, sexually immature animal with testicles less than half the size of a properly grown out yearling Angora billy. Some animals in both injection groups in 1985 were seen to be rutting prior to and after the termination of the experiment.

Table 1 shows the animal weight changes during the test period. None of the non-surgical methods of castration showed any harmful side effects to treatment. All three groups gained more weight than those castrated by knife, thus indicating the interest in finding an alternative method. No death losses were observed which were attributed to any of the treatments. After the experiment was terminated, the chemically treated animals were subsequently castrated by knife. It might be expected that if the animals were treated early in life, the chemical castration would be effective. This was not attempted in the present experiment. However, castration at a very early age would not accomplish the goals for which late castration is practiced with Angoras.

A Reoccurrence of the "Silky" Mutant in Sheep

M. Shelton, R.M. Lewis, and J.F. Edwards

Summary

This report calls attention to an abnormal type of fleece which appears to have resulted from a genetic mutation which appears to be the same as that in an animal described earlier as a "silky." This repeated occurrence suggests that the condition represents a mutation which may occur from time to time in sheep and be inherited as a dominant, which would prevent it from remaining unobserved in the flock.

Introduction

Some traits apparently spontaneously occur or reoccur as mutants in livestock species. One such trait which might fall in this category is the dominant gene for the absence of horns. This condition allegedly has occurred in essentially all horned species of domestic livestock (cattle, sheep, and goats) and in most of the breeds. It is not known, at least to the writers, if this mutation has occurred in wild populations of ungulates. However, under these conditions, the hornless gene might not persist in a competitive mating situation. Likewise, the condition known as chondrotophy or chondroplastic dwarfism has occurred in a number of species and breeds, suggesting a high mutation rate for this condition. Since the dwarf condition is inherited in a recessive manner, there is an alternative potential explanation for within species reoccurrence of this trait but not across species.

This report calls attention to another condition which appears to occur from time to time in sheep. Warwick, et al. (3) described a condition which they called 'silky' and reported that it acted as a simple dominant. When first observed, the animal was thought to be a sheep x goat hybrid, and referred to as a "geet." This was not the case. The term "silky" was derived from the animal's glossy appearance and not the wool produced by these animals. It was stated that they also lacked vigor. The original mutant was observed around 1930 in a flock of Delaine Merino sheep.

Experimental Procedure

In 1980, a rancher called to the attention of one of the authors an abnormal animal which he hypothesized might be a hybrid. The animal was a female born in a flock of Rambouillet sheep. There was no known connection between this flock and the one in which the originally reported "silky" occurred. In fact, it was in a different breed, although the two (Rambouillet and Delaine Merino) are both finewool types. This animal was brought to the station and mated to

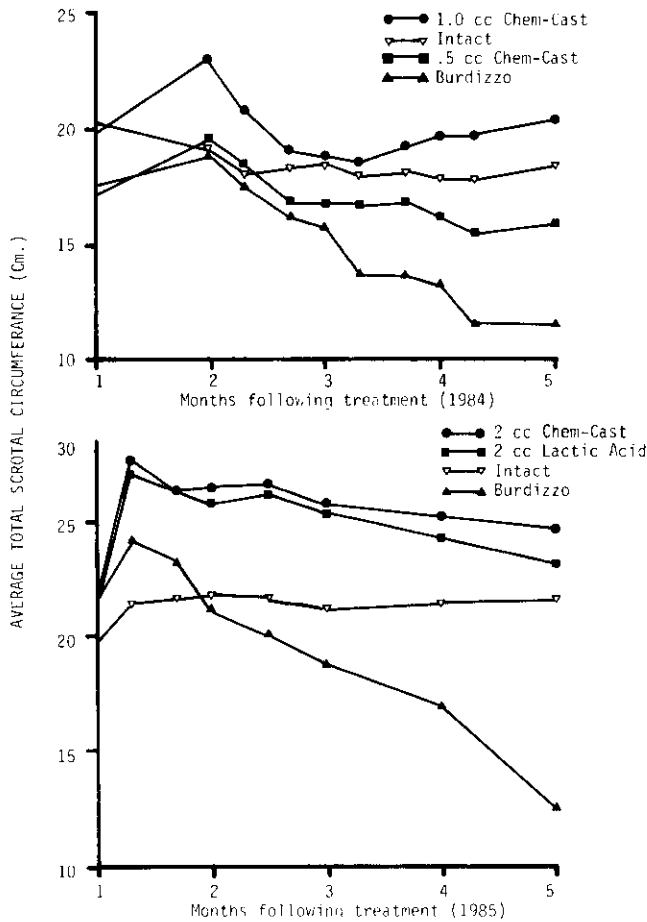

Figure 1. Changes in testicular circumference for the 2 years examined.

Table 1. Weight (lb) changes in castrated and intact Angora males

Year	Treatment	N	Initial wt.	Final wt.	Gain
1984	Knife	11	47.7	50.3	2.6
	Burdizzo	17	46.6	53.3	6.7
	Chem-Cast (0.5)	17	51.7	56.6	4.9
	Chem-Cast (1.0)	19	53.7	60.8	7.1
	Intact	10	60.6	65.5	4.9
1985	Knife	8	66.1	82.6	16.5
	Burdizzo	8	74.4	95.0	20.6
	Chem-Cast (2.0)	8	69.4	95.2	25.8
	Lactic Acid (2.0)	8	68.4	92.4	24.0
	Intact	7	60.3	86.0	25.7



Figure 1. Silky lamb (foreground) compared to a normal lamb (background) shortly after birth.



Figure 2. Silky ewe with her normal lamb. Note somewhat unthrifty appearance and tendency for the fleece to shed and become cotted or matted.

normal sheep. Over the years seven lambs were produced from this ewe or from "silky" daughters of the original ewe. Of the seven lambs produced by silky ewes, five, or 71 percent, have shown this abnormal trait. "Silky" males have been produced, but they have not been used for breeding.

Although the ratio of "silky" to normal offspring is greater than the 1:1 ratio which would be expected, the distribution outlined above is consistent with a theory of simple dominance. In addition, only a small number of animals have been involved and a comparison of phenotypic ratios is of limited value.

In Figure 1, a "silky" lamb is compared to a normal lamb. The "silky" condition is characterized by a distinctive glossy appearance due primarily to a lack of crimp in the fibers. The wool is not necessarily finer, but the relative density of fleece has not been determined. At later ages, the fleece of the "silky" animals may tend to shed and will often become cotted or matted (see Figure 2). The original paper stated that the animals produced an oily fleece which has not been observed in the present group. This difference is likely explained by the fact that the original mutation occurred in a Delaine Merino flock which at that time would have had a more oily fleece than present day Rambouillet sheep.

A comparison of the silky fleece with more typical finewool is shown below.

Type	Fiber diam. Microns	Spinning count	Crimps per inch
Tip	22.12	62's	0
Silky Middle	22.14	62's	0-3
Root	21.89	64's	0-3
Finewool	20.6-22.0	64's	15-20

These data suggest that the "silky" fleece was slightly coarser, but this may simply apply to this individual animal. Although a number of observers called the fleece from these animals mohair, the fleece is substantially finer than adult mohair.

Studies of skin histology have not provided a clear cut explanation of the cause of the defect. The condition appears somewhat analogous, but not the same, as that referred to as "doggy" wool in Australia (1).

Also, the original report stated that the animals were unthrifty and had reduced fertility. Reproduction has not been a problem with the animals in this study. There has been a tendency for them to appear unthrifty, but the type of problems observed have not been consistent. For instance, the original animal developed a number of large cutaneous follicular cysts, but to date this has not been observed with other individuals. Australian workers (2) have reported a high incidence of cystic follicles among sheep which produce doggy wool.

Conclusions

Despite inconsistencies in the results, the writers believe that this defect is essentially the same as the original silky, but that it represents a new mutation. In both cases, it appears to act as a dominant which would prevent its remaining unobserved in the finewool

sheep population. At present, the trait is assumed to be undesirable and should be recognized as such by sheep breeders.

Literature Cited

1. Chapman, R.E. 1964. New ideas on the formation of crimp in wool and the cause of doggy wool. *Wool Technology and Sheep Breeding XI*: 19-22.
2. Chapman, R.E. and B.F. Short. 1965. Crimp in wool: The skin Histology of Normal and Doggy-Fleeced Sheep. *Aust. J. Agric. Res.* 16:211-218.
3. Warwick, B.L., S.P. Davis, R.O. Berry, and R.E. Patterson. 1960. "Silky," a dominant mutant in sheep. *Journal of Heredity*. Vol. LI: 39-42.

Acknowledgement

The authors would like to acknowledge the assistance of Dr. C. J. Lupton in providing the fleece data and Mr. Steve Byrns for assistance with the photographs.

PR-4392

The Effect of Supplemental Feeding on Roughage Utilization by Sheep

D. Reeh and M. Shelton

Decisions concerning supplemental feeding are among the most important that a rancher makes on a day-to-day basis. Rigid guidelines cannot always be provided because of variable environmental, animal, or range conditions. The term supplemental feeding implies that a roughage source is available on the range but is deficient in specific nutrients which can be provided in supplements to obtain a biological as well as an economic response. This is not always easily accomplished.

In recent years, an alkali-treated grain often called "chocolate mealies" has been used extensively in South Africa. Alkali and urea are absorbed into the grain or adhered to it with molasses. These ingredients are used to improve protein content and reduce the likelihood of acidosis from overeating. Also, recent work in Australia has shown that under extremely poor conditions, the grazing animal may respond to non-protein nitrogen (NPN), fed as a lick or with salt.

A brief study was conducted at San Angelo to test some of these practices. Twenty-five aged Rambouillet ewes were divided into five lots and treated as follows:

T1—Ground sorghum hay (protein 4.76 percent) fed free choice as a roughage source,

T2—*ad lib* sorghum hay plus alkali-treated grain free choice,¹

¹The exact formulation of the alkali-treated grain, the urea block, or the cottonseed meal supplement can be provided on request.

T3—Ground sorghum hay *ad lib* plus whole sorghum at the same level of intake as the grain consumption of T2 above,

T4—Ground sorghum hay *ad lib* plus access to an NPN block,¹

T5—Ground sorghum hay *ad lib* plus 0.5 lb daily of a cototnseed meal sorghum grain supplement.

The results of the 47-day feeding period are outlined below.

Treatment	Hay consumption lb per day	Supplement consumption lb per day	Body weight change-lb
T1-Control (hay only)	2.27	—	-1.8
T2-Control + alkali grain	.72	2.25	17.4
T3-Control + whole sorghum grain	.67	2.55	15.4
T4-Control + urea block	2.22	.09	5.6
T5-Control + CSM-sorghum grain supplement	2.27	.50	16.8

The most noticeable aspect of these data is the degree to which supplemental energy fed at a high rate merely substituted for roughage intake, but it should be noted that a gain response was obtained from the greater energy value of the grain. There is no indication that alkali-treated grain is markedly superior to untreated grain. However, no acidosis problems were encountered with this small number of sheep. The protein supplements did appear to show a response and, in this case would be the most economical treatments.

PR-4393

Effects of Lasalocid, Energy, and Protein on Performance of Ewe Lambs

M.M. Mankusa, M.C. Calhoun,
G.R. Engdahl, S.W. Kuhlmann,
and C.S. McCown

Summary

Ninety-six Rambouillet ewe lambs with an average initial live weight of 95 ± 1 lb were used to examine the effects of two dietary levels of lasalocid (0 and 25 g/ton), digestible energy (1.2 and 1.4 Mcal/lb), and crude protein (8 and 12 percent) on feedlot performance and ration digestibility. The diets were composed of sorghum grain, sorghum-sudangrass hay, and cototnseed meal. The feeding period was 84 days.

Lasalocid decreased feed intake 11.9 percent ($P < .01$) and reduced feed requirements for gain 10.7 percent ($P < .01$). Increasing digestible energy from 1.2 to 1.4 Mcal/lb increased live weight gain 30.4 percent ($P < .01$), increased feed intake 7.8 percent ($P < .01$), and decreased feed requirements for gain 17.1 percent ($P < .01$). Increasing dietary crude protein from 8 to 12 percent increased live weight gain 14.1 percent ($P < .01$), increased feed intake 4.6 percent ($P < .05$) and decreased feed requirements for gain 8.1 percent ($P < .05$). There were lasalocid x digestible energy interactions for live weight gain ($P < .01$) and feed intake ($P < .05$). Live weight gain was depressed when lasalocid was added to the higher energy diet, but was increased when lasalocid was added to the lower energy diet. The reduction in feed intake was greatest when lasalocid was added to the higher energy diet. There were no digestible energy x crude protein or lasalocid x crude protein interactions for any of the performance criteria. Lasalocid increased the apparent digestibility of dry matter, organic matter, crude protein, neutral detergent fiber, and acid detergent fiber; however, none of these differences were significant.

Introduction

Lasalocid, an antibiotic feed additive derived from the fermentation of *Streptomyces lasaliensis*, is effective in controlling coccidiosis in sheep (7,9). It is approved for this use in diets of feedlot lambs at levels of 20 to 30 g/ton of feed. Lasalocid also improves performance of feedlot lambs that do not have a coccidial infection. In three such studies, the improvement in live weight gain varied from 3.7 to 23.7 percent and the reduction in feed requirements for gain from 7.0 to 11.5 percent in lambs receiving 25 to 30 g of lasalocid per ton of feed (9,13,14).

Research with monensin, a chemical compound closely related to lasalocid, indicates a much greater response when monensin is added to higher roughage diets than when added to high grain diets typical of those used in lamb feedlots in Texas (3). Monensin has also been shown to have a protein-sparing effect; thus, the response to monensin is often greater in diets when protein is limiting performance (2,10). This research was conducted to examine the possibility that response to lasalocid may also be dependent upon the energy and protein concentrations of lamb diets.

Experimental Procedures

Ninety-six rambouillet ewe lambs from the Angelo State University flock were used for this study. They were randomly assigned to 16 pens with 6 lambs per pen (2 pens/treatment). All animals were vaccinated against enterotoxemia (*Clostridium perfringens* Type D, 2 ml per lamb injected subcutaneously) and given an anthelmintic (Tramisol®).¹ The lambs were fed in the pens for a 2-week adjustment period prior to starting

¹Tramisol® - American Cyanamid Co., .25 g of levamisole hydrochloride was given to each lamb in 20 ml of water using an automatic drench gun.

Table 1. Percentage ingredient composition of experimental diets

Ingredients	1.2 Mcal DE/lb		1.4 Mcal DE/lb	
	8%CP	12%CP	8%CP	12%CP
Sorghum grain, milo	23.00	17.00	59.00	53.25
Sorghum-sudangrass hay	65.50	60.00	33.50	28.00
Cottonseed meal	3.00	15.00	0.00	11.50
Sugarcane molasses	6.00	6.00	5.00	5.00
Dicalcium phosphate	0.75	0.00	0.50	0.00
Calcium carbonate	0.75	1.00	1.00	1.25
Trace mineral and vitamin premix ^a	1.00	1.00	1.00	1.00

^aThe composition of the trace mineral and vitamin premix was: plain mixing salt (NaCl), 83%; elemental sulfur, 15%; zinc oxide, .49%; manganese sulfate, .73% and vitamin A acetate (13.6×10^6 IU/lb), .73%.

Table 2. Effects of lasalocid (L), dietary digestible energy (DE), and crude protein (CP) levels on the performance of ewe lambs

Criterion	Lasalocid ^a		L ^d effects	Digestible energy ^b		DE ^d effects	Crude protein ^c		CP ^d effects	Interactions ^d
	g/ton			Mcal/lb			%			
	0	25		1.2	1.4		8	12		
Live weight gain, lb/day	.421	.414	NS	.362	.472	P<.01	.390	.445	P<.01	EXL (P<.01)
Feed intake, lb/day	4.70	4.14	P<.01	4.25	4.58	P<.01	4.32	4.52	P<.05	EXL (P<.05)
Feed/gain	11.2	10.0	P<.01	11.7	9.7	P<.01	11.1	10.2	P<.05	—

^aValues for lasalocid levels, in this table, are averages across all digestible energy and crude protein levels.

^bValues for digestible energy levels, in this table, are averages across all lasalocid and crude protein levels.

^cValues for crude protein levels, in this table, are averages across all lasalocid and digestible energy levels.

^dNS = No significant difference; EXL = Digestible energy level \times lasalocid level interaction.

the experiment. The experimental period was 84 days.

The diets were based on sorghum grain, sorghum-sudangrass hay and cottonseed meal (Table 1). Lasalocid² was fed at levels of 0 and 25 g/ton in diets containing either 1.2 or 1.4 Mcal digestible energy (DE) per pound of feed and either 8 or 12 percent crude protein. The study was a 2x2x2 factorial with two replications.

Diets were fed ad libitum and lambs were weighed every 28 days. Fecal grab samples were collected from two lambs (randomly selected) in each pen at 0, 28, 56, and 84 days. These samples were used for determination of fecal coccidial oocyst numbers, according to the McMasters egg counting technique (4).

At day 64 chromic oxide powder (.5 percent) was incorporated into all diets and used as an indirect indicator of digestibility (11). Fecal samples were collected from all sheep on day 71. These samples were used for determination of the effect of lasalocid on digestibility of dry matter, organic matter, acid and neutral detergent fiber and crude protein.

Analyses of dry matter, ash, and organic matter of fecal and diet samples were accomplished according to methods outlined by Harris (8). Acid and neutral

detergent fiber were determined by the methods of Fonnesebeck and Harris (5,6). Crude protein was measured by the Kjeldahl procedure (1).

The analysis of variance for a completely random 2x2x2 factorial arrangement of treatments was used in the statistical treatment of the data (12).

Results and Discussion

Fecal coccidial oocyst counts were zero in all lambs sampled initially and remained low throughout the experiment. The highest oocyst counts were obtained for the fecal samples collected at 84 days from lambs not fed lasalocid (713 oocysts/g). In lambs fed lasalocid the value was 19 oocysts/g. These numbers indicate that coccidiosis was not a problem during this experiment and responses to lasalocid were not dependent upon its role as a coccidiostat.

The main effects of dietary levels of lasalocid, digestible energy, and crude protein on the performance of ewe lambs are summarized in Tables 2 and 3. Averaged across all other dietary treatments, the overall effect of lasalocid was to decrease feed intake 11.9 percent (P<.01) and reduce feed requirements for gain 10.7 percent (P<.01). The effect on live weight gains was not significant. However, there were significant interactions between lasalocid and digestible energy content of the diet for live weight gain (P<.01) and feed intake (P<.05). These effects are sum-

²Lasalocid - Bovatec®, Roche Chemical Division, Hoffmann-LaRoche, Inc., Bovatec 68, containing 68 g lasalocid sodium per pound of premix.

Table 3. Percentage changes in performance criteria resulting from different levels of lasalocid, digestible energy and crude protein in the diet

Criterion	Treatment comparisons		
	Lasalocid (g/ton)	Digestible energy (Mcal/lb)	Crude protein (%)
	0 vs 25	1.2 vs 1.4	8 vs 12
Lightweight gain	- 1.7	30.4	14.1
Feed intake	-11.9	7.8	4.6
Feed/gain	-10.7	-17.1	- 8.1

Table 4. Effects of lasalocid on performance of lambs fed diets containing different digestible energy concentrations

Criterion	1.2 Mcal DE/lb lasalocid, g/t		1.4 Mcal DE/lb lasalocid, g/t	
	0	25	0	25
Live weight gain, lb/day	.345	.379	.484	.450
Feed intake, lb/day	4.41	4.09	5.00	4.19
Feed/gain	12.8	10.8	10.3	9.3

Table 5. Effects of dietary levels of lasalocid on digestibility coefficients

Criterion	Lasalocid (g/ton)		Statistical effects ^a
	0	25	
Dry matter %	46.4	49.3	NS
Organic matter, %	48.2	51.6	NS
Crude protein, %	35.9	43.9	NS
Neutral-detergent fiber, %	29.0	31.8	NS
Acid-detergent fiber, %	30.6	32.6	NS

^aNS = No significant difference.

marized in Table 4. Live weight gains were depressed when lasalocid was added to the diets containing 1.4 Mcal DE/lb and increased when lasalocid was added to the diets containing 1.2 Mcal DE/lb. Although feed intake was reduced when lasalocid was added to all diets, the reduction in feed intake was greatest when lasalocid was added to the higher energy diets.

Increasing the digestible energy content of the diet from 1.2 to 1.4 Mcal/lb increased live weight gains 30.4 percent ($P < .01$), increased feed intake 7.8 percent ($P < .01$), and decreased feed requirements for gain 17.1 percent ($P < .01$).

Increasing crude protein content of the diet from 8 to 12 percent increased live weight gain 14.1 percent ($P < .01$), increased feed intake 4.6 percent ($P < .05$), and decreased feed requirements for gain 8.1 percent ($P < .05$). Overall, there were no significant digestible energy x crude protein or lasalocid x crude protein interactions which means that responses to crude protein were independent of the lasalocid and energy

levels used in the diets in this study. Responses to crude protein also indicate that 8 percent crude protein is not adequate for growing-finishing lambs. However, since only two levels of crude protein were used, these data do not provide information on the optimum crude protein level for growing sheep.

Lasalocid slightly increased the digestibility of dry matter, organic matter, crude protein, neutral and acid detergent fiber, but the differences were not significant (Table 5).

Literature Cited

1. AOAC. 1970. Official methods of analysis (11th Ed.). Association of Official Analytical Chemists. Washington D.C.
2. Bergen, W.C. and D.B. Bates. 1984. Ionophores: their effect on production efficiency and mode of action. *J. Anim. Sci.* 58:1465.
3. Calhoun, M.C., L.H. Carroll, C.W. Livingston, Jr., and M. Shelton. 1979. Effect of dietary monensin on coccidial oocyst numbers, feedlot performance and carcass characteristics of lambs. *J. Anim. Sci.* 49:10.
4. Dunn, A.M. 1978. *Veterinary helminthology* (2nd Ed.). William Heinemann Medical Books, Ltd., London.
5. Foncesbeck, P.V. and L.E. Harris. 1970. Determination of plant cell walls in feeds. *Proc. Amer. Soc. Anim. Sci. Western Sec.* 21:153.
6. Foncesbeck, P.V. and L.E. Harris. 1970. Determination of holocellulose, lignin and silica of plant cell walls. *Proc. Amer. Soc. Anim. Sci. Western Sec.* 21:162.
7. Foreyt, W.J., N.L. Gates, and R.B. Wescott. 1979. Effect of lasalocid and monensin against experimentally induced coccidiosis in confinement-reared lambs from weaning to market weight. *Amer. J. Vet. Res.* 40:97.
8. Harris, L.E. 1970. *Nutrition research techniques for domestic and wild animals*. Vol. I. Lorin E. Harris, Logan, Utah.
9. Horton, G.M.J. and P.H.G. Stockdale. 1981. Lasalocid and monensin in finishing diets for early weaned lambs with naturally occurring coccidiosis. *Amer. J. Vet. Res.* 42:433.
10. Owens, F.N. 1980. Ionophore effect on utilization and metabolism of nutrients-ruminants. P. 17 in *Proc. 1980 Georgia Nutr. Conf., Univ. of Georgia, Athens.*
11. Schneider, B.H. and W.P. Flatt. 1975. *The evaluation of feeds through digestibility experiments*. The Univ. of Georgia Press, Athens.
12. Steel, R.G.D. and J.H. Torrie. 1980. *Principles and procedures of statistics* (2nd Ed.). McGraw-Hill Book Co., New York.
13. Shetaawi, M. and T.T. Ross. 1985. Effect of lasalocid on growth, feed intake and efficiency of feed utilization of lambs. *Proc. Western Sect. Amer. Soc. Anim. Sci.* 36:143.

14. Thomas, V.M. and J.J. Dahmen. 1985. Effect of roughage to concentrate ratio and lasalocid on lamb performance and carcass characteristics. Proc. Western Sect. Amer. Soc. Anim.Sci. 36:480.

PR-4394

The Individual and Combined Use of Antibiotic Feed Additives in Lamb Finishing Rations

R.M. Lewis, C.A. Zometa,
M.C. Calhoun, and M. Shelton

Summary

Seventy-two Rambouillet wether feeder lambs were used to determine the effects of oxytetracycline and lasalocid on rate of gain, feed efficiency and carcass characteristics. Treatments were: a control receiving no antibiotics, an oxytetracycline treatment group, a lasalocid treatment group, and a combined treatment group receiving both antibiotics. The study consisted of a 14-day preliminary phase during which the diet was gradually changed from 37 to 72 percent concentrates and a 62-day finishing phase. Little difference in daily gain or carcass measures was observed among the treatment groups. However, for the combined preliminary and finishing phases and for the finishing phase alone, the lambs fed diets containing lasalocid had the best feed efficiencies.

Introduction

Antibiotics, such as oxytetracycline,¹ are frequently added to lamb finishing rations since they benefit the lamb's overall health by controlling subclinical diseases (5,10). Their inclusion in the diet has also been shown to improve weight gains and increase feed efficiency (2,6,11). Lasalocid,² a polyether ionophore, has recently gained approval as a feed additive for sheep. Ionophores are widely used by cattle feeders since they enhance production efficiency by altering the products of ruminal fermentation and help control feedlot disorders, especially lactic acidosis and bloat (1,3,9). Lamb feeding trials suggest a similar production response can be expected when lasalocid is included in the ration (4,7,8).

Distinguishing features between ionophoric compounds and other antibiotics relates to their mode of action in the body. The tetracycline antibiotics, such as

oxytetracycline, are effective in controlling specific disease causing organisms and in improving rate of gain and efficiency. In contrast, the major effects of ionophores, such as lasalocid, appear to result from their alteration of ruminal fermentation patterns in a manner that enhances the efficiency of feed utilization. In addition, lasalocid is particularly useful in the control of lactic acid producing bacteria in the rumen. This is the organism responsible for acidosis, a serious metabolic disease which occurs when lambs are switched too rapidly from forage to a very high concentrate diet. Lasalocid is also quite effective in controlling coccidiosis in lambs.

Since the effects of oxytetracycline and lasalocid are different, tests were done to see if these feed additives in combination would promote improved performance over each drug separately. However, these drugs are not approved for concomitant use, and producers are faced with a choice when deciding on which drug to use. Therefore, the comparative performance of lambs receiving the individual drugs was also measured.

Experimental Procedure

Seventy-two Rambouillet wether lambs were brought from the range for the trial. Shortly after arrival, the lambs were shorn, drenched with Tramisol[®], and vaccinated with *Clostridium perfringens*, Type D bacterin. Following weighing, they were randomly sorted into 12 groups of 6 lambs each and placed in approximately 12 by 30 feet feeder pens.

The study consisted of four dietary treatments, each applied to three pens of lambs, and fed free choice. The ration formulation was identical for all treatments except for the inclusion of an antibiotic additive in three. The treatments included a control containing no antibiotics, an oxytetracycline treatment, a lasalocid treatment, and a treatment combining the two additives (oxytetracycline/lasalocid). The antibiotics were included at a rate of 30 g/ton feed. It is important to stress that the combined use of oxytetracycline and lasalocid for sheep is not approved by the FDA. Therefore, the lambs receiving oxytetracycline/lasalocid were not sold for slaughter at the close of the study.

The trial consisted of a 14-day preliminary phase and a 62-day finishing phase. During the adaptation phase, the rations were gradually shifted from 37 to 72 percent concentrates; two intermediary rations were mixed by varying the proportions of the preliminary and finishing rations (Table 1).

During the preliminary portion of the study, eight lambs, each from separate feeder pens, exhibited signs of scouring and weight loss and were consequently removed from the trial. In order to assure comparable feeding conditions in each pen, the lightest lamb from each of the remaining four pens was also removed. Total feed consumption for each pen was corrected to account for the intake of the lambs removed from the study. At the start of the finishing phase, each pen held five lambs. An additional lamb was removed late in the trial due to injury. No death losses occurred.

¹Oxytetracycline. Terramycin[®] - Pfizer Inc., TM-50, containing 50 g of oxytetracycline hydrochloride activity per pound of antibiotic premix.

²Lasalocid. Bovatec[®] - Roche Chemical Division, Hoffmann-La Roche Inc, Bovatec 68, containing 68 g lasalocid sodium per pound of premix.

At the close of the 76-day feeding period, lambs in the control, oxytetracycline, and lasalocid groups were slaughtered by a commercial packer. A warm carcass weight was recorded and a carcass yield was determined. Chilled carcasses were scored for estimated percent kidney and pelvic fat, measured for fat cover thickness, and federally quality graded.

Results and Discussion

Initial live weights, daily live weight gains, feed efficiencies, and carcass measurements for each treatment are reported in Table 2. Although performance during the preliminary phase is listed, our difficulty in starting the lambs on feed makes the data somewhat erratic. The low daily gains for the oxytetracycline and oxytetracycline/lasalocid treatments were coupled with low feed intakes. Five of the lambs removed from the trial due to scouring and weight loss were from the treatments without lasalocid. Although our numbers

were too small for any conclusive analysis, these results suggest that lasalocid was perhaps beneficial in controlling lactic acid accumulation in lambs when initially provided with full feed. Because of the variability in responses during the short preliminary phase, subsequent discussion will focus on performance during either the finishing phase or the combined preliminary and finishing phases, henceforth called overall performance.

The oxytetracycline/lasalocid treatment showed greater feed efficiency than did the other rations; however, the difference was only significant in the finishing phase. The interaction of the two antibiotics was not statistically significant in either the finishing or overall period, although nearly so in the former. This finding suggests that these additives may compliment each other. However, additional studies with larger numbers of animals will be required to substantiate this conclusion.

Table 1. The ingredient composition of the rations (percentage basis)

Ration ^a (days)	Cracked milo	Cotton seed hulls	Cotton seed meal	Dehy. alfalfa	Molasses	Urea	Vitamins and minerals
Preliminary							
First (1-5)	37.25	40.00	10.00	5.00	5.00	.50	2.25
Second (6-9)	48.92	30.00	8.33	5.00	5.00	.50	2.25
Third (10-14)	60.58	20.00	6.67	5.00	5.00	.50	2.25
Finishing (15-76)	72.25	10.00	5.00	5.00	5.00	.50	2.25

^aRefers to the rations fed during the preliminary or finishing phase of the study. Days refers to the days the given ration was fed.

Table 2. Effects of antibiotic feeding on the performance of lambs

Measurement	Control	Oxytet. ^a	Lasalocid ^b	Oxytet./ lasalocid ^c
Number of lambs	15	15	14	15
Initial weight (lb)	66.0	68.6	67.7	68.8
Feed lot performance:				
Daily gain (lb):				
Preliminary phase	.62	.45	.68	.36
Finishing phase	.53	.52	.52	.56
Overall	.55	.51	.55	.52
Feed/lb gain:				
Preliminary phase	5.2	6.6	4.7	7.1
Finishing phase	7.7	7.7	7.6	6.6
Overall	7.1	7.5	6.9	6.6
Carcass measures:				
Carcass weight (lb)	58.6	58.5	59.0	—
Dressing percent	54.7	54.6	54.0	—
Kidney-pelvic fat (%)	2.6	2.4	2.3	—
Fat cover (in)	.27	.25	.28	—
Carcass grade	CH+	CH+	CH+	—

^aOxytetracycline. Terramycin®—Pfizer Inc., TM-50, containing 50 g of oxytetracycline hydrochloride activity per pound of antibiotic premix.

^bLasalocid. Bovatec®—Roche Chemical Division, Hoffmann-La Roche Inc, Bovatec 68, containing 68 g lasalocid sodium per pound of premix.

^cThe combined use of oxytetracycline and lasalocid is not approved by the FDA. The lambs receiving this ration were not sold for slaughter.

Table 3 compares the gains and feed efficiencies observed for the oxytetracycline and lasalocid treatments for the finishing phase and overall. Daily gains did not significantly differ among the treatment groups during either the finishing or overall periods, averaging .53 lb daily. However, feed efficiencies for the lasalocid treatments were significantly better than for those treatments lacking the ionophore, namely, 7.1 and 6.7 lb feed/lb gain for the lasalocid treatments versus 7.7 and 7.3 lb feed/lb gain for the non-lasalocid treatments in the finishing and overall periods, respectively. In other words, an approximate 8 percent improvement in efficiency was achieved when lasalocid was included in the diet. No significant difference in feed efficiency was noted in either period for the treatments with oxytetracycline. The greater feed efficiency, however, of the oxytetracycline treatment groups over the non-oxytetracycline treatments during the finishing phase, a difference in efficiency comparable to the lasalocid treatment groups, was nearly significant.

There were no significant effects of oxytetracycline or lasalocid on any of the carcass measures. Carcass weights averaged 58.7 lb with a dressing percentage, calculated from the final live weights and warm carcass weights, of 54.4 percent. A majority of the carcasses were federally graded as choice-plus and had 2.4 percent kidney and pelvic fat and a .27 inch external fat cover measured over the 12th rib (Table 2).

Since the objective of a feedlot operator is to make a profit, the relative cost of producing a pound of live gain is of importance. The feed cost for the ration employed in the trial was estimated as \$5.50/cwt. The most efficient overall gains were realized with the treatment including both antibiotics with a feed cost of 39.1 cents per pound of gain. The comparative feed cost of the control ration was 42.4 cents per pound of gain. Although several additional factors affect production costs besides feed, at a feed cost savings of 3.3 cents for every pound of gain, the use of an antibiotic

Table 3. The effects of oxytetracycline and lasalocid on performance during the finishing phase and the overall trial

Measurement	Oxytetracycline ^a		Lasalocid ^b	
	0 g/ton	30 g/ton	0 g/ton	30 g/ton
Finishing phase:				
Daily gain (lb)	.52	.54	.52	.54
Feed/lb gain ^c	7.7	7.1	7.7	7.1
Overall trial:				
Daily gain (lb)	.55	.51	.53	.54
Feed/lb gain ^d	7.0	7.0	7.3	6.7

^aOxytetracycline. Terramycin®—Pfizer Inc., TM-50, containing 50 g of oxytetracycline hydrochloride activity per pound of antibiotic premix.

^bLasalocid. Bovatec®—Roche Chemical Division, Hoffmann-La Roche Inc, Bovatec 68, containing 68 g lasalocid sodium per pound of premix.

^cLasalocid treatment differences significant at P<0.05.

^dLasalocid treatment differences significant at P<0.01.

feed additive, in this instance lasalocid, would likely be worthwhile. The reduction in health disorders and death losses also realized when these products are included in the diet further supports their usefulness to the lamb feeding industry.

Literature Cited

1. Bergen, W.G. and D.B. Bates. 1984. Ionophores: their effect on production efficiency and mode of action. *J. Anim. Sci.* 59:1465.
2. Calhoun, M.C. and M. Shelton. 1973. Effect of chlorotetracycline and sulfamethazine supplementation on the performance of lambs fed a high concentrate diet. *J. Anim. Sci.* 37:1433.
3. Elsasser, T.H. 1984. Potential interactions of ionophore drugs with divalent cations and their function in the animal body. *J. Anim. Sci.* 59:845.
4. Foreyt, W.J., S.M. Parish, and K.M. Foreyt. 1981. Lasalocid for improved weight gains and control of coccidia in lambs. *Amer. J. Vet. Res.* 42:57.
5. Gregory, M.W., L.P. Joyner, and J. Catchpole. 1981. Medication against ovine coccidiosis - a review. *Vet. Res. Communications* 5:307.
6. Hays, V.W. 1969. Biological basis for the use of antibiotics in livestock production. pp. 11-30 in *The use of drugs in animal feeds*. National Academy of Sciences Publication 1679, Washington, D.C.
7. Horton, G.M.J., E.H. Keeler, and K.A. Bassendowski. 1981. Performance of lambs and steers given monensin with different levels of barley. *Anim. Prod.* 32:267.
8. Horton, G.M.J. and P.H.G. Stockdale. 1979. Effects of amprolium and monensin on oocyst discharge, feed utilization, and ruminal metabolism of lambs with coccidiosis. *Amer. J. Vet. Res.* 40:966.
9. Nagaraja, T.G., T.B. Avery, E.E. Bartley, and S.K. Roof. 1982. Effects of lasalocid, monensin or thiopeptin on lactic acidosis in cattle. *J. Anim. Sci.* 54:649.
10. Ott, E.A. 1968. Use of feed additives for lambs. P206 in *Proc. Symposium on Sheep Nutrition and Feeding*. Ames, IA.
11. Pope A.L. 1975. The role of silages, feed additives, and less common feed substances in ovine nutrition. *J. Amer. Vet. Med. Assoc.* 166:263.

Acknowledgements

We appreciate the cooperation of Mr. Ray Ellis, manager of the Swift Independent Packing Company of San Angelo, in the slaughter and carcass evaluation of the study lambs.

Forage and Total Nutrient Intake in Kid, Yearling, and Adult Angora Goats Fed Three Levels of Supplemental Energy

J.E. Huston and B.S. Engdahl

Summary

Forage intake and total nutrient intake were measured in kids, yearlings, and adult Angora goats that grazed rangeland and were supplemented with a constant amount of protein but increasing amounts of concentrated energy. Forage intake was highest at the low supplemental feeding level for kids and at the medium feeding level for yearlings and adults. These increases in forage intake possibly resulted from the additional protein contained in the supplemental feed. Forage intake was lowest at the high feeding level, suggesting a substitution effect when large amounts of concentrate energy was fed. Total energy intake was highest at the high level of supplementation but total protein intake followed forage intake and was depressed at the high feeding level. Feeding high energy feeds may depress protein which would partially explain the poor results often seen when high energy supplements are fed.

Introduction

Angora goats have high nutrient requirements in comparison with other livestock species (2). The inability of goats to satisfy these high requirements on range may account for the low reproductive rates normally observed in goats. However, reproductive performance can be increased if females are fed to reach a large body size prior to first breeding (3). This study was conducted to measure the effect of feeding increasing amounts of digestible energy to kid, yearling, and adult Angora females on forage intake and total nutrient intake.

Experimental Procedure

Five kids (9 months), five yearlings (21 months) and five adults (2-3 years) were assigned to each of four treatment groups (Table 1) for an 85-day experiment (Dec. 20 - Mar. 15) that included a forage intake determination at 1 week prior to the beginning of kidding.

Management and Feeding. The yearling and adult goats were exposed to fertile males for 60 days beginning Oct. 1. The goats were fed one-third of their weekly allowances in three equal feedings per week on an individual animal and weight basis (Table 1). This feeding activity usually required about 2 hours per feeding. At other times, all groups grazed rangeland in common. The supplemental rations and feeding levels were selected to achieve predetermined spacing of treatments and are not necessarily recommended

Table 1. Supplemental feeds and feeding rates in a study of effects of increasing supplemental energy for kids, yearlings and adult goats

Item	Treatment			
	Control	Low	Medium	High
Ration:				
Sorghum grain, %	0	14	67	97
Cottonseed meal, %	0	83	30	—
Molasses, %	0	3	3	3
	0	100	100	100
DE, kcal/g ^a	0	3.0	3.3	3.5
CP, % ^b	0	35.6	19.4	10.3
Feeding levels:				
g/kg ^{.75c}	0	8.4	15.1	28.7
kcal/kg ^{.75}	0	25	50	100
g CP/kg ^{.75}	0	3	3	3

^aDigestible energy, equivalent to 68, 75 and 79% TDN.

^bCrude protein.

^cApproximately .22, .40 and .75 lb/day, respectively, for a 60 lb goat.

for any particular circumstance. However, these feeds and feeding levels are similar to practices commonly observed in practical situations.

Intake Determination. Intake was calculated from total feces estimations obtained using the indigestible marker, ytterbium nitrate, with the pulse-dose procedure (1). Total feces was corrected to feces derived from forage by subtracting the estimated fraction of feces contributed by the concentrate feeding. A hand collected forage sample was obtained in an attempt to duplicate diet selection and was used to estimate diet digestibility. Forage intake was calculated from feces derived from forage and diet digestibility. Total intake included concentrate and forage intake. The goats were fed daily (appropriate daily feed level) for four days prior to and during the 4-day intake determination.

Results and Discussion

Very little difficulty was encountered with refusal of goats to consume their assigned concentrate. Essentially all goats were consuming the assigned ration and amounts by the time the intake determination was conducted. Levels of forage consumption were generally in order of body size (adults > yearlings > kids; Table 2), although on a body weight basis (not shown), forage consumption was lowest in yearlings. In each class of goat, forage intake increased at either the low (kids) or medium (yearlings and adults) level, and then declined at the high level of supplemental energy. In kids and adults, total intake at the high energy supplementation level was lower than at the respective peak intermediate level. However, total digestible energy intake was highest for each class of goat at the high energy supplementation level. On the other hand, because protein intake from concentrate was constant across all supplementation levels, total protein intake in the supplemented groups followed forage intake. That is, protein intake was highest for kids

Table 2. Forage and total energy intake by kid, yearling and adult goats fed increasing supplemental energy

Item	Treatment			
	Control	Low	Medium	High
Dry Matter Intake, g/d				
Kids				
Concentrate	0	62	111	210
Forage	463	571	462	410
Total	463	633	573	620
Yearlings				
Concentrate	0	91	160	321
Forage	525	521	607	495
Total	525	612	767	816
Adults				
Concentrate	0	110	189	352
Forage	752	731	892	660
Total	752	841	1081	1012
Nutrient Intake				
Digestible energy, Mcal/d				
Kids	.81	1.19	1.18	1.46
Yearlings	.92	1.19	1.60	1.99
Adults	1.32	1.62	2.19	2.39
Crude protein, g/d				
Kids	32.4	62.0	53.9	50.3
Yearlings	36.8	68.9	73.5	67.7
Adults	52.6	90.3	99.1	82.5

Table 3. Energy and protein requirements for different classes of Angora goats for high production

Class of goat	Average weight, lb	Nutrient requirements ^a	
		DE, Mcal/d	CP, g/d
Kids	36.4	1.54	62.4
Yearlings, pregnant	61.0	3.74	157.3
Adults, pregnant	73.6	4.01	175.1

^aNRC (1981).

receiving the low energy supplement and for yearlings and adults receiving the medium energy supplement. In each case, protein intake was lowest in the control animals but second lowest in those receiving the high energy supplement.

Several workers have suggested that energy supplements decrease the animal's ability to utilize fiber in forages. Perhaps these data provide a partial explanation of why energy supplements often give disappointing results. Nutrient requirements for high level production is extremely high for goats (Table 3) and both energy and protein intakes are frequently below optimum. Energy supplements that substitute for forage intake may reduce protein intake to a point at which no improvement in animal productivity can be observed.

Literature Cited

1. Ellis, W.C., J.H. Matis, and C. Lascano. 1979. Quantitating ruminal turnover. *Fed. Proc.* 38:2702.

2. NRC. 1951. Nutrient requirements of goats: angora, dairy, and meat goats in temperate and tropical countries. National Academy Press. Washington, D.C.
3. Shelton, M. and J. Groff. 1974. Reproductive efficiency in Angora goats. *Tex. Agr. Exp. Sta. Bull.* 1136.

PR-4396

A Comparison of Rumensin and Bovatec at Increasing Levels in Supplemental Feed for Lambs and Angora Kids on Rangeland^{abc}

J.E. Huston, M.C. Calhoun,
and B.S. Engdahl

Both Rumensin and Bovatec are effective drugs for improving feed conversion in feedlot lambs at 10 to 30 g/ton of feed. Both are also effective in the prevention of coccidiosis, a particularly troublesome condition for young Angora goats. Range studies with growing cattle have yielded variable responses to Rumensin fed at different levels.

A study was conducted to determine the influence of levels of Rumensin and Bovatec in supplemental feed on acceptability of the feed, forage intake, and rumen volatile fatty acid (VFA) levels in 60 lambs and 60 Angora kid goats (10 to 12 months of age) grazing rangeland. The lambs and kids were fed a supplemental feed containing 78 percent sorghum grain, 19 percent cottonseed meal and 3 percent molasses (approximately 16 percent crude protein and 76 percent total digestible nutrients) at a level (15 g/kg live wt⁷⁵) to supply one-half of daily protein and one-third of daily energy requirements (based on sheep requirements). Treatments included a negative control (no feed), positive control (feed without drugs) and supplemental feed containing either 30, 60, 90, 120 or 150 g/ton of either Rumensin or Bovatec. Animals offered supplemental feed were penned and fed their respective feed allowances, then returned to pasture. Feed refusals were measured.

After 18 days of preliminary feeding, a forage intake determination was made using the pulse-dose

^aRumensin®- Monensin sodium, a product of Eli Lilly and Company, Indianapolis, Indiana 46206, is not cleared for use in a pasture supplement for sheep or goats.

^bBovatec®- Lasalocid sodium, a product of Hoffmann - La Roche Inc., Nutley, New Jersey 07110, is not cleared for use in pasture supplement for sheep or goats.

^cThe animals used in this study were experimental animals and were not slaughtered.

procedure. Rumen samples were taken for VFA determination by a gas-liquid chromatographic technique. Supplement intake measurements indicate that goats are more tolerant than sheep to consuming feeds containing high levels of Rumensin and that sheep are more tolerant of Bovatec than Rumensin fed at high levels. Analyses for forage intake and rumen VFA concentrations are incomplete at present. When complete, the data will be used to determine the relative effective ranges of the two drugs and whether their effects are different for sheep and goats.

PR-4397

Intake and Digestibility in Sheep and Goats Fed Three Forages With Different Levels of Supplemental Protein

J. E. Huston, B. S. Engdahl, and K. W. Bales

Summary

The influences of forage quality and supplemental protein on forage intake and digestibility were studied using confined Rambouillet sheep and Angora goats. With a low quality forage (wheat straw), intake was lower and digestibility was higher in goats than in sheep. No differences in digestibility of medium quality (sorghum hay) and high quality (oat hay) forages between sheep and goats were observed. Both species responded to supplemental protein with the low quality forage (wheat straw) by increasing forage intake. With medium and high quality forages (sorghum hay and oat hay, respectively), goats increased intake at higher levels of supplemental protein compared with sheep.

Introduction

Sheep and goats often occupy similar but not identical positions in range and pasture grazing schemes. The two species display different diet selection tendencies; yet, under a given set of circumstances, diet composition may be very similar. Whether the species differ in capabilities of ingesting and digesting forages is not as well clarified (2). This experiment, in which both sheep and goats were provided an array of diets varying in fiber and nitrogen content, provides a basis for clarification.

Experimental Procedure

A series of digestion trials was conducted with sheep and goats fed three forages either unsupplemented or with one of three levels of supplemental protein. The animals received proper care and humane treatment at all times during the study.

Description of Animals. Rambouillet sheep and Angora goats were used in 12 trials involving 60 sheep and 60 goats. Ages of the animals were between 8 months

and 4 years; but within each trial, the ages of the 10 animals were within 3 months. The animals were fed the experimental forage free-choice in groups (sheep and goats held separately) in outdoor pens for 7 to 14 days before being placed in digestion stalls.

Description of Experimental Diets. The forages studied were oat hay, sorghum hay, and wheat straw (Table 1). The forages were ground with a high speed hammer-mill through a 2 cm screen. Sorghum grain (SG) and cottonseed meal (CSM) were used to make supplements to supply approximately 700 kcal of digestible energy and either 20 (low), 40 (medium) or 60 g (high) crude protein (CP) per animal daily. Animals designated to receive the control treatment (control) were fed forage only.

Digestion Trial Procedures. The animals were held in digestion stalls for 14 to 21 days. An adjustment period of 7 to 14 days and a collection period of 7 to 10 days was used for each trial. The supplements were fed at 800 hours and the animals were allowed 1 hour before refusals (if any) were removed and forage offered. During the adjustment period the animals were brought to a relatively constant ad libitum intake of forage. Water was offered free-choice. Forage and supplement intake were measured and feces was collected and sampled daily. All trials were conducted during the warm months (June to early November) although not in the same year.

Analytical Procedures. The forages and supplemental feed ingredients were analyzed for dry matter (DM) and CP (1), in vitro digestible dry matter (IVDDM; 6) and potentially digestible dry matter (PDDM; 4).

Data were analyzed by least squares analysis of variance for a mixed model (5). Forages and supplemental feeds were considered random variables and animal species was treated as a fixed variable.

Results and Discussion

Forages in the study varied in composition from a low of 3.4 percent CP and 40.8 percent IVDDM for wheat straw to a high of 13.8 and 64.8 percent (CP and IVDDM, respectively) for oat hay (Table 1). Sorghum hay contained intermediate amounts of each. Potentially digestible dry matter is a theoretical fraction of the forage that has potential for digestion and is

Table 1. Composition of dietary components in digestion trials with sheep and goats

Dietary materials	CP ^a	Percent	
		IVDDM ^b	PDDM ^c
Wheat straw	3.4	40.8	69.9
Sorghum hay	5.9	53.7	79.6
Oat hay	13.8	64.8	86.7
Sorghum grain	10.7	82.6	97.6
Cottonseed meal	44.1	70.6	87.2

^aCrude protein.

^bIn vitro digestible dry matter (48 hours).

^cPotentially digestible dry matter (144 hours).

Table 2. Dry matter intake and forage digestibility (DMD) in sheep and goats fed three forages with different levels of supplemental protein (CP)

Item	Wheat straw		Sorghum hay		Oat hay	
	Sheep	Goats	Sheep	Goats	Sheep	Goats
Number of animals	20	20	20	20	20	20
Average weight, kg	51.2	26.3	54.2	27.3	48.0	23.6
Intake, g/kg ⁷⁵						
Concentrates						
Control	0	0	0	0	0	0
Low CP ¹	10.0	16.4	9.0	17.1	10.0	17.1
Med CP	9.8	15.7	9.3	15.5	10.6	18.7
High CP	10.5	16.7	9.7	17.2	11.2	19.8
Forage						
Control	29.1	19.2	38.7	36.3	64.3	54.4
Low CP	33.2	22.1	35.4	31.3	51.4	52.3
Med CP	37.6	30.8	40.6	45.2	53.6	58.7
High CP	39.0	30.0	39.5	48.4	48.2	61.5
Ave	34.7	25.5	38.6	40.3	54.4	56.7
Total DM ²	42.3	37.7	45.6	52.7	62.4	70.6
Forage DMD ³ , %	42.2	47.2	50.1	51.2	65.8	65.0

¹CP—Crude protein.

²DM—Dry matter.

³DMD—Dry matter digestibility.

comprised of both the digested portion of the diet and the fecal fraction from the diet that remains potentially digestible.

Similarities and differences in intake and digestibility between sheep and goats were not consistent for different forages and levels of supplemental protein (Tables 2 and 3). Forage dry matter intake (FDMI) was influenced by the forage being fed ($P < .05$) but, including all forages, was not affected by animal species ($P > .10$). Forage dry matter digestibility (FDMD) was affected by both forage ($P < .01$) and animal species ($P < .10$). Strong interactions were detected for both FDMI and FDMD between forage and species ($P < .05$). Intake was similar for sheep and goats consuming oat hay and sorghum hay but was higher in sheep when wheat straw was fed. Correspondingly, digestion values of sheep and goats could not be distinguished for either oat hay or sorghum hay, but FDMD was higher for wheat straw in goats. Supplemental feeding affected forage intake by sheep and goats similarly when fed with low quality forage but differently when fed with medium and high quality forages (feed X species interaction, $P < .10$, Table 3).

Brown and Johnson (2) reviewed the current literature and found discrepancies in reported relative values for intake and digestibility in sheep and goats. In general, the species were similar when higher quality forages or mixed diets were fed. Most discrepancies occurred with lower quality forages. The current data concur that with medium and low fiber forages, intake and digestibility are not distinct for sheep and goats. Only with high fiber diets were differences detectable.

The data support the hypothesis that differences in intake and digestibility between sheep and goats were

Table 3. Statistical analyses for differences in forage dry matter intake (FDMI) and forage dry matter digestibility (FDMD) related to forage, supplemental feed and animal species

Sources of effects and interactions	Probability of chance occurrence ^a	
	FDMI	FDMD
Main effects:		
Forage	*	**
Supplemental feed	NS	NS
Animal species	NS	+
Interactions:		
Forage × feed	NS	NS
Forage × species	*	*
Feed × species	+	NS
Forage × feed × species	NS	NS

^aStatistical notations: **— $P < .01$
 *— $P < .05$
 +— $P < .10$
 NS— $P > .10$

attributable to differences between species in their capacity to consume fibrous materials and their responses to higher levels of supplemental protein. With wheat straw, goats appeared to approach a maximum intake which was lower than that for sheep (Table 2). Possibly this level of fiber intake was associated with an extended ruminoreticular retention time as previously observed under similar digestion stall conditions (3). Since the extent of digestion was the net result of rates of digestion and passage, FDMD was greater in goats.

While these data suggested important differences in sheep and goats under the conditions of this study, the

nutritional uniqueness of goats is their diet selection and foraging strategy. In a free grazing situation, goats were observed to select a diet similar in *in vitro* digestibility to that selected by sheep but averaged 37 percent faster ruminoreticular turnover of undigested particles and an 11 percent lower digestibility of consumed diet (3). It is suggested that caution should be exercised when applying results of stall feeding studies to grazing circumstances, especially with goats.

Literature Cited

1. AOAC. 1975. Official methods of analysis (12th Ed.). Association of Official Analytical Chemists, Washington, D.C.
2. Brown, L.E. and W.L. Johnson. 1984. Comparative intake and digestibility of forage and by-products by sheep and goats: a review. *Int. Goat and Sheep Res.* 2:212.
3. Huston, J.E., B.S. Rector, W.C. Ellis, and M.L. Allen. 1986. Dynamics of digestion in cattle, sheep, goats and deer. *J. Anim. Sci.* 62:208.
4. Lippke, H., W.C. Ellis, and B.F. Jacobs. 1986. Recovery of indigestible fiber from feces of sheep and cattle on forage diets. *J. Dairy Sci.* 69:403.
5. Snedecor, C.W. and W.C. Cochran. 1956. Statistical methods (5th Ed.). Iowa State University Press, Ames, IA.
6. Van Soest, P.J., R.H. Wine, and L.A. Moore. 1966. Estimation of true digestibility of forage by the *in vitro* digestion of cell walls. *Proc. 10th Int. Grassl. Cong.* 10:438.

PR-4398

Magnesium, Potassium, and Calcium Absorption and Retention in Sheep Fed Monensin and Potassium

L. W. Greene, G. T. Schelling, and F. M. Byers

Summary

Twelve ruminally cannulated lambs were used to determine the effect of monensin and potassium (K) on absorption of magnesium (Mg), K, and calcium (Ca) in lambs. Lambs were fed a basal diet with or without monensin. Within each monensin group, lambs were infused ruminally with 0, 7.6 or 31.6 g of K per day during three trials. Addition of monensin to the diet decreased ($P < 0.05$) fecal Mg excretion from 0.63 to 0.53 g/day. Apparent absorption and retention of Mg were increased ($P < 0.05$) 28.8 and 181.3 percent, respectively, with the addition of monensin. Increasing K level increased ($P < 0.05$) fecal Mg excretion linearly. Apparent absorption of Mg decreased

($P < 0.05$) from 0.93 to 0.80 g/day when either level of K was infused into the rumen. Monensin decreased the acetate:propionate ratio. There was a significant interaction between monensin and K level for acetate and propionate (molar percent), and acetate:propionate ratio. In the presence of higher levels of dietary K, monensin appears to be more effective in enhancing ruminal fermentation. Based on these results, monensin may be useful in neutralizing K related depressions of Mg absorption in ruminants consuming diets high in K.

Introduction

Magnesium (Mg) availability in the ruminant digestive system decreases with an increased intake of dietary potassium (K; 2, 3). Kirk et al. (4) reported that lambs fed 20 mg/kg monensin-sodium had a 52.4 percent improvement in Mg retention compared to lambs fed the control diet. They reported that the increased retention was brought about by an increased absorption of Mg coupled with less Mg excreted in the urine. Starnes et al. (11) reported an increase in apparent Mg absorption in steers fed ionophores.

The objective of this study was to determine the relative effects of monensin and ruminally infused K on the apparent absorption of Mg in sheep. The effect of monensin and K on the metabolism of calcium Ca and K, and ruminal VFA production were also studied.

Experimental Procedure

Twelve crossbred wether lambs (avg wt, 31.1 kg) surgically equipped with a ruminal cannula were assigned to one of two groups (six lambs per group) and fed a high concentrate diet (Table 1) with or without 20 mg/kg monensin-Na (fed as Rumensin¹) for a 19-day dietary adjustment period. Each group had ad libitum access to their respective diet and group intake was measured daily. Following the diet adjustment period, lambs were randomly placed in metabolism stalls and were fed 450 g of their respective diet twice daily. Within each group, lambs were allotted to one of three levels of ruminally infused K (0, 7.6, 31.6 g/day) during 3 trials in a 3 x 3 Latin square design. Each trial consisted of a 10-day preliminary period and a 7 day collection period to determine mineral balance.

Feed samples were collected at each feeding. The 7-day collection period consisted of total feces and urine being collected daily. At the end of each collection period, fecal collections were weighed, sampled, and ground through a 1-mm screen. The composited feed samples were sampled and ground in the same manner. Daily urine collections were composited, mixed thoroughly and sampled. Feed, feces and urine were analyzed for Mg, Ca, and K by atomic absorption spectrophotometry.

Ruminal fluid samples were obtained 4 to 5 hours post feeding following the last fecal collection using a vacuum pump and flexible tube inserted through the

¹Rumensin® - monensin - sodium, a product of Eli Lilly and Company, Indianapolis, Indiana 46206.

ruminal cannula. Approximately 200 ml of ruminal fluid was collected for each sample and immediately frozen. Volatile fatty acid concentrations in ruminal fluid were determined by gas-liquid chromatography.

Data were analyzed using the General Linear Model (GLM) procedure of the Statistical Analysis System (9). The model statement used in the GLM procedure was: $Y = u + \text{monensin} + \text{animal}(\text{monensin}) + \text{Trial} + \text{K} + (\text{monensin} \times \text{K})$. The effect of monensin was tested using animal (monensin) and K was tested using the residual error. When GLM indicated a K effect, linear and quadratic contrasts were evaluated.

Results and Discussion

Magnesium, K, and Ca concentrations of the basal diet are presented in Table 1. The basal diet was balanced to meet the lambs requirements (8) for Mg, sodium (Na), and phosphorus.

There were not any significant interactions between monensin level and level of infused K for any mineral balance measurement. Therefore, balance data are presented by main effects. Table 2 contains the results of the Mg balance data for lambs fed the control diet with or without 20 mg/kg monensin and ruminally infused with 0, 7.6, or 31.6 g K/day. Lambs fed monensin excreted less ($P < 0.05$) Mg in the feces which

resulted in a 29 percent increase ($P < 0.05$) in the apparent absorption of Mg. The apparent digestibility of Mg increased ($P < 0.05$) from 54.0 to 64.0 percent when lambs were supplemented with monensin compared to those fed the basal diet. Retention of Mg increased ($P < 0.05$) from 0.16 to 0.45 g/day when monensin was added to the basal diet. This agrees with research reported by Starnes et al. (11) that both Mg absorption and retention increased when steers were fed monensin. Monensin's ability to drive the Na-K pump (10) may be a contributing factor for the increased absorption of Mg through the Na-K-ATP-ase-dependent Mg absorption mechanisms proposed by Martens et al. (6). In addition Kirk et al. (4) reported that the retention of Mg increased 52 percent in lambs fed 20 mg/kg monensin.

Increasing the level of infused K from 0 to 7.6 and 31.6 g/day increased ($P < 0.05$) the quantity of Mg excreted in the feces by 13.7 and 23.5 percent, respectively. Greene et al. (3) reported that fecal Mg excretion increased 14.3 and 25.4 percent when lambs were fed 2.4 and 4.8 percent K compared with lambs fed 0.6 percent K. In the present study, apparent absorption of Mg decreased from 0.93 to 0.80 g/day when K was infused into the rumen. This response is similar to that reported by Newton et al. (7) and Greene et al. (2, 3) when lambs were fed high levels of K. The supplementation of monensin to ruminants grazing forages high in K may be advantageous in controlling grass tetany. Lambs fed 20 mg/kg monensin and infused with 31.6 g/day of K absorbed greater quantities of Mg than lambs infused with 31.6 g/day of K without monensin.

Monensin decreased ($P < 0.05$) the fecal excretion and increased ($P < 0.10$) the apparent absorption of K (Table 3). The apparent digestibility of K increased ($P < 0.05$) from 95.8 to 97.1 percent when lambs were supplemented with monensin. Kirk et al. (5) reported that monensin was responsible for a 16.7 percent increase in K absorption and a 52.6 percent increase in K retention. In the present study there was a tendency for lambs fed monensin to retain more ($P > 0.10$) K than those fed the basal diet. However, K retention was negative in lambs of both groups due to large quantities of urinary K when either monensin level was fed. Starnes et al. (11) found no significant changes in the K

Table 1. Ingredient and mineral composition of basal diet fed to lambs

Item	Content % as fed
Ingredient composition, %	
Corn gluten meal (IFN 5-02-900)	7.10
Corn grain (IFN 4-21-018)	71.34
Cottonseed hulls (IFN 1-01-599)	20.00
Limestone (IFN 6-02-632)	1.00
Magnesium oxide	0.06
Trace mineralized salt ^a	0.50
Mineral composition, %	
Magnesium	0.16
Potassium	0.44
Calcium	0.55

^aUnited salt corporation, Houston, TX, NaCl, 93%; Mn, 0.30%; Zn, 0.25%; Fe, 0.15%; Cu, 0.015%; I, 0.009%; Co, 0.005%.

Table 2. Intake, excretion, absorption and retention of magnesium in lambs fed monensin and ruminally infused with three levels of potassium

Item	Monensin level, mg/kg			SE	Level of infused potassium, g/day			SE
	0	20			0	7.6	31.6	
Intake ^a	1.36	1.46		0.04	1.44	1.38	1.43	0.05
Excretion								
Feces ^{ab}	0.63	0.53		0.04	0.51	0.58	0.63	0.05
Urine ^b	0.57	0.48		0.11	0.69	0.56	0.29	0.14
Absorption ^{ab}	0.73	0.94		0.04	0.93	0.80	0.80	0.05
Retention ^a	0.16	0.45		0.12	0.25	0.24	0.51	0.15

^aAffected by monensin ($P < 0.05$).

^bLinear effect of potassium ($P < 0.05$).

Table 3. Intake, excretion, absorption and retention of potassium in lambs fed monensin and ruminally infused with three levels of potassium

Item	Monensin level, mg/kg			Level of infused potassium, g/day			
	0	20	SE	0	7.6	31.6	SE
Intake + infused	15.59	15.87	0.17	4.07	11.53	35.17	0.21
Excretion							
Feces ^{ab}	0.65	0.46	0.08	0.35	0.55	0.76	0.10
Urine ^a	17.22	17.33	2.37	3.30	13.31	39.20	2.90
Absorption ^c	14.94	15.41	0.21	3.71	10.98	34.41	0.25
Retention	-2.27	-1.9	2.37	0.41	-2.32	-4.80	2.91

^aLinear effect of potassium ($P<0.05$).

^bAffected by monensin ($P<0.05$).

^cQuadratic effect of potassium ($P<0.05$).

Table 4. Intake, excretion, absorption and retention of calcium in lambs fed monensin and ruminally infused with three levels of potassium

Item	Monensin level, mg/kg			Level of infused potassium, g/day			
	0	20	SE	0	7.6	31.6	SE
Intake ^{ab}	4.65	5.47	0.28	5.35	5.13	4.74	0.34
Excretion							
Feces	3.16	3.03	0.24	3.14	3.27	2.80	0.29
Urine ^b	0.06	0.08	0.03	0.03	0.04	0.16	0.04
Absorption ^a	1.49	2.45	0.21	2.22	1.87	1.93	0.26
Retention ^{ab}	1.43	2.36	0.11	2.19	1.83	1.77	0.14

^aAffected by monensin ($P<0.05$).

^bLinear effect of potassium ($P<0.05$).

balance of steers fed with or without monensin.

Ruminal infusion of K increased ($P<0.05$) fecal and urinary excretion and absorption of K. Apparent availability of K increased ($P<0.05$) from 91.2 to 95.2 and 97.8 percent when 7.6 and 31.6 g/day of K were infused into the rumen. This increase in apparent availability of K is probably not due to a change in true digestibility but a reflection of the relative contribution of endogenous fecal K. The response of increasing dietary K on K balance is similar to data reported by Newton et al. (7) and Greene et al. (2, 3). Charles and Duke (1) reported that broiler chicks fed monensin along with supplemental K had increased rates of growth vs. those receiving monensin alone, suggesting that monensin increased their dietary K requirement. However, in the present study, there was not a significant interaction between the monensin and K in the balance data. Calcium absorption (Table 4) was increased with the addition of monensin to the basal diet. The apparent availability of Ca increased ($P<0.05$) from 32 to 45 percent when lambs were fed monensin. This increase in Ca absorption resulted in a 65 percent improvement in Ca retention. Starnes et al. (11) indicated that the addition of monensin did not alter Ca balance. Kirk et al. (4) reported a 60 percent decrease in urinary Ca excretion in lambs fed monensin but this change had little impact on overall Ca balance. Cal-

cium absorption was not altered by the addition of K to the digestive tract which concurs with research reported by Greene et al. (2, 3). Potassium infused into the ruminal cannula decreased ($P<0.05$) Ca retention linearly due to a linear increase ($P<0.05$) in urinary Ca excretion and a linear decrease in Ca intake.

Serum mineral concentrations of lambs are shown in Table 5. Although not significantly different, serum Mg concentrations were 4 percent higher with monensin in the diet. Kirk et al. (4) also reported a non-significant increase in serum Mg concentrations of 5 percent in lambs fed monensin. Monensin did not affect serum concentrations of K and Ca. Serum Mg decreased ($P<0.05$) 8.8 and 14.4 percent when 7.6 and 31.6 g of K were infused into the rumen. Greene et al. (2, 3) reported a similar reduction in serum Mg when lambs were fed elevated concentrations of K. Serum K concentration increased linearly from 21.5 to 26.3 mg/dl when increasing quantities of K were infused into the rumen.

Lambs fed monensin had greater ($P<0.05$) concentrations of propionate and lower ($P<0.05$) concentrations of acetate in ruminal fluid compared to lambs fed the basal diet. This resulted in a more favorable acetate:propionate ratio when monensin was fed (Table 6). There was a significant interaction between monensin and K level for acetate and propionate

Table 5. Serum mineral concentrations in lambs fed monensin and ruminally infused with three levels of potassium

Item	Monensin level, mg/kg			Level of infused potassium, g/day			SE
	0	20	SE	0	7.6	31.6	
	-----mg/dl-----						
Magnesium ^a	2.45	2.55	0.10	2.70	2.46	2.31	0.12
Potassium ^a	23.3	23.9	1.24	21.5	23.7	26.3	1.52
Sodium ^b	463	533	29.30	511	500	491	35.90
Calcium	9.29	9.56	0.24	9.56	9.38	9.36	0.29

^aLinear effect of potassium (P<0.05).

^bAffected by monensin (P<0.05).

Table 6. Acetate, propionate and butyrate (molar %) and acetate:propionate ratio in ruminal fluid of lambs fed monensin and ruminally infused with three levels of potassium

Monensin level, mg/kg	0			20			SE
	0	7.6	31.6	0	7.6	31.6	
Acetate ^a	53.9 ^b	56.6 ^c	65.4 ^d	47.9 ^b	53.4 ^{bc}	48.0 ^b	1.57
Propionate ^a	30.5 ^{bc}	34.3 ^{cd}	24.1 ^b	42.2 ^{de}	34.0 ^{cd}	42.5 ^e	1.84
Butyrate	12.9	7.2	7.9	8.0	10.5	6.8	1.07
Acetate: Propionate ratio ^a	1.82 ^c	1.77 ^c	2.79 ^d	1.16 ^b	1.63 ^{bc}	1.19 ^b	0.15

^aMonensin × potassium interaction (P<0.05).

^{b,c,d,e}Means within the same row without a common superscript differ (P<0.05).

(molar percent), and the acetate:propionate ratio. The interaction between monensin and K level for acetate appears to be related to an increase in acetate when 31.6 g K/day was infused in lambs receiving the control diet but not those receiving monensin. Additionally the acetate:propionate ratio was lower in lambs fed monensin and infused with 31.6 g K/day in comparison to lambs fed the basal diet and infused with K. This response indicates that monensin may be more effective in increasing the efficiency of rumen fermentation when larger quantities of K are present.

In conclusion, increased Mg absorption in lambs fed monensin is probably an indirect response related to monensin's direct interaction with K in the rumen, since the proposed ruminal absorption mechanism of Mg (6) is based upon the Na-K-ATP-ase activity. Additionally, monensin may be more effective in enhancing rumen fermentation when larger quantities of K are present. Additional research is needed to further elucidate the involvement of altered mineral metabolism in animals fed ionophores.

Literature Cited

- Charles, O. W. and S. Duke. 1981. Growth rate response of monensin-fed broiler chick to magnesium-potassium sulfate. *Poul. Sci.* 60:1596.
- Greene, L. W., J. P. Fontenot, and K. E. Webb, Jr. 1983. Effect of dietary potassium on absorption of magnesium and other macroelements in sheep fed different levels of magnesium. *J. Anim. Sci.* 56:1208.
- Greene, L. W., K. E. Webb, Jr., and J. P. Fontenot. 1983. Effect of potassium level on site of absorption of magnesium and other macroelements in sheep. *J. Anim. Sci.* 56:1214.
- Kirk, D. J., L. W. Greene, G. T. Schelling, and F. M. Byers. 1985. Effects of monensin on Mg, Ca, P, and Zn metabolism and tissue concentrations in lambs. *J. Anim. Sci.* 60:1485.
- Kirk, D. J., L. W. Greene, G. T. Schelling, and F. M. Byers. 1985. Effects of monensin on monovalent ion metabolism and tissue concentration in lambs. *J. Anim. Sci.* 60:1479.
- Martens, H., J. Harmeyer, and H. Michael. 1978. Magnesium transport by isolated rumen epithelium of sheep. *Res. Vet. Sci.* 24:161.
- Newton, G. L., J. P. Fontenot, R. E. Tucker, and C. E. Polan. 1972. Effects of high dietary potassium intake on the metabolism of magnesium by sheep. *J. Anim. Sci.* 35:440.
- NRC. 1975. Nutrient requirements of domestic animals, no. 5. Nutrient requirements of sheep. (Fifth revised ed.). National Academy of Sciences. National Research Council, Washington, D.C.
- SAS. 1979. SAS user's guide. Statistical Analysis System Institute, Cary, NC.
- Smith, J. B. and E. Rozengurt. 1978. Serum stimulates the Na, K-pump in quiescent fibroblasts by increasing Na entry. *Proc. Natl. Acad. Sci. USA* 75:5560.
- Starnes, S. R., J. W. Spears, M. A. Froetschel and W. J. Croon, Jr. 1984. Influence of monensin and lasalocid on mineral metabolism and ruminal urease activity in steers. *J. Nutr.* 114:51.

Variability of Staple Length in Short-Shorn Wools

C.J. Lupton, M. Shelton, and J. Cox

Summary

Length parameters were determined on the fleeces of 133 Rambouillet ewes. The sheep were divided into four groups and sheared at intervals of 4.5, 6, 7, and 11 months by three shearers possessing varying degrees of skill. It is shown that the influence of the skill of the shearers on mean staple length is negligible except in the critical case of the shortest (4.5 month) wool. Length variability within fleeces tends to be greater than length variability between fleeces for 4.5-, 6-, and 7-month growth periods while the reverse is indicated for 11-month wools. Although the 4.5-month wool would probably be an acceptable raw material for the short-staple textile industry, the 6- and 7-month fleeces from this flock appear to contain an excessive amount of wool greater than 2 inches in length which is considered the upper limit for the short-staple system.

Further research is being conducted to quantify mean fiber length and variability in the scoured fleeces.

Introduction

On June 30, 1983, the U.S. Department of Commerce Census recorded 758,807 worsted and woolen spindles operating in the United States. This represented a 19.2 percent reduction compared to the number reported 5 years earlier. In the same time frame, the number of cotton system (short-staple) ring spindles fell from 17,182,204 to 14,760,961. These reduced numbers of spindles reflect a general decline in the U.S. textile industry. However, the bare statistics tend to exaggerate the decline since they do not indicate the increased efficiency of many of the remaining spinning units. The fact remains that the traditional domestic outlets for wool and mohair are decreasing in number. In order to maintain or increase their current market share, wool and mohair might be adapted to non-traditional processing technologies. Research and promotional agencies have joined forces in recent years to create and establish acceptable products composed of wool, mohair, wool/cotton, and wool/polyester yarns spun on the cotton system. It is anticipated that acceptance of these products by the (relatively) massive short-staple industry would result in both improved prices and demand for animal fibers and thus greater profitability for the producer.

To date, three separate approaches have been used to introduce wool fibers into the short-staple system. Two methods have involved traditional processing (scouring, carding, drawing and combing) through to the top stage. Subsequently, the top has either been cut

into 1½- to 2-inch lengths or stretch-broken in order to produce wool of suitable length. Stretch-breaking usually results in a product of higher length uniformity than cutting (1). Unfortunately, stretch-breaking is slower and more expensive than cutting. The cost of producing these semi-processed "raw materials" for the cotton system is quite high. Nevertheless, a small segment of the industry has been willing to pay the price in order to manufacture products with unique character using this system of

A third approach at introducing wool into the cotton system has been through the provision of short-shorn (5-6 month) wool. This would appear to be the most logical method since scouring would be the only manufacturing process required to convert the grease wool into the raw material for a short-staple textile mill. A previous attempt (2) to provide such a product resulted in a batch of wool having excessive variation in length. Consequently, research was initiated to quantify this length variability, determine the source and, if possible, identify methods to eliminate the problem. In this manner, a third, potentially less expensive source of short wool could be made available to the short-staple industry.

In the recent past, several commercial ventures have attempted to provide short-shorn wool directly to the short-staple industry. These companies have met with minimal success although factors other than length variability (e.g., the presence of an excessive amount of vegetable material or number of colored fibers) have resulted in a lack of general acceptance. Further, it is noted that producers might require a substantially higher price for their wool to compensate for shearing twice a year. Presumably, this would not apply to the shearing of short lambswool in feedlot situations or to those areas of the state which have traditionally sheared twice a year.

Finally, it is noted that one of the more critical values in short-staple processing is maximum fiber length. It is claimed (1) that modern, short-staple drawframes can satisfactorily process synthetic staple with a fiber length up to about 2.5 inches. For the more disperse fiber-length distribution of wool, no more than 5 percent of the fibers should exceed this length. More than a decade of precessing short wool on traditional cotton equipment has resulted in a more conservative recommendation, i.e. no more than 3 percent of the fibers should be over 2 inches (3).

Experimental Procedure

A uniform flock (133 sheep) of 3- to 4-year-old Rambouillet ewes was identified and maintained under range conditions on the H.D. Winters Ranch at Brady, Texas. The sheep were shorn at the beginning of the study. Subsequently, segments of the flock were shorn at 4.5-, 6-, 7-, and 11-month intervals. Shearing was achieved on each occasion by three shearers having different levels of skill. The mean staple length of each unskirted fleece was measured in accordance with ASTM Test Method D-1234 using 50 randomly pulled staples per fleece.

Table 1. Mean staple length and variability of 4.5-month fleeces

Skill level of shearer	High			Medium			Low		
	Animal I.D.	Mean staple length (in)	C.V. ^a (%)	Animal I.D.	Mean staple length (in)	C.V. (%)	Animal I.D.	Mean staple length (in)	C.V. (%)
	2387	1.67	8.98	2457	1.24	12.90	2807	1.51	7.95
	2458	1.67	7.78	2495	1.76	8.52	2862	1.55	9.68
	2794	1.56	8.97	3143	1.51	10.60	2967	1.34	12.69
	2801	1.53	9.15	3197	1.57	7.64	3135	1.45	10.34
	2964	1.54	8.44	3418	1.53	7.19	3185	1.56	7.69
	3150	1.62	8.64	3473	1.63	7.98	3321	1.59	9.43
	3233	1.59	9.43	3474	1.43	10.49	3374	1.25	17.60
	3369	1.53	7.19	3509	1.67	8.98	3400	1.53	10.46
	3384	1.65	8.48	3510	1.52	8.55	3453	1.57	8.92
	3446	1.51	12.58	3605	1.49	6.04	3493	1.56	8.97
	3465	1.62	9.88						
	3482	1.60	7.50						
	3496	1.47	9.52						
	3511	1.47	9.52						
	3521	1.83	8.20						
	3548	1.61	11.18						
	3559	1.80	8.33						
	3576	1.59	10.06						
	3584	1.53	9.15						
	3633	1.63	8.59						
	—	1.65	8.48						
Group means		1.603	9.050		1.535	8.889		1.491	10.373
CV% of means		5.773			9.214			7.53	

^aCV = Coefficient of variation.

Table 2. Mean staple length and variability of 6-month fleeces

Skill level of shearer	High			Medium			Low		
	Animal I.D.	Mean staple length (in)	C.V. (%)	Animal I.D.	Mean staple length (in)	C.V. (%)	Animal I.D.	Mean staple length (in)	C.V. (%)
	2791	2.10	8.10	2491	2.10	10.95	2768	1.97	6.09
	2965	2.07	7.25	2842	1.87	10.70	2891	1.92	10.42
	2977	2.12	7.55	3121	1.70	11.76	3129	1.64	12.20
	3061	1.84	9.24	3123	2.12	7.55	3171	2.01	5.47
	3127	1.96	8.16	3178	1.84	8.15	3179	2.13	9.39
	3145	1.95	7.18	3217	2.06	7.77	3195	2.24	9.38
	3156	2.14	7.48	3269	1.74	11.49	3242	2.12	9.43
	3347	1.99	9.05	3335	2.09	9.57	3387	1.89	7.94
	3433	2.05	10.24	3339	1.96	8.16	3413	2.02	7.43
	3563	1.96	8.16	—	2.13	6.57	3637	1.91	11.52
Group means		2.018	8.241		1.961	9.267		1.985	8.927
CV% of means		4.659			8.318			8.299	

Results and Discussion

Tables 1-4 contain the staple length data for individual fleeces which were shorn at intervals of 4.5, 6, 7, and 11 months, respectively. A broad spread of mean staple lengths and coefficients of variation is evident in each of the 12 categories. In the cases of the short-shorn wools (4.5, 6, and 7 months) variation in mean staple length between fleeces is smaller than the variation in staple length within a fleece as indicated by the

fact that the coefficients of variation of the means of mean staple length between fleeces in a particular growth/shearer group are invariably (one exception) smaller than the means of the coefficients of variation of staple length of individual fleeces for the same group. For the longer, 11-month wool, this situation appears to be reversed (again, one exception). The experimental design and mean staple length data are summarized in Table 5. The skill of the shearer did not

Table 3. Mean staple length and variability of 7-month fleeces

Skill level of shearer	High			Medium			Low		
	Animal I.D.	Mean staple length (in)	C.V. (%)	Animal I.D.	Mean staple length (in)	C.V. (%)	Animal I.D.	Mean staple length (in)	C.V. (%)
	2496	2.15	6.98	2469	2.39	7.53	2389	2.19	6.85
	2875	2.12	6.13	2600	2.15	7.91	2861	2.32	8.70
	3209	2.46	8.54	2851	2.18	8.72	2880	2.32	9.48
	3318	2.22	8.11	3115	2.10	7.62	3268	2.41	7.47
	3322	2.18	8.26	3174	2.26	8.85	3282	2.21	9.50
	3337	2.38	11.76	3208	2.60	9.62	3434	2.15	7.91
	3456	2.22	9.01	3270	2.14	7.94	3435	2.42	9.92
	3556	2.53	11.46	3283	2.35	8.09	3447	2.00	7.50
	3575	2.45	9.80	3381	2.13	8.45	3488	2.05	8.29
	3608	2.07	5.31	3451	2.27	10.13	3571	2.17	7.37
Group means		2.278	8.536		2.257	8.486		2.224	8.299
CV% of means		7.132			6.864			6.388	

Table 4. Mean staple length and variability of 11-month fleeces

Skill level of shearer	High			Medium			Low		
	Animal I.D.	Mean staple length (in)	C.V. (%)	Animal I.D.	Mean staple length (in)	C.V. (%)	Animal I.D.	Mean staple length (in)	C.V. (%)
	2476	3.10	6.13	2771	2.92	6.16	1	3.13	5.43
	2784	2.89	7.96	2871	3.09	5.83	2	3.18	7.24
	2792	2.90	5.52	3142	2.97	3.70	2753	2.93	11.26
	2860	3.26	7.36	3160	3.35	11.64	2777	2.50	7.20
	2866	2.95	4.75	3214	3.40	7.06	3062	3.34	8.08
	3126	3.60	6.39	3416	3.36	8.93	3128	2.95	6.78
	3184	3.29	6.99	3423	3.03	4.62	3250	3.50	9.71
	3361	3.37	8.30	3499	2.92	12.67	3255	3.12	7.37
	3454	3.42	7.89	3508	3.02	5.96	3443	2.91	7.24
	3535	3.11	5.79	3628	2.82	9.57	3452	3.09	6.47
				3643	3.30	7.88	3581	3.15	7.62
Group means		3.189	6.708		3.107	7.638		3.073	7.673
CV% of means		7.497			6.682			8.406	

Table 5. Experimental design and group mean staple length data

Wool growth period (months)	4.5			6			7			11			
	Shearer skill level	High	Medium	Low	High	Medium	Low	High	Medium	Low	High	Medium	Low
Number of sheep sheared		21	10	10	10	10	10	10	10	10	10	11	11
Mean staple length (in)*		1.603 ^a	1.535 ^{ab}	1.491 ^b	2.018 ^c	1.961 ^c	1.985 ^c	2.278 ^d	2.257 ^d	2.224 ^d	3.189 ^e	3.107 ^e	3.073 ^e
Coefficient of variation of mean staple length (%)		9.050	8.889	10.373	8.241	9.267	8.927	8.536	8.486	8.299	6.708	7.638	7.673

*Means not sharing common superscripts differ ($P < .05$).

Table 6. Proportion of staples greater than 1.875 and 2.125 inches

Wool growth period (months)	4.5		6		7	
Skill level of shearer	Staples \geq 1.875 inches (%)	Staples \geq 2.125 inches (%)	Staples \geq 1.875 inches (%)	Staples \geq 2.125 inches (%)	Staples \geq 1.875 inches (%)	Staples \geq 2.125 inches (%)
High	4.8	0.6	80.6	24.6	99.8	67.4
Medium	3.0	0	73.0	22.2	99.4	65.0
Low	1.2	0	67.0	19.8	97.2	60.8
Mean values	3.0	0.2	73.5	22.2	98.8	64.4

Table 7. Proportion of staples greater than 2.375 and 2.625 inches

Wool growth period (months)	4.5		6		7	
Skill level of shearer	Staples \geq 2.375 inches (%)	Staples \geq 2.625 inches (%)	Staples \geq 2.375 inches (%)	Staples \geq 2.625 inches (%)	Staples \geq 2.375 inches (%)	Staples \geq 2.625 inches (%)
High	0	0	2.6	0	29.8	9.8
Medium	0	0	3.8	0.6	29.8	5.8
Low	0	0	5.0	0.6	26.2	4.2
Mean values	0	0	3.8	0.4	28.6	6.6

cause a measurable effect in the 6-, 7-, or 11-month fleeces. In the case of the shortest wool, the shearer with the highest level of skill produced fibers having a mean staple length significantly longer than those produced by the shearer with the lower skill level. Thus, as expected, the quality of shearing is particularly important for retaining staple length in the case of short-shorn wool. Despite the lack of statistical significance, it is interesting to note that the mean staple lengths produced by the highly skilled shearer have the highest value in each category.

Table 6 shows the proportion of measured staples having lengths greater than 1.875 and 2.125 inches. It would appear that in this respect, the 4.5-month wool would be acceptable to the conventional, short-staple industry but that the 6- and 7-month wools from this particular flock contain too many, excessively long staples. On the other hand, if a mill possessed modern drawframes and spinning units capable of handling fibers up to 2.5 inches long, the 6-month wool would also be acceptable (Table 7). This conclusion is critical since shearing at 4.5- and 7.5-month intervals would only result in one clip suitable for the short staple industry, whereas shearing at 6 monthly intervals would result in two.

Mean staple length was the primary variable measured in the study. Within a single flock, mean staple length is highly correlated with mean fiber length (4).

Nevertheless, it is planned to expand the study to include measurements of mean fiber length on scoured fleeces. It is likely that mean fiber length measurements are more sensitive to the three types of variability (shearer, within fleece, between animals) being studied. In any event, more data will be generated which will be of value to producers and the textile industry.

Literature Cited

1. Eley, J.R., B.V. Harrowfield, D.E. Henshaw, and G.A. Robinson. 1980. Stretch-breaking and cutting of wool for the short-staple system. Proceedings, 6th Quinquennial International Wool Textile Research Conference, Pretoria. Volume 111, 349.
2. Lupton, C.J. 1980. Wool processing on the cotton system: a comparison between cut-top wool and sixth-month shorn wool in a blend with polyester. Textile Research Journal 50, 2, 119.
3. Arthur, H.E. Textile Research Center, Texas Tech University. Personal communication.
4. Hunter, L. 1980. The effects of wool fibre properties on processing performance and yarn and fabric properties. Proceedings, 6th Quinquennial International Wool Textile Research Conference, Pretoria. Vol. 1, 133.

Some Fleece and Fiber Characteristics of Texas Karakul Sheep

C.J. Lupton and M. Shelton

In 1983, a study (1) was completed in which the cutability and palatability characteristics of the Karakul fat-tailed breed of sheep were investigated and compared to Rambouillet and black-face crossbred sheep. Since that time, a small flock of Karakul sheep has been maintained at San Angelo and a quantity (865 lb) of carpet-type, heavily medullated wool from these animals was accrued. This grease wool was scoured using a Petrie-McNaught Model Scouring Train. The multicolored wool yielded 58.1 percent, with the scoured wool containing 0.6 percent residual grease and 1.3 percent vegetable matter. The mean fiber diameter of the scoured product was 29.2 microns (μm) with a standard deviation of 11.15 μm . Six distinct colors of Karakul wool were identified and subsequent measurement of mean fiber diameter revealed significant differences between both the means

Table 1. Fiber diameters of six colors of Karakul wool

Color of Karakul	Mean fiber diameter* (μm)	Standard deviation of mean fiber diameter (μm)
White	27.4 ^a	9.7
Off-white	32.2 ^b	13.9
Gray	25.8 ^c	8.9
Light brown	24.4 ^d	9.3
Dark brown	26.3 ^c	11.3
Black	32.2 ^b	12.8

*Means not sharing common superscripts differ ($P < .05$)

and variabilities of the means of the various colors (Table 1). Quantification of medullation was hampered by the presence of pigment in the cases of the colored wools. It is possible that differences in medullation contributed to the observed differences in mean diameter.

Literature Cited

1. Edwards, R.L., D.D. Crenwelge, J.W. Savell, M. Shelton, and G.C. Smith 1983. Cutability and palatability of Rambouillet, blackface-crossbred and Karakul lambs. P. 119 in *Tex. Agri. Expt. Sta. CPR-4171*.

Variation in Wool Fiber Diameter From Tip to Base Among Rambouillet Rams on Performance Test

C.J. Lupton and M. Shelton

Summary

The mean fiber diameters of wool samples taken from rams on the TAES Annual Ram Performance Test increase from the tip to the base of the fibers. Most of the enlargement occurs by the middle of the growth period. Quantification of this phenomenon may have repercussions on the methods used to determine fiber diameter parameters in future tests. The techniques developed and used in this study may be of interest for evaluating the effect of nutrition and other management factors on wool properties.

Introduction

Mean fiber diameter is an important property determining the value of wool. Consequently, it is one of several fiber variables that have been routinely and objectively measured in ram performance tests. Fiber diameter is not used in either of the indices that are used to rank the rams in the Sonora ram test, but an

independent culling for fiber fineness is suggested. Individual breeders may set this level at whatever point they wish. In the Registry of Merit (ROM) program of the American Rambouillet Sheep Breeders Association, these values are: not coarser than 24.94 microns (μm) (i.e., 60's grade) on the side nor 27.84 μm (i.e., 56's grade) on the britch. The rams become coarser under test conditions, and these values were adjudged from prior research (1) to result in 64's grade or finer wool when the animals or their offspring are maintained under range conditions.

It is expected that the fibers being produced become coarser with the increase in weight of rams on test and variation in diameter along the staple could become a factor in making this determination. A new technique for subsampling side and britch samples has been developed for use with the Peyer FDA200 Fiber Fineness Measuring System.¹ This technique does not involve the longitudinal randomization of fibers during subsampling and thus allows differentiation between the tip, middle, and base sections of the fibers.

Experimental Procedure

In order to quantify the variation in wool fiber fineness from tip to base during a 100-day growing period, 31 animals in the 1986 performance test were selected at random. Side samples were taken in the

¹Peyer FDA200, a product of Peyer Electronics, Wollerau, Switzerland.

normal manner 100 days into the test period at which time the average staple lengths varied from 1-1 1/2 inches. Subsequently, staples were subsampled using a two-bladed guillotine (Peyer Fiber Cutter TC200) resulting in fiber snippets having a length of approximately 1.8 mm. Subsampling was conducted first in the middle of a particular staple then at the center of the cut section containing the tip and finally in the middle of the section containing the base of the fiber (Figure 1). The individual sets of snippets were then scoured (using a microscouring technique), dried, and measured using the Peyer FDA200 Fiber Fineness Measuring System. Two thousand fibers were measured in each case. The instrument was also used to calculate and record mean diameter, standard deviation and coefficient of variation of mean diameter.

Results and Discussion

Mean fiber diameters and standard deviations for the tip, middle, and base sections of side samples taken from 31 rams are presented in Table 1. Similar data for the middle section of britch samples are also documented for comparison. With four exceptions, the trend is for fiber diameter to increase progressively from tip to middle to base. The magnitude of this increase is quite variable between animals ranging from a high of 5.46(μ)m (ram number 4) to a low of 0.47(μ)m (ram number 25). For the small group tested in this manner, the coarsening effect is perhaps best quantified with reference to the grand means of fiber diameter in the three sections under consideration. It is shown that, on the average, the base sections are 0.58(μ)m coarser than the middle which in turn are 1.19(μ)m coarser than the tip sections. Differences between the britch and side measurements and between the tip and other side measures were statistically

significant. Variability of mean fiber diameter is approximately constant in all four sections measured. As expected, the middle sections of the britch samples are invariably coarser than the same sections of the side sample (2.26 μ m on average). The tendency for the animals to have a coarser britch has been established previously (2).

The realization that fiber diameters vary along the length of the staple can be viewed positively or negatively. The documentation that these differences occur and the development of a method of measuring these variations would appear to present a means of studying the effect of nutrition or other management factors on fiber production. However, in the case of the ram tests, there is a problem of which measurement to use. In the current year's test, the measurements made on the mid-section were used in reporting. The mid-section value should be somewhat coarser than the mean of the three, and this may be a partial explanation for the tendency for rams to be coarse in the 1985-86 test. It may be desirable to consider this in future tests. However, measuring all the rams at the same point in the staple should improve the basis for comparison between animals, and this might only indicate a slight adjustment in the standard such as the maximum acceptable fiber diameters.

Literature Cited

1. Bassett, J.W., B.F. Craddock, M. Shelton, and C.A. Taylor. 1977. Fiber quality of performance test rams compared with their offspring. Tex. Agri. Expt. Sta. PR-3469.
2. Willingham, T., M. Shelton, and J.W. Bassett. 1983. Fleece quality as affected by britch removal. SIDP Research Digest 1:26.

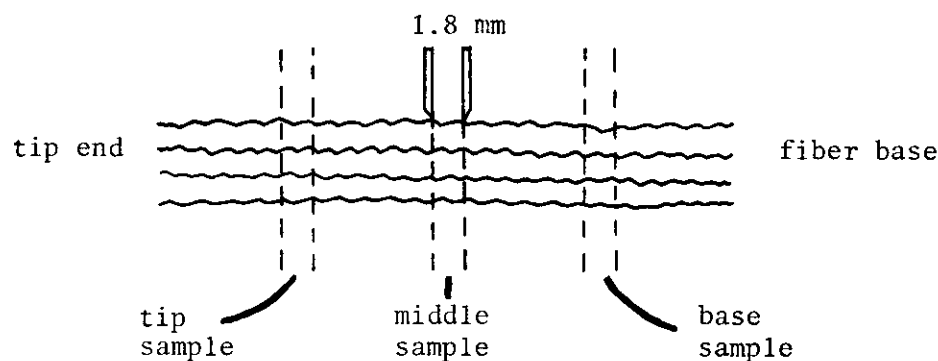

Figure 1. Sampling of wool staple using a double bladed guillotine (approximately 2x actual size)

Table 1. Mean diameters and standard deviations along the length of side samples and at the mid-section of britch samples

RAM I.D.	Side sample				Britch sample			
	Tip section		Middle section		Base section		Middle section	
	Mean diameter (μm)	Standard deviation (μm)	Mean diameter (μm)	Standard deviation (μm)	Mean diameter (μm)	Standard deviation (μm)	Mean diameter (μm)	Standard deviation (μm)
1	20.49	4.64	23.78	4.70	24.20	4.61	26.28	5.43
2	18.84	3.72	21.25	3.53	21.27	3.69	25.01	4.75
3	20.40	4.86	22.13	4.44	23.30	5.32	25.54	5.46
4	20.24	5.10	24.88	5.12	25.70	5.87	26.13	5.65
5	20.73	4.54	21.93	5.02	22.73	5.79	22.34	4.76
6	23.49	5.35	24.94	5.03	25.11	5.77	26.23	5.09
7a	20.76	4.68	20.55	4.37	21.36	5.28	23.99	5.20
8	21.61	5.48	23.71	6.78	24.26	7.05	26.48	6.48
9	19.95	4.67	21.40	4.74	22.26	4.65	24.11	5.24
10	23.02	5.74	24.03	5.78	24.73	6.55	26.02	5.83
11	19.81	4.25	20.63	4.15	21.06	4.27	23.59	4.72
12	21.16	5.74	22.00	4.95	22.68	6.74	24.55	5.58
13	20.93	4.10	22.27	4.37	22.43	4.42	25.53	5.24
14	21.19	5.19	22.07	5.44	22.73	5.86	24.84	6.03
15	22.43	6.85	23.78	5.99	25.02	6.13	27.33	5.52
16	21.90	4.63	22.28	4.45	22.85	4.72	24.56	5.33
17	22.16	5.65	22.58	5.44	23.32	5.97	23.29	4.75
18	21.81	4.65	22.34	4.64	22.98	4.81	25.89	6.36
19	22.43	4.67	23.56	4.89	24.11	5.11	24.85	4.39
20	21.66	4.74	23.09	4.73	24.11	6.08	23.81	4.74
21	20.75	4.00	22.01	4.20	22.75	4.37	24.47	4.84
22	20.70	4.64	21.24	4.55	21.77	4.70	23.35	4.75
23	20.16	3.80	21.58	4.54	21.92	4.99	23.73	5.42
24	20.46	3.94	22.33	4.83	23.53	6.64	23.23	4.49
25	24.22	5.93	24.33	5.07	24.69	5.70	25.79	4.99
26	20.92	4.15	21.27	4.52	21.42	4.29	23.36	5.22
27	25.66	5.98	26.85	5.43	26.87	5.73	29.43	7.47
28a	26.34	6.42	25.99	6.42	26.84	6.67	29.11	6.76
29	21.29	3.80	22.14	4.50	22.34	4.79	26.02	6.49
30a	23.23	6.51	23.05	5.84	23.94	7.12	25.03	5.63
31a	19.90	4.90	21.47	4.56	21.38	5.36	21.61	4.19
Grand means	21.57	4.95	22.76	4.94	23.34	5.45	25.02	5.38

a = exception to the "progressive coarsening rule".

Kemp Fiber Measurements

J. W. Bassett

Summary

Mohair samples were obtained from different body locations on Angora goats in September and in January. Kemp counts were obtained using micro-projection methods and counting 1,000 fibers. Body areas showing the greatest kemp counts were rump, britch, and adjacent to the tail. Mid-neck, side, and withers had the lowest kemp counts. Average kemp counts on those animals which were sampled in both September and January showed lower kemp counts in January. Seasons and/or shearing may be factors influencing kemp count.

Introduction

Medullated fibers are those which have large air-filled cells in the center of the fiber rather than the spindle-shaped, protein corticle cells which constitute the bulk of the fiber and give it strength, elasticity, resilience and elongation. Medullated fibers in which the hollow area is less than 65 percent of the fiber diameter are termed "med" fibers. Fibers with a hollow area of 65 percent or more are termed "kemp" fibers. Kemp fibers are found in both mohair and wool but are more common in mohair. They are considered a very undesirable type of fiber, although the degree to which they can be tolerated varies greatly with the type and color of fabric to be constructed. The large hollow portion causes the fiber to be less strong with less extensibility and a greater amount of fiber breakage occurs during processing. Dyeing presents the biggest problem, particularly for dark colors. There are many less corticle cells to absorb dye and the large hollow area gives a different light refraction so that the kemp fibers appear a much lighter shade than the rest of the fibers.

Texas mohair is frequently criticized for its kemp content. A study of Texas mohair in 1981 (1) indicated that there are differences in kemp content among flocks and that there are possible differences between seasons. Angora goats are normally shorn at 6-month intervals, in the spring and in the fall. The extent to which kemp is genetically controlled or environmentally influenced has not been determined. A great deal more effort is needed.

Experimental Procedure

Mohair samples were obtained from 20 Angora goats at the Joe David Ross Ranch, Sonora on September 23, 1982. These represented primarily males of mixed ages, but there were some females and one late, out-of-season kid goat. Samples were clipped from the following listed body areas using a ShearMaster: top of

neck; mid-neck; withers; mid-side; rump; britch; adjacent to tail.

A second set of mohair samples was obtained from the Ross Ranch on January 5, 1983. Sixteen animals were sampled, nine of which were in the group originally sampled in September. The same body areas were sampled with the exception that a mid-back rather than top of neck area was sampled.

Samples were taken to the Wool and Mohair Laboratory, Kleberg Center, for counting kemp fibers. The micro-projection method (ASTM Standard Method D-2968) was utilized and approximately 1,000 fibers were counted for each sample.

Results and Discussion

The results of kemp measurements by body area and time period are shown in Table 1. In September the mid-neck and mid-side samples showed the lowest kemp count for both mean value and range values. All body areas show at least one animal with no kemp count, but there was only one animal which showed no kemp on all body areas. The rump and britch areas were the locations showing the highest kemp percentages, both mean values and range.

At the second sampling period, considering all animals sampled, the mid-side area was lowest in kemp, both mean and range, with little difference in neck, withers, and back. The rump, britch, and tail areas had the greatest amount of kemp with little difference between these three. Kemp percentages were lower in these samples than in the earlier samples with the exception of the mid-neck area, which was fairly low at both periods.

A comparison of kemp percentages looking only at the animals which were sampled at both times is shown in Table 2. These data are similar to that for all animals in that the mid-neck and mid-side show the lowest levels of kemp, while the rump, britch and adjacent to the tail have the highest kemp content. Differences between time periods show consistently lower levels of kemp in January as compared to September.

The kemp percentages for the late, out-of-season kid are given in Table 3. While these show very high levels of kemp as compared to the adult animals and a large decrease between sampling periods, the body

Table 1. Kemp content by period and body area

Body area	September 1982			January 1983		
	Kemp			Kemp		
	No. animals	%	Range	No. animals	%	Range
Top of neck	18	0.74	0-2.30	—	—	—
Neck	19	0.25	0-0.89	15	0.30	0-1.15
Withers	19	0.64	0-2.71	15	0.20	0-0.86
Back	—	—	—	15	0.34	0-1.20
Side	19	0.36	0-1.74	14	0.14	0-0.50
Rump	19	1.39	0-3.74	15	0.60	0-1.47
Britch	18	1.12	0-4.18	15	0.58	0-2.52
Tail	19	0.82	0-1.96	15	0.62	0-2.29

Table 2. Kemp count on same animals

Body area	September 1982	January 1983
	Kemp, %	Kemp, %
Neck	0.23	0.16
Withers	0.65	0.23
Side	0.25	0.20
Rump	1.47	0.76
Britch	1.09	0.80
Tail	1.09	0.80

Table 3. Kemp content, kid goat

Body area	September 1982	January 1983
	Kemp, %	Kemp, %
Top of neck	5.70	—
Neck	14.40	1.20
Withers	6.21	1.18
Back	—	0.50
Side	6.12	0.20
Rump	5.48	1.19
Britch	8.00	1.20
Tail	6.80	3.24

area differences are not in the same order as the older animals, particularly in September. These data are from only one very young animal, it must be noted.

The data presented indicate that time of sampling or observing and/or body area considered may need to be evaluated. The low levels of kemp found in the mid-neck and mid-side would indicate that these areas are probably not desirable for evaluating kemp content. These are two of the areas that are sampled for fiber diameter measurements for animals on the Angora goat performance test program and could be used for kemp determination. The britch area sample might be more accurate for evaluating kemp content.

The difference in kemp levels between September and January needs to be considered from two standpoints. The first samples were taken 1-2 months after shearing with the second samples taken before the next shearing. It is not evident as to whether the decreased kemp levels are associated with seasonal influences or with shearing. It is known that season has an influence on fiber length and diameter and it is possible that kemp is also affected. Work in New Zealand with wool indicated that shearing stimulated an increase in medullation, but this has not been previously investigated in mohair.

Literature Cited

1. Stobart, R. H. and J. W. Bassett. 1981. Objective measurements of Texas mohair. *Tex. Agri. Expt. Sta. PR-3905*.

Acknowledgements

This research was funded in part by the Mohair Council of America, San Angelo, Texas and by the Natural Fibers and Food Protein Commission of Texas, Dallas.

PR-4403

Review: Genetics and Management of Kemp in Mohair

E. Tiffany-Castiglioni

Summary

Published literature concerning the problem of kemp in mohair is reviewed in order to identify areas of research with high potential for managing or eliminating the problem. Characteristics of the hair fibers and follicles of Angora goats are described, including definitions of kemp and other fiber types, methods currently used to measure kemp levels, and development of follicles and fibers. Possible applications of biochemically induced shedding for harvesting kemp-free fleece are mentioned. The genetics of kemp and related fiber traits is discussed, including heritability, mode of inheritance, phenotypic correlations between kemp content of the fleece and other traits, and genotypic correlations with other traits. Environmental factors, such as season, sex, age, and nutrition, that may influence kemp levels are discussed. Finally, the brief literature on management of kemp levels in Angora flocks of major mohair producing countries is reviewed. Recommendations are made for specific studies that are needed to establish breeding and management programs for reducing kemp levels in mohair fleece. Genetic studies with large samples are needed to obtain heritability estimates, as well as genotypic correlations and phenotypic correlations between kemp and certain fleece and skin characteristics. Also, histochemical and biochemical studies are needed to identify active and resting stages of hair follicles, particularly the kemp-producing primary follicles.

Introduction

The occurrence in Angora goats of an undesirable fiber type known as kemp has been studied sporadically since the 1920's with the goal of reducing or eliminating its presence in the fleece. No scientific review of the literature pertaining to kemp in mohair has appeared, and such a review can be used in identifying areas of research with high potential for managing or eliminating the problem. Kemp production by Angora goats may conceivably be reduced either by genetic selection or by environmental modifications. A successful genetic approach requires that the trait be inherited and that, for practical application, it be accurately measured in young animals before they are selected for breeding. An environmental approach requires that external factors (such as nutrition or drug treatment) affect kemp production, that these effects can be measured, and that the environment can be modified to reduce kemp levels. Many traits are affected both genetically and environ-

mentally, and kemp may be among them. In addition, a trait may be influenced by the hormonal differences found between males and females, between intact and castrated males, or between kids and adults. With appropriate methodology, the factors involved in kemp formation can be weighed individually and the most effective plan for kemp reduction devised.

Hair Fibers and Follicles in Angora Goats

Characteristics of kemp fibers. The mohair fleece consists of three fiber types: true mohair, kemp, and a heterotype (12,17). Kemp and heterotypic fibers (also called medullated fibers or gare) differ from true mohair in that they possess a hollow center or medulla of large air-filled cells. Both types of medullated fibers take up dye less readily than true mohair, are conspicuous in the final fabric, and are therefore a contaminant of pure mohair. Kemp fibers are brittle, non-elastic, chalky white in appearance, and oval in cross-section. In contrast, mohair fibers are lustrous, elastic, and round in cross-section. Kemp fibers have been reported to cause a loss in combing of up to 18 percent of the original weight of mohair (12), although this demerit is not emphasized by more recent studies. In kemp fibers the medulla is continuous except at the tip. The medulla may occupy up to 90 percent of the fiber cross-sectional area. In contrast, heterotypic fibers are coarse and medullated at the tip, but finer and nonmedullated at the base (17). The medulla is less prominent and may be discontinuous, thus presenting fewer problems than kemp to textile manufacturers.

In standard methods of measurement, kemp and heterotypic fibers are arbitrarily distinguished by the extent of medullation seen in cross sections of the fibers. The American Society for Testing Materials (2) defines kemp fibers as those fibers in which more than 65 percent of the fiber diameter is occupied by a medulla, whereas heterotypic (med) fibers have an area of medullation of less than 65 percent. In Australia fibers with a "broad medulla" are kemp, those with a continuous, relatively narrow medulla or a discontinuous medulla are two grades of gare, and those with no medulla are mohair (33). Descriptions of criteria for identifying kemp in South Africa and Turkey, two other mohair producers, could not be found in the literature. An additional difference between kemp and mohair is that kemp fibers are usually shorter, ranging from 15 to 73 mm; mohair locks range from 85 to 280 mm in length (12). The average fiber length for various grades of commercial mohair samples is between 30 and 46 mm for kemp and between 149 and 214 mm for mohair. Some differences are expected between these measurements and those of modern, improved flocks, but more recent data are not available. Because of their shortness, many kemp fibers can be removed during the combing process in manufacturing yarn. Kemp fibers are also slightly larger in diameter than mohair, but this factor does not affect the mean fiber fineness of the mature fleece (4).

Measurement of kemp levels. Four methods are currently in use to measure kemp in mohair. First, kemp is

most often determined by visual appraisal of animals to be used for breeding. The fleece is examined along the back and rump to evaluate the amount of kemp. However, no definitive standards exist to indicate acceptable or unacceptable levels. Second, the method of the American Society for Testing Materials (1, 2) for determining kemp content is to count kemp fibers and total fibers with a microprojector during the routine procedure in which fibers are measured for diameter. In this method, a fleece sample is sectioned near the base so that a cross section of all the fibers present is obtained. A random sample of these fiber fragments is analyzed, and kemp is expressed as a proportion of the total number of fiber fragments counted. The fiber count method is effective for fleece samples or samples at any stage of marketing or processing. Third, manufacturers of *top*, an intermediate stage of processing before the mohair is spun into yarn, determine kemp content by visually counting the number of kemp fibers per ½ ounce of mohair top. Fourth, kemp content is measured by immersing the hairs in benzene or a liquid having the same refractive index for light, which causes the mohair to be invisible and leaves the kemp visible. The number of kemp fibers per ½ ounce of sample is counted.

The region of the body sampled is critical to the determination of kemp content in the fleece. In a report in this volume by Bassett, kemp measurements were taken by the method of the American Society for Testing Materials from the neck, withers, side, rump, britch, and tail of nine breeding Texas Angora males and one kid. In general, kemp levels in the adults fell into two groups: high levels in rump, britch, and tail samples (e.g., 1.09-1.47 percent in autumn) and low levels in neck, withers, and side samples (e.g., 0.25-0.65 percent). The kid, however, had high levels in neck, withers, rump, and britch samples, but low levels on the back and side. These findings support an earlier study (7), which showed that in adults kemp levels were significantly greater on the britch than on other areas studied (neck, side, back, and belly). Stapleton (33) also mentions that the quantities of kemp are greater at the britch; therefore, samples should be taken from the high-kemp areas in assessing the kemp score of an animal.

Follicle and fiber development. Fibers in the Angora goat are produced by two types of follicles, primary and secondary. The histogenesis of follicles in the Angora goat was described by several investigators (4,8,20,21). The primary follicles are those that appear first and begin producing fibers early in fetal development. Secondary follicles occur in later stages of fetal development and may not begin producing fibers until after birth. The two types of follicles occur in bundles called follicle groups. Primary follicles are recognized histologically by their spatial position in the follicle group and their accessory structures. In the skin of sheep and goats each follicle group typically contains a triad of primary follicles, though occasionally two, four, or five primary follicles are present. The number of secondary follicles varies. In well bred

Angora goats, kemp and heterotypic fibers are produced by primary follicles and mohair by secondary follicles (21). In less improved flocks, gare is produced by secondary follicles (33). Kemp fibers are vestigial guard hairs and mohair fibers are the undercoat of the fleece (12).

Histological identification of primary and secondary follicles can be problematic, though not all authors discuss its possible pitfalls. Accessory structures to the primary follicle are a sudoriferous gland, a bifurcated smooth muscle (arrector pili) and a large lobulated sebaceous gland. Secondary follicles have only sebaceous glands, and even these may be absent. In order to identify these structures, tissue samples must be cut at a critical level where the follicle appendages indicate the difference between primary and secondary follicles (4). Furthermore, an absolutely flat surface is required when embedding the thin skin for sectioning. A slight fold or unevenness will result in an uneven section through the levels of different follicle groups. Some follicles will be cut slightly deeper than others, making identification of accessory structures and thus follicles difficult (39).

Primary follicle development occurs in four stages (13,14). First, single, evenly spaced central primary follicles (PCX) appear in the developing fetus. Next, a second population of single primary follicles (PCY) appears between the PCX follicles. As growth occurs the two types become identical in appearance. Third, two lateral primary follicles (PLx) form, one on each side of the PCX follicles. Fourth, two lateral PLY follicles form, one on each side of the PCY follicles. Each PC follicle and its two laterals is referred to as a triad. Occasionally, a fifth stage of development occurs in which two extra laterals (PLx+ or PLY+) occur, one on each side of the triad (39). All of these stages of primary follicle development occur before birth.

Most maturation of the secondary follicles takes place after birth, though the follicles may be initiated prenatally. The ratio of secondary to primary follicles (S/P) at birth has been measured at 2.3:1 in South African Angora goats (4) and 2.6:1 in Texas samples (8). This ratio indicates that follicle groups at birth contain a triad of primary follicles and about seven secondaries. The ratio increases for three to four months until the final S/P ratio is 6.5:1 to 8.3:1 in Texas animals (20) and 9.1:1 in South African samples (4). The kemp content of the coat reflects the S/P ratio. At birth, the Angora goat's coat consists mainly of long kemp fibers. After the first six months of life the coat consists primarily of mohair. Kemp content in the fleece of newborn kids may be as high as 44 percent, decreasing to 15.7 percent at one month and 7.3 percent at three months as fiber production from secondary follicles increases (4).

Various investigators who have studied the manner of shedding and regrowth of fibers in the Angora differ in some details concerning age and seasonal factors. Dreyer and Marincowitz (4) state that kemp fibers shed seasonally, but mohair grows from a persistent hair germ and is not shed seasonally. Shedding of

kemp fibers starts soon after birth and continues for three months. On the other hand, Margolena (21), in a detailed histological study of non-growing mohair fibers, reported that shedding does not commence after birth until the complete follicular population becomes established. At about 2 months of age, the primaries begin to shed, followed gradually by cyclical shedding in the secondary follicles. Shelton and Bassett (29) also mention that some animals shed mohair in the spring. The number of nongrowing follicles increases with age in both Texas and South African does. Follicle inactivation is higher in Texan does; for example, 27 percent of follicles in 6-year-old Texas does are inactive in winter versus 8.75 percent in 6-year-old South African does (21). Shedding is presumably influenced by both heredity and environment.

Biochemically induced shedding. Primary and secondary follicles have developmental differences. This fact may be the basis for constructing a pharmaceutical means of separating fiber types by the induction of simultaneous shedding in the secondary follicles. Practical application of such a method is probably many years away. However, biochemically induced shedding is currently under study in Australian sheep, according to a recent scientific news article (11). Researchers report that a biological agent, epidermal growth factor (EGF), when infused or injected into sheep, causes the wool to fall off within seven days. At most, only gentle rubbing is required to pull away the fleece. Within another week, new wool growth is visible. Moreover, the treatment causes only the body regions growing true wool fibers to shed, and not hair-growing regions. EGF causes fiber shedding by bringing on temporary, synchronized inactivation of cells at the base of the follicle. The fiber diameter is thus reduced, and the wool fiber breaks off. Preliminary findings on the defleecing of fetal and adult sheep by EGF have been reported (34), as well as a detailed examination of the effects of EGF on wool fiber morphology and skin histology in Merino ewes (22).

The use of EGF, which is extracted in minute amounts from the submaxillary glands of male mice, is extremely cost prohibitive for commercial applications. EGF could be applied to the harvesting of mohair only if an inexpensive source could be found. Potentially, such a harvest would be kemp-free. Furthermore, the study implies a basic biochemical difference between primary and secondary follicle fiber production that is under the control of hormones or growth factors. Further study of the mechanism of shedding could lead to the discovery of less expensive biochemical agents to stimulate synchronized shedding of the mohair follicles.

Genetics and Management of Kemp

Heritability and inheritance. Kemp in mohair is continually selected against by breeders using mass selection techniques. Breeding animals are chosen by low kemp scores, usually based on visual appraisal. The success of this practice depends upon the relative importance of heredity and environment in kemp

formation and the accuracy of visual appraisal. Heritability estimates the degree to which a measurable trait or phenotype, such as kemp, is influenced genetically and can thus be modified by phenotypic selection. The heritability of kemp was estimated in one sample of Texan Angoras in 1970 at 0.43 by comparing the resemblance in kemp score between paternal half-siblings (29). This relatively high heritability estimate indicates that good progress can be expected by selectively breeding against kemp. On the other hand, in 1983 other estimates were reported based on half-sibling methods and sire-offspring comparisons (32). The heritability of kemp was estimated from genetic studies of 312 offspring and 22 sires to be between 0.052 and 0.190, suggesting that further reduction of kemp levels by breeding will be slow. Kemp scores for each animal were based on subjective scores ranging from 0 (none) to 5 (excessive). However, the heritability coefficient measures only a particular population at a certain time and is not constant for all herds. Thus other estimates of heritability would be valuable for effectively planning breeding strategies to eliminate or reduce kemp levels. Furthermore, the estimates should be based on objective kemp measurements.

The genetics of kemp inheritance, as well as other fleece characteristics, has not been worked out. Because the mohair coat is a hyper-developed undercoat and kemp fibers are vestigial guard hairs, a hypothesis may be formed that the kempless trait is a mutation in which guard hairs are abnormally underdeveloped. This condition exists in four breeds of cats: Cornish rex, German rex, Devon rex, and Oregon rex. In each of these four rex breeds a single recessive gene controls this coat characteristic (lack of guard hairs), a finding demonstrated by cross breeding rex animals with normal-haired cats. Offspring from crosses between Cornish and Devon, Oregon and Cornish, and Oregon and Devon rex cats have normal hair, indicating that the Cornish, Devon and Oregon rex genes are independent of each other. Offspring of Cornish X German rex crosses express the rex trait, indicating that these two rex mutants are either identical or are alleles at the same locus. Other factors also influence the expression of the rex gene, since individuals show variation in the amount of guard hair they express (25-27).

If the kempless trait in Angora goats is comparable to the Rex trait in cats, analysis of offspring from crosses between Angora and wild-type goats might reveal the mechanism of kemp inheritance. If lack of kemp is inherited like the Rex trait as a simple recessive trait, half-Angora offspring should have the same percentage of kemp fibers as their non-Angora parents. If another mechanism of inheritance governs kemp, crossbred offspring may have an amount of kemp intermediate to that of their parents.

Critical to the evaluation of existing literature on Angora crossbreds is the method of measuring and reporting kemp content. Unfortunately, published crossbreeding experiments yield very little information of use for genetic analysis because the method is

unspecified or inadequate for this purpose. For example, hybrids from crosses between local (Deccani) does and Angora bucks in India (18) were reported to yield fleeces with 29.31 percent medullated (both kemp and heterotype) fiber compared to 90.05 percent in local goats and 2.79 percent in pure Angoras. The percentages given represent the number of medullated fibers per total fiber number in the fleece sample (24). Because no distinction was made between kemp and heterotypic fibers, the mode of inheritance for kemp cannot be determined. Kemp levels in crossbreds and Deccani goats may or may not have been identical.

An adequate method for comparing kemp levels in purebreds and crossbreds may be difficult to devise. The reduced kemp level in Angora goats is a more complex situation than a simple lack of guard hairs in Rex cats because 1) at least two factors govern the expression of kemp and 2) the mohair undercoat has itself undergone extensive genetic change from the wild type. The factors that influence the expression of kemp are the S/P ratio and the fiber producing activity of the primary follicles. Because the S/P ratio is in the order of 8:1 (20) in Texas Angora goats, about 11 percent of the fleece fibers would be kemp if all the follicles were active. Because kemp levels of well bred goats are less than 4 percent (37), most of the primary follicles must be either inactive or producing partially nonmedullated fibers. As discussed, primary follicles undergo shedding and resting stages and can produce heterotypic fibers. Indeed, in Texas and South African animals studied by Margolena (20), Angora goats usually produced no medullated hairs from lateral primary follicles and sometimes produced incompletely medullated fibers from central primary follicles.

A high S/P ratio is one of the adaptations bred into Angora goats for increased growth of the undercoat. For example, the S/P ratio of American dairy goats, which are not specialized for fiber production, is 2.97:1 (19), in contrast to the earlier mentioned 8:1 ratio in Texas Angora goats. The high S/P ratio of Angora goats has a moderately high heritability coefficient of 0.52 (40,41). Other adaptations for increased growth of the undercoat are increased fiber length from secondary follicles, as reflected in staple lengths of 10.99 cm in Angora goats vs. 2.79 cm in Deccani goats (18), and increased diameter of the fibers. In contrast to the Angora goat, the Spanish goat displays a much finer undercoat (9). The evolutionary tendency of the Angora goat has been towards uniformity of coat, with a loss of fiber fineness as the undercoat developed to its present state. Van Rensburg (38) links the genetically determined high rate of hair growth in Angora goats to a low level of adrenal function. Adrenal hormones inhibit hair growth by reducing fiber diameter and length. He further suggests that hair production takes precedence over fetal development, especially during nutritional stress, thus leading to a high abortion rate in animals that produce more mohair than normal controls.

The tentative conclusion that can be drawn from these sketchy data is that crossbreds and purebreds can be compared in crossbreeding experiments on the basis of kemp fibers per follicle group. This measurement would correct for inactive primary follicles, primary follicles producing non-medullated fibers, and S/P differences between purebred Angoras and other genetic groups. Perhaps the factor of ultimate importance in selection for kempless goats is the inactivation at maturity of the primary follicles, or their production of nonkemp fibers.

Phenotypic and genotypic correlations. Estimates of correlations between kemp levels and other measurable traits (phenotypic correlations) and between their genetic components (genotypic correlations) are needed in devising breeding programs to preserve desirable traits while reducing kemp levels. A phenotypic correlation between traits includes both genetic and environmental components, the latter of which may coincide with or oppose the genetic component. Phenotypic correlations between kemp content and other fleece characteristics would indicate whether kemp-free animals would be superior or inferior in the phenotypic level of some other trait, such as clean fleece weight. A genetic correlation between two traits indicates the degree to which the genes governing the traits are inherited together. A genetic correlation is caused by genetic linkage, where the genes for two traits are closely associated on the same chromosome, or by pleiotropy, where the same gene or genes influences more than one trait.

Only two studies have estimated phenotypic and genotypic correlations between kempiness and other traits, including body weight, several fleece traits, and body cover (29,32). The amount of kemp in the fleece was assigned an arbitrary score (0 to 4 or 5) with higher values representing greater amounts of kemp. In the first study (29) four low but significant negative phenotypic correlations were found between kemp score and grease weight (-0.152), clean weight (-0.115), neck cover (-0.215), and belly cover (-0.181). A slightly positive phenotypic correlation was found between kemp score and body weight (0.150) and kemp score and staple length (0.166). The kemp score had a strongly negative genetic correlation with several valuable traits: body weight (-0.504), grease weight (-0.750), clean weight (-0.750), and fiber diameter (-0.750). The authors suggest that several advantages might be gained by eliminating kemp.

The second study (32) found that open-faced does had more kemp than does with covered faces and that larger or faster gaining goats tended to have more kemp. The authors speculate that the relationship between rate of growth and kempiness may represent a genetic linkage that could be overcome through selective breeding.

A review of published reports on fleece characteristics other than kemp may provide guidelines for future research. For example, Yalcin et al. (40) report a high negative genetic correlation between the secondary to primary (S/P) follicle ratio and fiber diameter

measured at 5 months of age; i.e., as the S/P ratio increases, fiber diameter decreases. Because heritability of the S/P ratio is high, this criterion may be used for early, indirect selection for fiber fineness. Of particular interest to the kemp problem would be an estimate of the correlation between S/P ratio and kemp content. If a phenotypic correlation were found between the S/P ratio in young kids and reduced kemp levels at maturity, the follicle ratio could be used for the early identification of breeding stock. Because the S/P ratio is probably not strongly influenced by environment, a study of the correlation between S/P and kemp content might provide information on the influence of environment on kemp content.

Of importance to breeders is the finding by Margolena (20) that lock type is related to the amount of medullation. Goats developing ringlet type locks had the lowest incidence of medullation, whereas mixed and flat locks were intermediate. No genetic parameters have been estimated for this relationship. However, lock length is highly heritable, the heritability estimate being 0.593 in a small sample of does and two-year-old kids (30). Shelton and his colleagues imply that lock length indicates lock type or configuration. No published study has reported relative lengths of different lock types, but examination of photographs in articles by Margolena (20,21) and Shelton (28) indicates that ringlet locks are among the longest lock types. A detailed study of genetic parameters regarding kemp and lock type may be very valuable in identifying an easy method for selectively breeding to eliminate kemp.

Effects of season, sex, age, and nutrition. Several factors without direct genetic control over fiber production have been found to affect one or more fleece traits, among them age, body size, sex, and fertility status of females (barren or fertile). Such factors are considered by some researchers to be environmental influences even though they themselves are partly under genetic control. These factors have been studied with respect to greasy and clean fleece weights, yield, fiber diameter, and staple length (3). Several investigators have found that kemp percentages are higher in autumn than in spring in both adult males (33; Bassett, this volume) and in young wethers and does (4). Stapleton (33) speculates that kemp grows in a seasonal manner, more actively in spring and summer, and less actively in autumn and winter.

Very little information is available on sexual differences in the expression of kemp. However Dreyer and Marincowitz (4) studied wethers and does throughout their first two years of life and reported that no differences were observed before 21 months in percentages of medullated hair. After that time, wethers had significantly more medullated hair than does, e.g., 4.6 percent vs. 1.9 percent at 24 months of age.

Age has a slight effect on kemp levels, with kemp and medullated fiber incidence increasing gradually over the lifetime of the animal after maturity (17).

No studies exist on the effects of nutrition on kemp

incidence. Early postnatal nutrition should be critical to fleece development, since most of the secondary follicles mature shortly after birth. Perhaps optimal nutrition would maximize the S/P ratio, and thus reduce the percentage of kemp. Nutrition is known to influence other fleece characteristics. For example, Huston (15) showed that increased caloric intake and protein consumption by weaned Angora female kids resulted in increased fiber growth. Shelton and Huston (31) showed that extremely high protein consumption increased fiber production in yearling males. Further study is needed on the effects of nutrition on developing hair follicles (8).

Management in various countries. The major mohair producing countries are the Union of South Africa, the United States (Texas), and Turkey. Other countries actively developing a mohair industry are Lesotho, the Soviet Union, Australia, India, Argentina, and New Zealand. Information concerning the management of kemp levels in these countries is very scarce because little work is reported in agricultural or veterinary journals. From the information that can be gained, however, Texas producers appear to have the greatest concern with kemp at this time.

In 1979, Texas produced a mohair clip that was criticized by buyers for containing kempy lots (6,10). A committee appointed by the President of the Mohair Council of America to study the situation concluded that the bad clips involved 5 to 10 percent of the Texas flocks. The quality of mohair from purebred Angora goats had not declined; rather, fleeces from crossbred goats were being mixed with good mohair and presented to warehouses and buyers as pure mohair. The committee recommended that producers cull crossbred goats or separately bag kempy mohair and market it as a crossbred mohair. Furthermore, warehousemen and buyers were encouraged to identify problem lots. Texas Agricultural Experiment Station personnel judging Angora goat classes were urged to penalize kempy fleeces.

Groff (10) emphasized that the kemp problem in the 1979 clip did not arise from purebred Angora goats, which produce good quality mohair, but from crossbreeding Angora and Spanish goats. A comparison in Australia of kemp levels from three countries (33) supports this contention. Texas and South African samples contained 1.8 and 1.6 percent kemp, respectively, which was not significantly different statistically, whereas Australian samples contained 3.1 percent kemp. Indeed, the kemp levels reported for well bred Texas Angora goats are in the order of 0.14 to 0.80 percent (Bassett, this volume). Perhaps problem clips could be dealt with more efficiently if a system of grading were employed for Texas mohair. Except for the separation of age groups, because age influences fiber fineness, grading is rarely practiced and, when practiced, does not encompass kemp content (28).

In South Africa both extensive grading and extensive selection in breeding for improved fleece characteristics are practiced. Sixty-seven grades of mohair are allowed for, including stratifications for age, fiber

length, fiber diameter, lock type, and kemp content. One result of improved breeding is that mohair production per goat was very high in 1980: 4.35 kg, compared to 3.70 kg in Texas, 2.25 kg in Turkey, 1.00 kg in Argentina, and 0.75 kg in Lesotho (37). South African goats also have a higher S/P ratio than Texas Angoras (4), less variation in the number of secondary follicles per follicle group (21), lower percentages of follicles becoming inactive with age (21), and greater depth of penetration of the follicles into the dermis (20,21). The percentage of medullated fibers, including kemp and gare, is typically reported by South African workers, rather than kemp content. Other than the Australian study previously mentioned, no single study is available that compares kemp content from Texas and South Africa. Mention is made by Shelton (28) that in South Africa, where Angora goats are selected for fiber fineness, the rate of abortion has reached a serious level. He suggests that fiber fineness is related to abortion, although, as previously discussed, frequent abortion is linked to higher levels of mohair production, a trait also selected for in South African animals.

Turkey has produced the most complete studies of environmental and genetic influences on production traits in Angoras to date (3,40,41). The goal of such studies is to identify the genetic progress that can be expected from selection for a trait within a particular population and to use genotypic correlations for indirect selection of traits that are difficult to measure. Selection methods based on this information may more quickly improve flocks than traditional mass selective breeding based on measurements of fleece traits (41). Kemp was not one of the factors studied, suggesting that it is not a major concern to Turkish producers. Kemp percentages have been reported at 0.62-1.30 percent (35) and 1.06-3.00 percent (36). Mohair is graded according to nine basic classes: first grade kid, second grade kid, fine mohair, good mohair, ordinary mohair, Kastamonu mohair, Konya mountain mohair, Konya plain mohair, and Cengelli (16).

In India, experiments are underway to develop an Indian Angora goat by crossbreeding with local Deccani goats (18,23). Early results indicate that 7/8 Angora crosses compare acceptably to purebreds with respect to percent medullation, staple length, and fiber diameter. Kemp levels were not measured.

In Australia, unlike Texas or South Africa, heterotypic (gare) fibers present a problem to producers (83). The method of evaluating hair samples emphasizes this viewpoint, since two types of gare are allowed for, in addition to kemp and mohair types. Gare is suggested to be a greater problem than kemp because it is long and cannot be removed by combing. Furthermore, gare is difficult to assess by visual appraisal. The reason for increased gare levels in Australian goats appears to be its correlation to increased fleece weight. This relationship may reflect the fact that as fiber diameter increases, medullation increases (12).

Discussion and Conclusions

The following types of studies are needed to allow a more efficient approach in establishing breeding and management programs to reduce kemp levels:

1. Obtain new heritability estimates for kemp and related characteristics, such as S/P ratio, lock type, and fiber diameter. These estimates must be based on adequate samples. Attempts should be made to correct for environmental factors, such as nutrition, in estimating heritability. The effect of nutrition on kemp levels must be determined.
2. Determine genotypic and phenotypic correlations between kemp and certain fleece and skin characteristics, in particular S/P. The use of the S/P ratio in young animals as an early indication of kemp levels depends on finding a positive correlation between S/P and kemp.
3. Study histogenesis to determine how primary follicle inactivation and/or alteration of production from kemp to non-kemp fibers reduces the kemp level of mature animals. The heritability of primary follicle inactivation should be determined.
4. Test for biochemical and histochemical differences between primary and secondary follicles in active and resting stages. Differences in hormonal responses of the follicle types may be found that will aid in the development of biochemical shearing methods.

For the present, producers can selectively breed using animals with low kemp levels as determined by the microscopic method of the American Society for Testing Materials. Visual appraisal is inadequate for identifying the best animals for breeding. Selecting animals with ringlet locks and fine fibers will probably aid in the reduction of kemp.

Literature Cited

1. American Society for Testing Materials. 1980. Diameter of wool and other animal fibers by microprojection. Annual Book of ASTM Standards, Part 33, D-2130.
2. American Society for Testing Materials. 1980. Medullation and kemp fibers in wool and other animal fibers. Annual Book of ASTM Standards, Part 33, D-2968.
3. Arıturk, E., B. D. Yalcin, F. Imeryuz, S. Muftuoglu, and N. Sincer. 1979. Genetic and environmental aspects of Angora goat production 1. General performance levels and the effects of some measurable environmental factors on the production traits. Istanbul Universitesi Veteriner Fakultesi Dergisi 5: 118.
4. Dreyer, J.H. and G. Marincowitz. 1967. Some observations on the skin histology and fibre characteristics of the Angora goat (*Capra hircus angoraensis*). South African Journal of Agricultural Service 10:477-500.
5. Duerden, J.E. and M.R. Spencer. 1930. The coat of the Angora goat. Department of Agriculture, Union of South Africa, Bulletin 83.
6. Earwood, A. 1979. The problem: kemp. Special newsletter. Mohair Council of America. San Angelo, Texas.
7. Engdahl, G.R. and J.W. Bassett. 1971. Mohair variation on the Angora goat. Pp. 66-68 in Tex. Agri. Expt. Sta. PR-2934.
8. Gallagher, J.R. 1972. Postnatal secondary follicles maturation in the Angora goat. Pp. 32-33 in Tex. Agri. Expt. Sta. PR-3028.
9. Gallagher, J.R. and M. Shelton. 1973. Fiber traits of primitive and improved sheep and goats. Pp. 36-37 in Tex. Agri. Expt. Sta. PR-3190.
10. Groff, J.L. 1979. The problem: kemp. Special newsletter. Mohair Council of America. San Angelo, Texas.
11. Hansen, J. 1982. Biological clippers. Science '82 3:82-84.
12. Hardy, J.I. 1927. Studies of the occurrence and elimination of kemp fiber in mohair fleeces. U. S. Department of Agriculture Technical Bulletin 35:1-16.
13. Hardy, M.H. and A.G. Lyne. 1956a. The pre-natal development of wool follicles in merino sheep. Australian Journal of Biological Science 9:423-441.
14. Hardy, M.H. and A.G. Lyne. 1956b. Proposed terminology for wool follicles in sheep. Nature 177: 705-706.
15. Huston, J.E. 1980. Supplemental energy and protein effects on growth rate and mohair production in weaned Angora female kids. Pp. 58-62 in Tex. Agri. Expt. Sta. PR-3706.
16. Imeryuz, F. 1967. Some breeding techniques of Angora goats and some properties of mohair in Turkey. Rivista di Zootecnia Numero Speciale 14-16: 170-172.
17. Jones, J.M. 1935. Effect of age, sex, and fertility of Angora goats on the quality and quantity of mohair. Pp. 1-34 in Tex. Agri. Expt. Sta. B-516.
18. Koratkar, D.P. and V.K. Patil. 1982. Fiber quality in Angora, local and crossbred goats. P. 527 in Proceedings of the Third International Conference on Goat Production and Disease. Dairy Goat Journal Publishing Company, Scottsdale, AZ.
19. Margolena, L.A. 1959. Skin and hair follicle development on dairy goats. Virginia Journal of Science 10:33-47.
20. Margolena, L.A. 1966. Lock type, follicular characteristics and medullation in Texas and South African Angora does. Virginia Journal of Science 17:32-39.
21. Margolena, L.A. 1974. Mohair histogenesis, maturation, and shedding in the Angora goat. U. S. Department of Agriculture Technical Bulletin 1495:1-20.
22. McDonald, B.J., J.J. Waters, M.D. Richards, G.D. Thorburn, and P.S. Hopkins. 1983. Effect of epidermal growth factor on wool fibre morpholo-

- gy and skin histology. *Research in Veterinary Science* 35:91-99.
23. Patil, V.K. 1982. A crossbreeding experiment to evolve an Indian Angora breed. P. 509 in *Proceedings of the Third International Conference on Goat Production and Disease*. Dairy Goat Journal Publishing Co. Scottsdale, AZ.
 24. Patil, V.K. Mahatma Phule Agricultural University, Rahuri 413, 722, Maharashtra, India. Personal communication.
 25. Robinson, R. 1968. German rex: a rexoid coat mutant in the cat. *Genetica* 39:351-352.
 26. Robinson, R. 1971. The rex mutants of the domestic cat. *Genetica* 42:466-468.
 27. Robinson, R. 1972. Oregon rex—a fourth rexoid coat mutant in the cat. *Genetica* 43:236-238.
 28. Shelton, M. 1981. Fiber production. Pp. 380-409 in (C. Gall) *Goat production*. Academic Press, London.
 29. Shelton, M. and J.W. Bassett. 1970. Estimate of certain genetic parameters relating to Angora goats. *Tex. Agri. Expt. Sta. PR-2750*.
 30. Shelton, M., S.P. Davis, and J.W. Bassett. 1965. A preliminary study of the importance of staple length in selecting Angora goats. Pp. 25-26 in *Tex. Agri. Expt. Sta. PR-2343*.
 31. Shelton, M. and J.E. Huston. 1966. Influence of level of protein and other factors on the performance of yearling billies maintained in drylot. Pp. 24-26 in *Tex. Agri. Expt. Sta. PR-2399*.
 32. Shelton, M. and G. Snowden. 1983. Some genetic parameter estimates for Angora goats. Pp. 165-173 in *Tex. Agri. Expt. Sta. PR-4171*.
 33. Stapleton, D.L. 1976. Medullated fiber in the Australian Angora goat fleece. *Proceedings of the Australian Society of Animal Production* 11:45-48.
 34. Thorburn, G.D., M.J. Waters, I.R. Young, M. Dolling, D. Buntine, and P.S. Hopkins. 1981. Epidermal growth factors: a critical factor in fetal maturation? Pp. 172-189 in *The fetus and independent life*. Pitman, London (CIBA Foundation Symposium 86).
 35. Utkanlar, N. and F. Imeryuz. 1959. Muhtelif yaslardaki ankara kecilerinin omuz, kaburga, but bolgeleri tiftikelerinde kemp ve medullali elyaf miktarlari. *Lalahan Zootek Arastirma Enstitusu Dergisi* S.3:35-46.
 36. Utkanlar, N., F. Imeryuz, M. Orkiz, and H. Kara. 1961. Turk tiftiklerinde derecesi, kemp ve medullali elyaf nispetinin, bularin onemli yetistirme bolgelerinin deki durumlarini uzerinde mukayeseli bir arastirma. *Lalahan Zootek Arastirma Enstitusu Dergisi* S. 8-9:85-105.
 37. Van der Westhuysen, J.M. 1982. Mohair as a textile fiber. Pp. 264-268 in *Proceedings of the International Conference on Goat Production and Disease*. Dairy Goat Journal Publishing Co. Scottsdale, AZ. pp. 264-268.
 38. Van Rensburg, S.J. 1971. Malnutrition of the foetus as a cause of abortion. *Journal of the South African Veterinary Medical Association* 42:305-308.
 39. Wentzel, D. and J.H. Dreyer. 1969. A new type of primary follicle in the skin of Angora goats—the PL+ follicle. *South African Journal of Agricultural Science* 10:1049-53.
 40. Yalcin, B.C., E. Ariturk, F. Imeryuz, N. Sincer, S. Muftuoglu, 1979. Genetic and environmental aspects of Angora goat production 2. Phenotypic and genetic parameters for important production traits. *Istanbul Universitesi Veteriner Fakultesi Dergisi* 5:19-34.
 41. Yalcin, B.C. 1982. Angora goat breeding. Pp. 269-278 in *Proceedings of the Third International Conference on Goat Production and Disease*. Dairy Goat Journal Publishing Co., Scottsdale, AZ.

Acknowledgement

Funding for this review was provided by the Mohair Council of America.

PR-4404

Carcass Grades, Rack Composition and Tenderness of Sheep and Goats as Influenced By Market Class and Breed

R.R. Riley, J.W. Savell, D.D. Johnson, G.C. Smith, and M. Shelton

Summary

Compared to goats, sheep had more youthful USDA overall maturity scores, higher flank streaking scores, higher USDA leg conformation scores, larger longissimus muscle areas, and produced loin chops with lower shear force values. Rambouillet sheep had higher scores for USDA skeletal and overall maturity, more feathering and flank streaking, higher USDA leg conformation scores, and produced loin chops with lower shear force values than Barbados and Karakul sheep (especially the young intact males) had higher adjusted fat thicknesses than the other breeds due to heavy fat deposition near the dock. Racks from young intact males tended to have higher percentages of lean than racks from aged females within most breeds.

Introduction

In many parts of the world the sex classes of sheep and goats that would be most available for slaughter would be young intact males and aged females which had surpassed their usefulness as breeding animals. In most countries, the economic or biological basis for castration of male sheep or goats is less evident than would be inferred from the widespread use of this practice in the United States. Thus, research involving

these market classes should be of major interest as a way to maximize yields of meat from these species. This is an important step when evaluating the characteristics of market classes available to lesser developed countries.

Goats are often raised with sheep and may be competitive for feed resources and market outlets. Therefore, there is a need to characterize goats and certain types of sheep in terms of qualitative and quantitative aspects of their carcasses and meat. The present study was undertaken to obtain data regarding qualitative and quantitative characteristics of carcasses from sheep and goats with regard to effects of species, market class and breed on their value as meat producers.

Experimental Procedure

Sheep or goats (n=120) consisting of two market classes and representing five breeds—Angora and Spanish goats and Rambouillet, Barbados Blackbelly and Karakul sheep—were slaughtered for this study.

At approximately 48 hours postmortem, Texas Agricultural Experiment Sta. personnel obtained data for quality and yield grade factors from each carcass. The factors evaluated were USDA skeletal, lean, and overall maturity; intercostal feathering; flank streaking; USDA leg and carcass conformation; actual and adjusted fat thickness, 12th rib; kidney and pelvic fat percentage; and longissimus muscle area at the 12th rib.

The 6th through 12th rib rack was removed from each carcass on the second day postmortem and split longitudinally through the center of the thoracic vertebrae.

Each rack was physically separated into "soft tissue" (subcutaneous fat, intermuscular fat and lean) and bone. The "soft tissue" and bone were each weighed and the percentage bone was calculated as a percentage of the total rack weight. The "soft tissue" was thoroughly ground, sampled, frozen in liquid nitrogen, powdered in a blender and subsampled for fat analysis by extraction with diethyl ether. Fat percentages in soft tissue were used to calculate the total percentage fat and fat-free lean in each rack as a percentage of the total rack weight.

On the second day postmortem, the wholesale loin was removed from each carcass. Loins were cut into as many chops (1.5 inches) as could be obtained from the short loin and were wrapped with polyethylene-coated paper and stored at -20°F.

Chops were removed from the freezer, thawed approximately 24 hours and roasted to 158°F internally in a gas oven. Chops were cooled to room temperature, cores were removed from the longissimus muscle of each chop, and shear force determinations were obtained with a Warner-Bratzler shear machine.

Data were analyzed by analysis of variance and Duncan's multiple range (when $P < .05$, main effects were observed). The model included tests for differences between species (goats vs. sheep), market classes (young intact males vs. aged females), breeds of goats (Angora vs. Spanish), breeds of sheep (Rambouillet vs. Barbados Blackbelly vs. Karakul) and the interactions for market class x specie and market class x breed within species. For traits where no significant interactions were present, main effect means were separated and reported in Table 1. For traits where significant interactions occurred (either market class x

Table 1. Comparison of least-squares means of certain carcass and shear force traits and segregated species, market class and breeds within species^a

Item	USDA skeletal maturity	USDA overall maturity	Feathering	Flank ^b streaking	USDA leg conformation	Kidney and pelvic fat, %	Longissimus muscle area, in ²	Warner-Bratzler shear force, lb
Species								
Goat (n=43)	YM ^{00c}	B ^{93c}	Sm ^{07c}	Tr ^{63c}	Gd ^{42c}	2.0 ^c	1.2 ^d	19.0 ^d
Sheep (n=77)	B ^{96c}	B ^{74d}	Sl ^{72c}	Sl ^{31d}	Ch ^{43d}	2.0 ^c	1.8 ^c	14.8 ^c
Market class								
Young intact males (n=60)	A ^{94c}	A ^{83c}	Sl ^{81c}	Tr ^{95c}	Gd ^{96c}	1.9 ^c	1.6 ^c	17.2 ^c
Aged females (n=60)	M ^{03d}	YM ^{84d}	Sl ^{97c}	Tr ^{99c}	Gd ^{89c}	2.1 ^c	1.3 ^d	16.5 ^c
Breed of goats								
Angora (n=19)	B ^{75c}	B ^{73c}	Sl ^{80c}	Tr ^{64c}	Gd ^{34c}	1.6 ^c	1.0 ^d	18.7 ^c
Spanish (n=24)	YM ^{26d}	YM ^{13d}	Sm ^{34c}	Tr ^{61c}	Gd ^{50c}	2.4 ^d	1.4 ^c	19.2 ^c
Breed of sheep								
Rambouillet (n=25)	B ^{70c}	B ^{51c}	Sm ^{33c}	Sl ^{86c}	Ch ^{72c}	2.2 ^c	1.7 ^c	12.1 ^c
Barbados Blackbelly (n=25)	YM ^{09d}	B ^{88d}	Sl ^{08e}	Tr ^{80d}	Ch ^{16d}	1.9 ^c	1.7 ^c	16.8 ^d
Karakul (n=31)	YM ^{11d}	B ^{83d}	Sl ^{74d}	Sl ^{28d}	Ch ^{40d}	1.8 ^c	1.8 ^c	15.2 ^d

^aAll carcasses were graded using USDA (1969) standards for lamb carcasses. For maturity: A=A maturity, B=B maturity, YM=Yearling mutton, and M=mutton; for feathering and flank streaking: Tr=Traces, Sl=Slight, and Sm=Small; for leg conformation: Ch=U.S. Choice, Gd=U.S. Good.

^bAverages of scores for primary and secondary flank streaking.

^{c,d,e}Least-squares means within a group in the same column superscript letter are not different ($P > .05$).

species or market class x breed within species), means and standard deviations for the interaction combinations are presented in Table 2. No mean separation was performed on traits where significant interactions were observed.

Results and Discussion

In the present study, when comparisons were made between sheep and goats (Table 1), sheep carcasses were more youthful (USDA overall maturity), had higher flank streaking and USDA leg conformation scores and larger longissimus muscle areas, and produced loin chops with lower shear force values than did goat carcasses. Sheep and goat carcasses did not differ in USDA skeletal maturity, feathering or percentage kidney and pelvic fat. When comparing market classes (Table 1), no differences were found between market classes for feathering, flank streaking, USDA leg conformation, kidney and pelvic fat percentage or shear force values; however, young intact males had larger longissimus muscle areas and, as expected, had more youthful USDA skeletal and overall maturity scores than did aged females.

Table 1 shows that Angora goats and Spanish goats did not differ in feathering, flank streaking, USDA leg conformation scores, and shear force values for loin chops; however, Angora goats had more youthful USDA skeletal and overall maturity scores, smaller longissimus muscle areas, and lower kidney and pelvic fat percentages than did Spanish goats.

Rambouillet sheep had higher flank streaking, feathering and USDA leg conformation scores and

more youthful USDA skeletal and overall maturity than either Barbados Blackbelly or Karakul sheep (Table 1). Furthermore, loin chops from Rambouillet sheep had lower shear force values than did loin chops from any of the other breeds of sheep. With the exception of feathering, Barbados Blackbelly and Karakul sheep did not differ for any other trait listed in Table 1.

Means and standard deviations for certain carcass traits and tissue components where interactions were observed are presented in Table 2. It appears that differences existed among breeds of sheep and goats for carcass traits and rack tissue components. Rambouillet and Karakul sheep tended to have higher USDA quality grades, conformation scores, and flank firmness scores. Angora goats, Spanish goats, and Barbados Blackbelly sheep tended to have lower numerical yield grades and the least actual and adjusted fat thickness and had racks that contained lower fat percentages and higher lean percentages. Young intact male Spanish goats exhibited the most evidence of "buckiness" and, as a result, had the lowest USDA quality grades (with the "buckiness" discount). Furthermore, the fat thickness of Karakul carcasses was adjusted much more than that of the other breeds because of their heavy fat deposits near the dock.

It appeared that market class within breeds did not affect USDA carcass conformation, except for Angora goats and Karakul sheep. Except for Rambouillet and Karakul sheep, market class within breeds did not appear to affect actual fat thickness; and except for Karakul and Rambouillet, market class did not appear

Table 2. Means and standard deviations for certain carcass traits and rack tissue components^a

Trait	Goats				Sheep					
	Angora ^b		Spanish		Rambouillet		Barbados Blackbelly		Karakul	
	YIM (n=9)	AF (n=10)	YIM (n=7)	AF (n=17)	YIM (n=12)	AF (n=13)	YIM (n=11)	AF (n=10)	YIM (n=21)	AF (n=10)
Flank Firmness	TSF ⁴¹ (55.6)	STS ⁵⁶ (67.9)	TSF ²¹ (48.8)	TSF ¹⁶ (113.4)	SF ⁶⁹ (110.4)	SF ⁵⁷ (157.0)	TSF ³⁹ (79.3)	TSF ³⁵ (62.4)	SF ⁴⁸ (71.2)	STS ⁸⁹ (119.0)
USDA carcass conformation	Gd ⁵⁷ (16.6)	Ut ⁸⁶ (38.6)	Gd ¹⁴ (47.2)	Gd ²⁹ (75.2)	Ch ⁶⁸ (24.2)	Ch ⁵⁵ (42.2)	Gd ⁹⁵ (47.0)	Gd ⁹¹ (69.7)	Ch ³⁰ (22.8)	Gd ⁹⁴ (82.2)
USDA quality grade (w/out buckiness discount)	Gd ⁶⁸ (22.8)	Ut ⁷⁶ (30.0)	Gd ²³ (36.2)	Ut ⁹⁶ (48.8)	Ch ⁵¹ (30.9)	Gd ⁵⁷ (47.9)	Gd ⁵³ (44.5)	Gd ⁰⁶ (41.9)	Ch ¹⁵ (36.7)	Ut ⁹⁵ (56.6)
USDA quality grade (with buckiness discount)	Gd ⁵⁰ (36.1)	Ut ⁷⁶ (30.0)	Ut ⁵⁹ (46.1)	Ut ⁹⁶ (48.8)	Ch ⁴³ (36.2)	Gd ⁵⁷ (47.9)	Gd ²¹ (57.2)	Gd ⁰⁶ (41.9)	Ch ¹⁰ (38.6)	Ut ⁹⁵ (56.5)
Actual fat thickness, 12th rib in	.03(.03)	.02(.04)	.04(.04)	.02(.04)	.09(.04)	.20(.14)	.04(.02)	.04(.03)	.12(.06)	.09(.07)
Adjusted fat thickness, 12th rib, in	.04(.03)	.02(.04)	.04(.04)	.05(.05)	.11(.03)	.17(.10)	.05(.03)	.06(.04)	.22(.07)	.15(.09)
USDA Yield Grade	1.9(0.3)	1.8(0.4)	2.1(0.3)	2.2(0.6)	2.3(0.3)	2.8(0.8)	1.8(0.2)	2.1(0.4)	3.1(0.5)	2.4(0.8)
Lean, %	63.4(4.3)	63.4(4.2)	64.4(5.5)	57.7(3.6)	57.3(4.3)	52.7(5.7)	64.8(3.4)	61.3(3.0)	58.2(3.0)	59.0(5.3)
Fat, %	14.1(6.1)	11.7(4.4)	13.5(6.0)	19.5(7.0)	21.4(4.9)	29.2(7.5)	11.8(2.7)	15.7(5.8)	21.5(4.4)	16.2(7.9)
Bone, %	22.5(2.0)	24.9(2.0)	22.1(2.0)	22.8(5.1)	21.3(2.7)	18.1(4.3)	23.4(2.6)	23.0(4.7)	20.3(2.5)	24.8(3.4)

^aAll carcasses were graded using USDA (1969) grade standards for lamb carcasses. For flank firmness: STS = tends to be slightly thin and soft, TSF = tends to be slightly full and firm, and SF = slightly full and firm; for conformation and quality grade: Ut = U.S. Utility, Gd = U.S. Good, and Ch = U.S. Choice.

^bYIM = Young intact males; AF = Aged females.

to affect adjusted fat thickness within breeds. Young intact males had firmer flanks than aged females for Angora and Karakul breeds. Within Rambouillet sheep, young intact males had lower numerical yield grades than aged females, but in the Karakul sheep, aged females had lower numerical yield grades than young intact males.

Within breeds, racks from young intact males contained higher percentages of lean and lower percentages of fat than did those from aged females for Spanish, Rambouillet and Barbados Blackbelly breeds, and higher percentages of fat and lower percentages of lean than did those from aged females for the Angora and Karakul breeds (Table 2). Racks from young intact male Angora goats and Karakul sheep contained lower percentages of bone than did those from aged females within their respective breeds and racks from young intact male Rambouillet sheep had higher percentages of bone than did those from aged female Rambouillet sheep (Table 2).

In conclusion, sheep had more youthful USDA overall maturity, higher flank streaking scores, higher USDA leg conformation scores and larger longissimus muscle areas, and produced loin chops with lower shear force values than did goats. Furthermore, loin chops from Rambouillet sheep had lower shear force values than did those from other sheep breeds that were also more advanced in maturity and of lower feathering and flank streaking scores. Young intact males had more youthful USDA skeletal and overall maturity scores than aged females while Angora goats had more youthful USDA skeletal and overall maturity scores than Spanish goats. In addition, Rambouillet and Karakul sheep tended to have higher scores for flank firmness and USDA carcass conformation, higher USDA quality grades, higher numerical yield grades and greater actual and adjusted fat thicknesses than did the other sheep breeds. Karakul sheep (especially the young intact males) tended to have higher adjusted fat thicknesses than the other breeds due to the heavy deposit of fat near the dock of Karakul sheep. Finally, racks from young intact males tended to have higher percentages of lean than did racks from aged females within most breeds.

Acknowledgements

This work was carried out as part of the United States Agency for International Development, Title XII Small Ruminants Collaborative Research Support Program under Grant No. AID/DSAN XII-C-0049, in collaboration with Empresa Brasileira de Pesquisa Agropecuaria, Brazil, and by the Natural Fibers and Food Protein Commission of Texas, Dallas.

PR-4405

New Concepts in Marketing and Merchandising Lamb

G. C. Smith, J. W. Savell, and H. R. Cross

"Lean, light, luscious, lamb." If that's our goal (11), how do we get there from here? It's "luscious" now, but most of it is neither "lean" nor "light". To make it lean and light, the industry must: (a) recognize that too many lambs are excessively fat, (b) realize that lamb has not been singled out as a food to avoid by medical/dietetic professionals because it is a minor component of the American diet, and (c) react to other meat and protein-source competition by making lamb products fit—not fight—the times.

Recognizing that too many lambs are excessively fat. Lambs with more than .15 inch of external (subcutaneous) fat and/or more than 3.5 percent internal (kidney and pelvic) fat occur far too frequently in the United States. This happens because our marketing system does not reward leanness and penalize excessive fatness. In fact, reluctance of packer buyers to reduce emphasis on dressing percentage in purchasing decisions is a deterrent to improving lean to fat ratio in lamb. The beef industry has partially resolved the dressing percentage/carcass cost/yield grade quandary by dramatically increasing the proportion of slaughter cattle sales on grade-and-weight or in-the-beef bases. Both of the latter forms of transaction remove dressing percentage from the price logic and, therefore, do not further encourage overfinishing of slaughter animals.

Before lambs are bought and sold on any basis other than that which presently prevails, however, buyers for supermarkets and purveyors will have to change their buying practices so that yield grade is factored into the price-to-be-paid equation. At present, they negotiate purchases solely on the basis of quality grade and carcass weight.

There is now an exception among packers. The newest of lamb packers—Rocco Further Processing, Incorporated of Timberville, Virginia—believes that it can produce the highest quality product at the lowest cost only when it controls all the steps necessary for the item's production" (12), so they are vertically integrating the lamb production process. They are using grade, yield, and weight criteria incorporated into the five kinds of breeder/feeder contracts they use to assure supplies of slaughter lambs for further processing. They have a reward and punishment system based on carcass weight (50 to 60 lb is ideal), time-period of delivery (by quarters, with November 1 to January 31 being optimal), USDA quality grade (premiums for Prime and Choice; penalties for Good), physiological age at slaughter (penalties for yearling mutton), and USDA yield grade (premiums for YG 1 and 2; penalties for YG 4 and 5). Because USDA classes (lamb vs.

yearling mutton), quality grades (Prime, Choice, Good vs. Utility) and yield grades (1, 2, 3, 4 vs. 5) bear significantly upon value in the Rocco system, discussion of these traits is warranted.

The major value-determining characteristics for ovine carcasses are those related to: (a) class—physiological age at slaughter, (b) quality—palatability characteristics, and (c) cutability—yield of major retail cuts. Assigning age or maturity classes to carcasses in the manner presently used in USDA grading is decidedly biased against ewe lambs when ewes and wethers are slaughtered at ages greater than 9 months (17). Although ewes appear to mature 60 to 120 days earlier than wethers, the effect of such maturation has no effect on cooked lamb palatability. At actual chronological ages of 9 to 11 months up to 19 to 21 months, from 19 to 82 percent more ewes than wethers were not eligible for classification as "lamb," yet comparisons of palatability of cooked loins and legs either favored ewes over wethers or were the same in 11 of 12 comparisons (17). Clearly, this inequity should be corrected through modification of present USDA classification standards.

USDA lamb grading standards (23, 24) classify carcasses into groups of differing commercial market value by assigning to them quality grades (Prime through Utility) and yield grades (1 through 5). Quality grade standards specify requirements for "quality of lean flesh" (texture, firmness and marbling in relation to apparent maturity) which is related to palatability of lamb cuts. Yield (cutability) grade standards are based on a system of measurements (leg conformation score, fat thickness over the center of the ribeye, percentage of fat in the kidney and pelvic regions) for estimating carcass yields of closely-trimmed boneless major retail cuts. Grade standards for lamb carcasses were revised in 1969 to include cutability as a grade-determining factor via addition of yield grades to the then-existing quality grading system; yield grading was based upon research conducted for the USDA by the Texas Agricultural Experiment Station (TAES) (8,16). The quality grading portion of the official standards was last changed in 1982 as a result of requests from the sheep industry (National Wool Growers Association) to revise the grading standards; revisions in quality grading were based upon research conducted for the USDA by Texas Agricultural Experiment Station (14,17,18,19).

Using lamb and yearling mutton carcasses, TAES scientists (14,17,18,19) determined that differences in USDA quality grades were associated with 0.5, 1.2, 10.2, and 6.8 percent of the observed variability in flavor, juiciness, tenderness and overall palatability ratings for combined primal cuts (leg roasts, rib chops and loin chops). Quality grades were effective for segmenting carcasses into groups according to percentages of "Desirable" vs. "Undesirable" primal cuts; Prime, Choice, Good, and Utility carcasses produced "Desirable" primal cuts in 43, 36, 18, and 12 percent of cases, respectively, and produced "Undesirable" primal cuts in 0, 6, 8, and 12 percent of cases, respectively.

Considered singularly, the five factors then used to

assign quality grades to lamb and yearling mutton carcasses varied quite markedly in their ability to predict overall palatability ratings for primal cuts, with maturity score being least accurate and flank streaking score being most accurate. It was concluded from these data (17) that effectiveness of flank streaking as an indicator of palatability of cooked lamb is actually lessened by combining it (in the manner used in USDA grading) with factors (like conformation and feathering) which are very lowly related to palatability. Moreover, reweighting of the emphasis placed on quality grade factors or use of lower flank streaking alone was greatly superior in palatability-prediction accuracy to use of quality grade, as it was then weighted. Use of flank streaking, in combination with maturity scores, created five new "quality groupings" which produced "Desirable" primal cuts in 59, 42, 21, 18, and 5 percent of cases, respectively; palatability-prediction using flank streaking X maturity was more precise than was that achieved by use of USDA quality grade (17). These results convinced the USDA "that the quality grades could be simplified and at the same time would be improved as predictors of palatability" (24). As a result, USDA grade standard changes were proposed on June 1, 1982 and became effective on October 17, 1982 (24).

The yield grades are more accurate for predicting cutability than any of the prediction equations that had been developed at the time yield grading was initiated; yield grades were able to explain 81 percent of the observed variation in the cutability of 577 lamb carcasses evaluated in a TAES study (16). Of the three factors included in assessments needed to assign yield grades to lamb carcasses, fat thickness (center measure, 12th rib) was most closely related to cutability (71 percent of the variation) while leg conformation score was least closely related to cut-out percentages (19 percent of the variation). Even when the ranges of fat thickness or carcass weight in selected carcass populations were very narrow (15), USDA yield grade was capable of explaining 39 percent to 80 percent of the observed variation in lamb carcass cutability.

From the standpoint of increasing predictive accuracy by assessing traits that can be evaluated on the intact (unribbed, unaltered) carcass, TAES data (15) offer little hope that traits other than those in present use will be identified for use in estimating lamb carcass cutability. The latter researchers concluded that, among groups of carcasses varying little in subcutaneous fat thickness, factors other than those included in the USDA yield grade equation (e.g., ribeye area, carcass weight, kidney-pelvic fat weight) enhanced the accuracy with which cutability can be estimated. Unless lamb carcasses are ribbed in commercial practice (i.e., at packing plants) which is not likely to ever happen, it seems probable that factors presently used to yield grade lambs will continue to be those used for that purpose.

It is possible that it would be beneficial to modify the yield grade standards by changing the maximum fatness levels for carcasses of a given yield grade (e.g.,

at present, a carcass with 0.30 inch of fat thickness, Average-Choice leg conformation and 3 1/2 percent kidney-pelvic fat is a Yield Grade 4.0; a change of the standard from the present 0.30 inch to a new standard of 0.40 inch of fat thickness would allow many more carcasses to qualify for Yield Grade 3). such change in yield grade standards would likely increase packing industry interest in use of the system since it would be less repressive than would be the case if present yield grade standards were implemented. (This is believed to be so because many of the carcasses presently produced are, very probably, of a Yield Grade 4.) Excess fatness is believed to be less of a problem among Spring Lambs and Range Lambs than among Old-Crop Lambs and/or Fed Lambs. Such change in yield grade standards might also lessen the danger which presently exists that very lean (Yield Grade 1, especially) lamb carcasses would produce lean cuts that are too dark to be readily salable at retail (6), that discolor too rapidly during retail display (6) and that might be less than satisfactory in flavor and overall palatability (7).

On the other hand, a change in yield grade lines—to allow fatter carcasses to qualify for a given yield grade—ignores the fact that much of our present lamb supply is too fat. The beef industry is presently seeking modernization of grade standards for their product because they feel that the American consumer is reacting in a negative fashion to fatness of red meat. If health and nutrition concerns on the part of consumers increase further, and lamb remains as fat as it presently is, there will be further erosion of consumer demand for lamb.

If it is the consensus of those in the sheep industry that their product is too fat, and if the industry desires to do something to encourage production of leaner lamb, they should chart a course similar to that set in motion by the beef industry in 1974 when the USDA was asked to make yield grading mandatory for all carcasses that were to be quality graded. Even though mandatory yield grading of lamb would not be a popular idea, especially among meat packers and mandatory yield grading might force wholesalers and retailers to use imported, rather than domestic, lamb, the end (improved leanness) would justify the means. A recent study at TAES (10) compared composition of retail cuts from United States vs. New Zealand lambs; lambs from the United States had higher intramuscular fat content than did lambs from New Zealand.

If yield grading of lamb were made mandatory, it would make possible sale of very heavy carcasses on the basis of their cutability, thus preventing presently excessive discounts in value based solely on the fact that they are heavy and thus presumed to be too fat. However, emphasizing leanness and cutability without simultaneously emphasizing maintenance of quality (especially lean color as it relates to appearance of cuts in the retail case and sufficient youthfulness and fatness to assure desirable flavor, juiciness, and tenderness of cooked product) could be to the detriment of the sheep industry.

It is true that the genetic base in the population of

sheep in the United States is such that the majority of slaughter labs would have optimal composition (i.e., the correct amount of fat by contemporary standards and for desires of present-day consumers) at live weights of less than 100 lb. Weight gains beyond that are largely due to deposition of fat. If the sheep industry is forced to dramatically increase leanness of its product, it has these choices: (a) change the genetics of the population by selecting directly for increased size and muscling; (b) slaughter market lambs at liveweights of 85 to 95 lb; (c) limit-feed lambs in the feedlot so that skeletal and musculature growth is maximized prior to deposition of carcass fat; or (d) use hormones, growth promotants, repartitioning agents and/or genetic engineering to modify body composition. Scientists at TAES (2, 4) have reported effects of using the repartitioning agent, clenbuterol, on growing-finishing lambs; they concluded that use of this beta-agonist increased ribeye area by 32 percent, improved leg conformation score by 48 percent and decreased subcutaneous fat covering (opposite the center of the ribeye) by 31 percent, but did not alter USDA quality grade. It seems obvious that the solution for the present over-fatness of the American lamb—if it must be accomplished quickly—rests in item (d), above, plus recognition that the problem of excessive fatness exists.

Realizing that lamb has not been singled out as a food to avoid by medical/dietetic professionals because it is a minor component of the American diet. There is considerable naivete among many in the industry regarding "why" lamb has not been targeted as a component of the diet that is to be avoided by those with diet/health concerns. Lamb is not less fat than other red meats. It is not lower in saturated fat or cholesterol content. It does not have some magical, mystical qualities that make it more safe or less dangerous to human health than beef or pork. It is not the equal of fish, for example, in its content of omega-3 fatty acids. As simply as we can express it—lamb consumption, per capita, in the U.S. is presently ~1.5 pounds (carcass weight basis) while consumption of beef (~76 pounds) and pork (~59 pounds) is 40 to 50 times as high.

No wonder lamb isn't singled out as a food to avoid by medical/dietetic professionals, it just is not eaten by enough consumers to make it a viable target. However, when knowledgeable professionals are asked about nutrient composition of lamb it does not receive a "clean bill of health." If the industry is eventually successful in increasing per capita consumption of lamb, its percentage of calories as fat will most certainly come to light and that will become an issue to informed medical/dietetic personnel and to the consumer. Action should be taken now to dampen the effect of such information becoming public knowledge and affecting consumer acceptability of lamb; appropriate immediate action would be to reduce fatness of the product.

Reacting to other meat and protein-source competition by making lamb products fit—not fight—the times. One of America's foremost researchers of consumer attitudes,

Florence Skelly, President of Yankelovich, Skelly and White, recently outlined a three-pronged program designed to help the red meat industry expand its market share in the very competitive protein market (3). Based on YSW surveys of consumer attitudes taken three times during the last 5 years, Skelly said the industry "must recognize the way consumer attitude is moving and take action in this very competitive market." She further recommends that the industry adopt an interlocking approach that would: (a) communicate to consumers the positive characteristics of meat, i.e., good taste, traditional role in the diet, etc.; (b) tailor the product to satisfy concerns about fitness and health, i.e., leaner, different size packages, pre-cooked, etc.; and (c) counter-attack health claims against meat by communicating with experts (3).

John Huston, President of the National Live Stock and Meat Board, has said (21) that "red meat producers should aim product development and promotion at people who 'graze' their food, including Yuppies and the millions of health-conscious and dieting Americans." He further stated that: (a) There is increasing demand for fast, convenient food by young urban professionals and others who "graze" throughout the day—snacking and browsing as opposed to dining; (b) the market we should aim for is the one-third of Americans with active lifestyles whose first consideration, when it comes to eating, is time and whose second consideration is the diet/health issue; (c) there is need to communicate to the public the nutritional value of red meat through factual advertising, promotion, and scientific seminars (he did note that promotion and communication alone are not enough; we must have the proper products for the market.); and (d) consumers do not necessarily buy on facts; they buy on attitudes and perceptions (21).

P. J. Cook, President of the American Sheep Producers Council, has said (11) that the three greatest needs of the lamb industry are as follows: (a) We need to keep our eye on fat. Nobody wants fat anymore. We have to be sensitive to consumer wants. (b) We need to get more lamb into the box; 90 percent of beef is going into the box. (c) New product development is expensive and risky, but we've had some successes, and they've been the most expensive. Consumers and big companies have welcomed help from the American Lamb Council. Pierre Franey, food columnist for the New York Times, recently concluded that "the sheep industry's duty is to give us a much leaner lamb (11)."

Among comments made during the 1985 Tall Timber Tour by packers and retailers (11) were the following. "We're getting some Choice, Yield Grade 2's and 3's from grass-fed lambs." "We might get to the point where packers will buy on yield on the rail. It's going to come to yield grading." "Packer brands with better quality control than the government may come." "As the industry evolves, to case-ready product, consumers won't pick up cuts with fat on them." "We're contracting our lambs now—and yield grading them. U.S.D.A. can yield grade now." Yield grading is an essential element in the Rocco Further Processing,

incorporated lamb program, both as a way of compensating the efficient producers and serving as a benchmark for the program (12).

An extremely critical means for improving shelf-life and storage stability of lamb, to allow its movement from geographical regions of production to primary areas (Northeast, Great Lakes Crescent, West Coast) of consumption, is packaging. Scientists at the Texas Agricultural Experiment Station have studied pre-cut, reformed, vacuum packaged lamb (22), use of vacuum vs. modified gas atmosphere packaging for lamb (1, 13,20), and packaging of lamb retail cuts in high oxygen-barrier film (5). Results of these studies have provided industry with several alternatives for protecting product in wholesale cut or retail cut forms. Rocco Further Processing, Incorporated reports (12) that with strict sanitation and prompt and adequate chilling, lamb cuts can be vacuum packaged and stored at 34°F for 40 days with excellent bloom retention and flavor preservation. Case-ready, tray-packed lamb is coming (11). Angel Pride in Vernon, California has it, fresh-chilled Australian product is here now, and New Zealand arrive shortly. Imitating and emulating what poultry has done with prepackaged retail products will help lamb fit—not fight—the times.

Although per capita consumption of lamb in the United States is presently 1.5 lb, people in New York City eat 8 lb per year. The 20 percent of lamb users who have entered the market in the last 5 years are young, affluent and, supposedly, attracted by lamb's taste, nutrition and health attributes (11). The American Lamb Council's fall advertising campaign—"Lean, light, luscious, limitless lamb"—is designed to attract young and affluent consumers. There is a need to introduce lamb to a lot of people, like those in Iowa (Iowa has more sheep producers—12,500—than any other state) who have never even tasted lamb (11). The American Lamb Council is presently working with the National Association of Meat Purveyors because 10,000 restaurants have asked how to prepare lamb (11).

The Better Homes and Gardens consumer survey in 1985 indicated the growing need for convenience in food products and preparation because of the increase in working housewives and in 1- or 2-member households; they found that 63 percent of consumers have microwave ovens and that 81 percent use them every day. The most recent Yankelovich, Skelly and White survey revealed that 36 percent of consumers said they rarely have time to fix meals that take more than 30 to 60 minutes to prepare. The poultry industry capitalized early on the need for convenient, quick-to-fix, meat meals—targeting usages and specific consumer segments. Lamb must emulate their successes in those ventures.

TAES scientists (9) reported recently on their progress with restructuring of lamb legs. They utilized defatted, de-sinewed muscles from the inside, outside and knuckle portions of the leg to make a very lean roast that has superb appearance, quality, and palatability attributes. These scientists have also produced

excellent restructured products—as fingers, nuggets, steakettes and roasts—using underutilized muscles from the shoulder and rough cuts. Technology is available to create a wide variety of convenient and microwaveable, restructured lamb products; missing at present is industry interest in capitalizing on such knowledge. That too will come.

The future for lamb is bright. Recognizing its shortcomings, building upon its strengths, and making it more convenient to prepare will make it fit—not fight—the times.

References

1. Christopher, F.M., Z.L. Carpenter, C.W. Dill, G.C. Smith, and C. Vanderzant. 1980. Microbiology of beef, pork and lamb stored in vacuum or modified gas atmospheres. *J. Food Protection*. 43:259.
2. Coleman, M.E., P.A. Ekeren, and S.B. Smith. 1985. Adipose tissue metabolism in sheep fed the repartitioning agent clenbuterol. *J. Anim. Sci.* Volume 61, Supplement 1, p. 264.
3. *Drovers Journal*. 1985. Researcher outlines market expansion plan. November 14 issue. The *Drovers Journal*, Shawnee, Mission, KS. p.22.
4. Hamby, P.L., J.R. Stouffer, and S.B. Smith. 1985. Muscle metabolism and carcass traits in lambs fed diets containing a beta-agonist. *J. Anim. Sci.* Volume 61, Supplement 1, p. 246.
5. Henry, K.G., J.W. Savell, G.C. Smith, J.G. Ehlers, and C. Vanderzant. 1983. Physical, sensory and microbiological characteristics of lamb retail cuts vacuum packaged in high oxygen-barrier film. *J. Food Sci.* 48:1719.
6. Jeremiah, L.E., J.O. Reagan, G.C. Smith, and Z.L. Carpenter. 1971. Ovine yield grades, I. Retail case-life. *J. Anim. Sci.* 33:759.
7. Jeremiah, L.E., G.C. Smith, and Z.L. Carpenter. 1972. Ovine yield grades. II. Palatability attributes within various quality grades. *J. Anim. Sci.* 34:196.
8. Johnston, D.D., W.E. Tyler, C.E. Murphey, E.F. Kimbrell, D.F. Manns, C.L. Strong, Z.L. Carpenter, and G.T. King. 1967. Estimating yields of retail cuts from lamb carcasses. *J. Anim. Sci.* 26:896 (Abstr.)
9. Keeton, J.T. and H.R. Cross. 1985. Leg of lamb processing. Special Report to National Livestock and Meat Board. Mimeograph. Tex. Agri. Expt. Sta., College Station, TX 77843.
10. Lin, K.C., H.R. Cross, H.K. Johnson, B.C. Breidenstein, and J.K. Ono. 1986. Nutrient composition of U.S. and New Zealand lamb. *J. of Food Sci.* (In Press)
11. National Provisioner. 1985a. Lamb is breaking into limelight. October 19, 1985 issue. The National Provisioner, Chicago, IL. pp. 16-71.
12. National Provisioner. 1985b. Poultry firm aims toward integrated lamb meat production. November 2, 1985 issue. The National Provisioner, Chicago, IL. pp. 6-20.
13. Seideman, S.C., C. Vanderzant, G.C. Smith, C.W. Dill, and Z.L. Carpenter. 1980. Appearance of beef, pork and lamb stored in vacuum or modified gas atmospheres. *J. Food Protection*. 43:252.
14. Smith, G.C. and Z.L. Carpenter. 1970. Lamb carcass quality. III. Chemical, physical and histological measurements. *J. Anim. Sci.* 31:697.
15. Smith, G.C. and Z.L. Carpenter. 1973. Estimations of lamb carcass cutability within narrow ranges of weight and fat thickness. *J. Anim. Sci.* 36:432.
16. Smith, G.C., Z.L. Carpenter, and G.T. King. 1969a. Ovine carcass cutability. *J. Anim. Sci.* 29:272.
17. Smith, G.C., Z.L. Carpenter, G.T. King, and K.E. Hoke. 1969b. Lamb palatability studies. *Proc. Recip. Meat Conf.* 22:69.
18. Smith, G.C., Z.L. Carpenter, G.T. King, and K.E. Hoke. 1970a. Lamb carcass quality. I. Palatability of leg roasts. *J. Anim. Sci.* 30:496.
19. Smith, G.C., Z.L. Carpenter, G.T. King and K.E. Hoke. 1970b. Lamb carcass quality. II. Palatability of rib, loin and sirloin chops. *J. Anim. Sci.* 31:310.
20. Smith, G.C., S.C. Seideman, J.W. Savell, C.W. Dill, and C. Vanderzant. 1983. Vacuum packaging versus modified atmosphere packaging of lamb loins. *J. Food Protection*. 46:47.
21. *St. Joseph Journal*. 1985. Meat officials say aim beef market at "yuppies". November 15, 1985 issue. *St. Joseph Journal of Livestock and Agriculture*, St. Joseph, MO. p. 7.
22. Tatum, J.D., G.C. Smith, and Z.L. Carpenter. 1978. Storage life of pre-cut, reformed, vacuum packaged lamb loins. *J. Food Sci.* 43:1327.
23. USDA. 1969. Official United States Standards for grades of lamb, yearling mutton and mutton carcasses. USDA-AMS, Washington, D.C.
24. USDA. 1982. Official United States Standards for grades of lamb, yearling mutton and mutton carcasses. USDA-AMS, Washington, D.C.

Acknowledgement

Support of lamb carcass research at the Texas Agricultural Experiment Station by the Natural Fibers and Food Protein Commission of Texas is gratefully acknowledged.

PR-4406

Carcass Composition of Lambs From the United States and New Zealand

K.C. Lin, H.R. Cross, and H.K. Johnson

Summary

Compositional comparisons involving 24 lamb carcasses from the United States and 27 lamb carcasses

from New Zealand were conducted. The U.S. lambs were from feedlots in Texas, Colorado and Montana and were of four age groups and of two quality grades. The New Zealand carcasses were from wether and ewe lambs of three breed types (Romney, Romney X Border, and Romney X Border X Dorset), of three carcass weight groups and ranged in age from 7 to 8 months. The middle weight group represented the typical New Zealand lamb carcass exported to the United States, while the other two weight groups were selected to represent extremes on either side of the "typical" group. U.S. lambs were heavier, had larger ribeyes, more outside fat, and higher percentages of lean, fat and total edible tissue, but had less bone and connective tissue than New Zealand lambs.

Introduction

U.S. sheep production systems have changed dramatically over the past 20 years. Intensive breeding pressure and improved nutrition and management practices have resulted in the production of faster growing, larger lambs with less fat. To reflect these changes, the USDA grade standards have been changed three times (1960, 1969, and 1982)(2). Lamb and Mutton production has increased from 284 million pounds in 1979 to 368 million pounds in 1983. In addition to the domestic supply, about 26 million pounds of lamb and mutton were imported and consumed in the United States in 1983 (3). Since handling and production practices differ in the United States and New Zealand, the potential exists for differences in composition. There is a lack of knowledge of how this potential difference in management and breeding may contribute to the total edible meat of lambs imported from New Zealand. The objective of this study was to provide a clearer picture of actual composition of lambs produced in the United States and New Zealand.

Experimental Procedure

Twenty-four U.S. lamb carcasses and 27 New Zealand lamb carcasses were randomly selected for use in this study. In order to make certain that lambs used in this study represented the typical U.S. lamb, animals

from different ages (5 to 11 months); sexes (ewes and wethers); geographic locations (Texas, Colorado and Montana); and USDA quality grades (Prime and Choice) were selected. Lambs from each location were identified, slaughtered and dressed according to conventional commercial practices. After processing, the carcasses were graded according to USDA quality and yield grade standards (2). One purebred (Romney) and two crossbreeds (Romney X Border Leicester and Romney X Border Leicester X Dorset) lambs from four different New Zealand farms were selected for use in this study. Lambs were slaughtered and dressed according to New Zealand commercial slaughter practices with kidney, tail, metatarsal bone, and kidney, pelvic and heart fat removed. The carcass data and USDA carcass grade traits were obtained for each dressed carcass (Table 2). The typical New Zealand lamb presently being shipped to the United States falls into the 30 to 33 lb weight range. In this study, carcasses were selected to represent three weight/grade groups. Group I (YL, 25 to 28 lb) and Group III (PX, 37 to 40 lb) represented extremes on either side of the "typical" group (Group II, PM, 30 to 33 lb) presently being exported to the United States. Carcasses were identified, packaged and shipped frozen as intact carcasses to the United States.

All carcasses were shipped by refrigerated vehicle to the Texas A&M University Meat Science and Technology Center for further processing. Alternating sides from each carcass were weighed, recorded, and fabricated into retail cuts as identified in the Uniform Retail Meat Identity Standards (1). Retail cuts were trimmed to a maximum of ¼ inch of subcutaneous fat. The shoulder and loin were fabricated into ¾ inch thick arm, blade and loin chops. The rack, with short rib removed, was separated between the 10th-11th rib into blade-end and rib-end portions.

Except for the minor cuts (neck, flank, breast, and flank-edge), and the trimmings from the shoulder and short-rib, retail cuts were dissected into fat (subcutaneous fat, intermuscular fat, and kidney, pelvic and heart fat); lean; bone; and connective tissue. The tissue from each retail cut was weighed and recorded separately

Table 1. Mean U.S. carcass traits segregated by age groups and USDA quality grades

Carcass trait	Texas feed-lot lambs				Colorado feed-lot lambs		Montana mountain grass fed lambs	
	7-month		11-month		9-11 month		5-7 month	
	Prime	Choice	Prime	Choice	Prime	Choice	Prime	Choice
Chilled carcass wt. (lb)	51.92	51.02	58.30	57.60	56.83	54.87	58.70	55.20
Overall maturity score	A°	A°	A°	A+	A°	A+	A°	A°
Flank streaking	P-	Ch-	P°	Ch°	P-	Ch-	P-	Ch-
USDA quality grade	P°	Ch°	P-	Ch°	P-	Ch°	P-	Ch°
Leg conformation score	Ch+	Ch+	P°	P-	P°	Ch+	P-	Ch+
Ribeye area (in ²)	1.88	1.89	2.08	2.15	1.95	2.04	2.36	2.11
Fat thickness over ribeye (in.)	.25	.25	.30	.25	.21	.23	.39	.24
Kidney, pelvic and heart fat (%)	3.75	2.88	3.00	5.50	5.75	4.25	4.00	4.13
USDA yield grade	3.60	3.45	3.75	4.13	3.80	3.68	4.65	3.68

and reconciled back to the original retail cut weight. Minor cuts and the trimmings were dissected into soft tissue, bone, and connective tissue, and the dissection weight data were recorded separately.

Results and Discussion

Data presented in Tables 1 and 2 indicate that U.S. lambs had heavier carcasses, larger ribeyes and more fat over the ribeye than New Zealand lambs. The USDA quality grade of the U.S. lambs ranged from average Choice to average Prime, while the USDA quality grade for New Zealand lambs ranged from low to average Choice.

U.S. lambs had higher percentages of lean, fat, and total edible tissue, but had less bone and connective tissue as compared to the lighter weight New Zealand carcasses (Table 3). U.S. and New Zealand lambs did not differ significantly in percentage of retail cuts. Total minor cut yield was lower in U.S. lambs; however, the soft tissue percentage between the U.S. and New Zealand lambs did not differ ($P>.05$). Total plate waste did not differ between U.S. and New Zealand lambs. It is likely that the higher fat content of the U.S. lambs was off-set by the higher bone and connective

tissue content of the New Zealand lambs. The higher bone and connective tissue content of the New Zealand lambs is probably a reflection of their stage of maturity (light weight carcasses and lower muscle to bone ratio). Thus, it appears that the U.S. lamb carcass can yield a higher percentage of trimmed edible product. One of the most serious problems facing the lamb industry today is the negative consumer image of the product. This negative image is enhanced by the amount of fat on lamb products in the meat case. There is no room for excess fat on lamb products in the retail case. The lamb industry must reduce on fat in order to improve the image of their product.

Literature Cited

1. National Live Stock and Meat Board. 1973. Uniform Retail Meat Identity Standards. Chicago, IL.
2. USDA. 1982. Official United States standards for grades of lamb, yearling mutton, and mutton carcasses. Agricultural Marketing Service, Washington, D.C.
3. USDA. 1983. "Livestock and Meat Statistics". Economic Research Service, Statistical Bulletin, No. 715, Washington, D.C.

Table 2. Mean carcass traits for New Zealand lambs

Carcass trait	Carcass group ^a		
	YL (25-28 lb)	PM (30-33 lb)	PX (37-40 lb)
Hot carcass weight (lb)	25.92	30.93	37.40
Carcass maturity ^b	2.0	2.0	2.3
Flank streaking	Ch ^o	Ch ^o	Ch ⁺
Ribeye area (in ²)	1.15	1.38	1.60
Fat thickness over ribeye (in.)	.12	.20	.19
USDA quality grade	Ch ⁻	Ch ⁻	Ch ^o

^aCarcasses were grouped by carcass weight and New Zealand grade (YL, PM and PX).

^bYoung = 1-3; More mature = 4-6 (actual age of all lambs were in the 7 to 8 month range).

Table 3. Comparison of the carcass composition of lambs from the United States and New Zealand

Retail cut item	U.S. Lambs	New Zealand Lambs
Carcass wt., lb.	55.18 ^a	31.92 ^b
Total primal retail cuts, %	66.96 ^a	66.02 ^a
Total minor cuts, %	25.66 ^a	28.84 ^b
Lean, %	37.92 ^a	35.34 ^b
Soft tissue, %	23.98 ^a	23.55 ^a
Fat, %	17.59 ^a	12.80 ^b
Bone + connective tissue, %	19.27 ^a	23.44 ^b
Total edible tissue, %	61.90 ^a	58.88 ^b
Total plate waste ^c , %	36.86 ^a	36.24 ^a

^{a,b}Means within a row followed by different letters differ significantly ($P<.05$).

^cTotal plate waste included fat, bone and connective tissue.

PR-4407

Nutrient Composition of U.S. and New Zealand Lamb

K.C. Lin, H.R. Cross, and H.K. Johnson

Summary

The nutrient composition of U.S. and New Zealand lambs was studied. Separable lean tissue of major retail cuts from lambs (24 U.S. lambs and 27 New Zealand lambs) differing in age, sex, quality grade, and weight were analyzed for differences in nutrient composition. Retail cut had significant effects on the proximate nutrient composition of the U.S. lambs, but had no significant effect on the ash content of the New Zealand lambs. Rib roasts from both U.S. and New Zealand lambs had higher levels of fat and less moisture than the remaining cuts. Moisture and ash contents generally were lower in U.S. lambs, while intramuscular fat content was lower in New Zealand lambs. However, the protein content between the U.S. and New Zealand lambs was not different. Cholesterol levels in New Zealand lambs varied from 79.8 mg/100 g in loin chops to 71.36 mg/100 g in shoulder cuts. These values are 10 to 20 percent higher than reported values for lean from U.S. lamb. The ratio of polyunsaturated and saturated fatty acids was significantly higher in the leg than the other three cuts. Although the content of most vitamins differed from

cut to cut, thiamin, vitamin E, and folacin did not show significant differences among the four cuts.

Introduction

Although a segment of the population consumes lamb and mutton (4), there is little knowledge of its nutrient composition. The declining image of red meat products due to the increasing consumer concern about the nutrient composition of these products is having a significant impact on their per capita consumption (2). USDA Handbook No. 8 (1963) (7), revised two decades ago, is the only data source for nutrient composition of lamb. Handbook No. 8 does not include any data which reflects the effects of the changes in USDA quality grade and production practices over the past two decades.

About 10 percent of the lamb and mutton consumed in the United States is imported (6). Of that 10 percent, approximately 90 percent is imported from New Zealand. Since handling and production practices differ between the United States and New Zealand, and because the variation in the management systems between the two countries may result in differences in nutrient composition, it is important to establish the nutrient profile of New Zealand lambs.

Although a classical study (4) was conducted recently on the nutrient composition of cooked and raw domestic lamb meat, samples in that study were limited to only one quality grade (Choice), two age groups and one region of the country. Geographical region and USDA quality grade could also have a significant effect on nutrient composition. Thus, this study was designed to investigate nutrient composition of lambs from various age groups, USDA quality grades, geographical regions, and different countries.

Experimental Procedure

Twenty-four U.S. lamb carcasses and 27 New Zealand lamb carcasses were randomly selected for use in this study. Lamb carcass selection was designed to make certain that the carcasses selected represented the typical U.S. and New Zealand lambs consumed in the United States. U.S. lambs were selected from different ages (5 to 11 months), geographic locations (Texas, Colorado, and Montana) and USDA quality grades (Prime and Choice). Lambs from three breed types (Romney, Romney x Border, and Romney x Border x Dorset), three carcass weight groups and from ages ranging from 7 to 8 months were selected to represent the New Zealand lambs. Lambs from both the United States and New Zealand were slaughtered and dressed according to conventional commercial practices. New Zealand carcasses were shipped frozen as intact carcasses to the United States.

Alternating sides were fabricated into retail cuts as identified in the Uniform Retail Meat Identity Standards (3). Retail cuts were dissected into lean, fat, bone, and connective tissue. The samples were subjected to proximate nutrient analyses for both U.S. and New Zealand tissues. Fatty acid and vitamin analyses were conducted only on the New Zealand samples (loin chops, rib roast, leg, and shoulder). AOAC

methods (1) were used to quantitate moisture, protein, ash, fat, and vitamin (vitamin B₆, niacin, vitamin B₁₂, folacin, pantothenic acid, tocopherol, thiamin, and riboflavin). Fatty acids were quantitated by using the method reported by Slover and Lanza (5), while cholesterol was quantitated by gas liquid chromatography (4).

In order to compare the nutrient composition difference in each retail cut between the U.S. and New Zealand lambs, data from shoulder cuts (arm chops and blade chops) and leg (shank and sirloin) were pooled and adjusted for the U.S. lambs.

Results and Discussion

Mean proximate nutrient composition of the separable lean from the U.S. and New Zealand lambs are described in Table 1. As expected, there was more variation between retail cuts within a carcass than between carcasses. In general, U.S. lambs contained more intramuscular fat and consequently less moisture than New Zealand lambs. Since the fat and moisture was a trade-off, the protein content between U.S. and New Zealand lamb did not differ. The values of total unsaturated and saturated fatty acids in New Zealand lambs are in agreement with those of U.S. lambs reported by other researchers (4,7), but the ratio of polyunsaturated/saturated fatty acids was lower in New Zealand lambs numerically (Table 2). This disagreement might indicate that New Zealand lambs had relatively lower polyunsaturated fatty acids in lean tissue than the lean tissue of the U.S. lambs. Reflecting its higher fat content (Table 1), the rib roast showed higher total unsaturated and saturated fatty acid values on per 100g lean tissue basis as compared to the other cuts in New Zealand lambs (Table 2). Similar to the previous report (4), the ratio of polyunsaturated to saturated fatty acids in this study was also found to be higher in the leg than in the other three retail cuts. Cholesterol levels among the four cuts were higher in loin chops than in the leg and the shoulder cuts (Table 2). The cholesterol values of the New Zealand lambs presented in this study were approximately 10 to 20 percent higher than those of the U.S. lambs (64-66 mg/100g) reported recently (4).

Vitamin values for the separable lean tissue of New Zealand lamb are presented in Table 3. The values varied among cuts; however, no significant difference was observed in thiamin, tocopherol, and folacin. Although there were several significant differences in the vitamin contents between cuts, these differences were very small and would not likely have any practical significance. Most of the values presented in Table 3 agree with those reported previously (4), except folacin which was "not detectable" in this study.

In summary, separable lean of the rib roast in both U.S. and New Zealand lambs generally contained higher levels of extractable fat but had a lower moisture and ash content than the lean tissue of other cuts. The New Zealand cuts had a higher moisture and ash content and a lower fat content than the U.S. lean but the protein content between the two groups of cuts did

Table 1. Comparison of proximate nutrient values of separable lean from U.S. and New Zealand lambs segregated by retail cuts (age, grade and weight groups combined)

Nutrient	Lamb source	Retail cut				
		Loin chops	Rib roast	Leg (shank & sirloin)	Shoulder (arm & blade chops)	Fore-shank
Protein (%)	U.S.	21.07 ^a	19.82 ^a	20.51 ^a	19.80 ^a	21.05 ^a
	New Zealand	21.24 ^a	20.23 ^a	20.77 ^a	20.01 ^a	20.77 ^a
Fat (%)	U.S.	6.44 ^a	10.96 ^a	5.03 ^a	6.68 ^a	3.39 ^a
	New Zealand	4.61 ^b	5.93 ^b	3.83 ^b	5.63 ^b	2.98 ^a
Moisture (%)	U.S.	71.59 ^a	68.75 ^a	72.90 ^a	72.43 ^a	74.59 ^a
	New Zealand	73.14 ^b	72.70 ^b	74.17 ^a	72.57 ^a	76.08 ^b
Ash (%)	U.S.	1.05 ^a	0.99 ^a	1.06 ^a	1.05 ^a	1.06 ^a
	New Zealand	1.12 ^b	1.07 ^b	1.11 ^b	1.07 ^a	1.10 ^a

^{ab}Means within a column and within each nutrient followed by different letters differ significantly ($P < .05$).

Table 2. Mean fatty acid and cholesterol values of separable lean from New Zealand lambs segregated by retail cuts (weight groups combined)

Fatty acids	Retail cut			
	Loin chops	Rib roast	Leg (shank & sirloin)	Shoulder (arm & blade chops)
Cholesterol (mg/100g)	79.82 ^a	76.83 ^{ab}	73.16 ^{bc}	71.36 ^c
Total unsaturated fatty acid (g/100g)	1.79 ^{ab}	2.53 ^c	1.47 ^a	2.20 ^{bc}
Total saturated fatty acid (g/100g)	1.71 ^a	2.36 ^b	1.29 ^c	1.99 ^{ab}
Polyunsaturated/saturated	0.12 ^a	0.12 ^a	0.15 ^b	0.13 ^a

^{abc}Means within a row followed by different letters differ significantly ($P < .05$).

^dPolyunsaturated/saturated = total polyunsaturated fatty acids/total saturated fatty acids.

Table 3. Mean vitamin values of separable lean from New Zealand lambs segregated by retail cuts (weight groups combined)

Vitamin	Retail cut			
	Loin chop	Rib roast	Leg (shank & sirloin)	Shoulder (arm & blade chops)
Niacin (mg/100g)	7.06 ^a	6.11 ^b	6.62 ^{ab}	4.84 ^c
Thiamin (mg/100g)	0.15 ^a	0.14 ^a	0.16 ^a	0.14 ^a
Riboflavin (mg/100g)	0.37 ^{ab}	0.33 ^b	0.42 ^a	0.37 ^{ab}
Vit B ₆ (mg/100g)	0.15 ^a	0.11 ^b	0.14 ^a	0.10 ^b
Vit B ₁₂ (mcg/100g)	2.27 ^a	2.45 ^a	2.65 ^a	3.40 ^b
Pantothenic acid (mg/100g)	0.47 ^{ab}	0.44 ^b	0.49 ^{ab}	0.53 ^a
Vitamin E (mg/100g)	1242.3 ^a	1207.1 ^a	1206.9 ^a	1194.9 ^a

^{abc}Means within a row followed by different letters differ significantly ($P < .05$).

not differ ($P > .05$). The polyunsaturated and saturated fatty acid ratio indicated that New Zealand lamb may have a lower level of polyunsaturated fatty acids as compared to the U.S. lamb (4). Cholesterol level varied from cut to cut with the contents ranging from 79.82 mg/100g (loin chops) to 71.36 mg/100g (shoulder cuts). These values were 10 to 20 percent higher than previously reported for U.S. lamb (4).

Literature Cited

1. AOAC. 1980. Official methods of analysis. 13th ed. Assoc. of Official Analytical Chemists. Washington, D.C.
2. Breidenstein, B.C. 1984. Red meat: nutrient composition and actual consumption. National Live Stock and Meat Board, Chicago, IL.
3. National Live Stock and Meat Board. 1973. Uniform Retail Meat Identity Standards. Chicago, IL.
4. Ono, K., B.W. Berry, H.K. Johnson, E. Russek, C.F. Parkes, V.R. Cahill, and P.G. Althouse. 1984. Nutrient composition of lamb of two age groups. *J. Food Sci.* 49:1233.

5. Slover, H.T. and E. Lanza. 1979. Quantitative analysis of food fatty acids by capillary gas chromatography. *J. Am. Oil Chem. Soc.* 56(12):933.
6. USDA. 1983. *Livestock and Meat Statistics*. Economic Research Service, Statistical Bulletin, No. 715, Washington, D.C.f
7. Watt, B.K. and Merrill, A.L. 1963. *Composition of foods, raw, processed and prepared*. Agricultural Handbook No. 8. Consumer and Food Economics Research Division, Agricultural Research Service (current organization: Human Nutrition Information Service), USDA.

PR-4408

Evaluation of the Efficacy of Rumensin® for Controlling Coccidiosis in Angora Goats

B.C. Baldwin, Jr., M.C. Calhoun,
R.L. Huey, and T.M. Craig

Summary

Monensin (Rumensin®¹) was effective at a level of 10 g/ton of diet in reducing the number of fecal coccidial oocysts resulting from an initial, natural infection and in preventing a rise in fecal oocysts after Angora kid goats were orally challenged with 20,000 sporulated oocysts. The predicted optimum level of monensin for improvement of live weight gains varied from 16.4 to 17.5 g/ton of diet, and the predicted optimum level for improvement of feed intake varied from 13.4 to 15.7 g/ton of diet. At two of three field locations, 10 g monensin/ton of diet controlled the rise in fecal coccidial oocyst numbers, and 20 g/ton controlled the rise in oocyst numbers at all locations. In the field trials monensin increased average daily gains and feed intakes, and in this regard, 10 g/ton appeared as effective as 20 g/ton of diet.

Introduction

Coccidiosis, a disease caused by large numbers of protozoan parasites called coccidia is a serious problem that limits the performance of Angora goats. Kids kept in close confinement under unsanitary and (or) stress conditions such as weaning, shearing, travel and change of diets are particularly susceptible to coccidiosis (4). Large numbers of coccidial oocysts may be found in the feces of infected animals. Clinical signs include loss of weight, diarrhea and unthriftiness.

Monensin has been shown to be an effective coc-

cidostat when included in sheep diets (1,2), and preliminary studies have demonstrated its efficacy as a coccidiostat for goats (3). The purpose of this study was to provide information on the efficacy of monensin for treating experimentally induced (dose-titration study) and naturally occurring (field studies) coccidial infections in Angora goats.

Experimental Procedures

The dose-titration study was conducted at the Texas A&M University Agricultural Research and Extension Center at San Angelo, Texas, with 120 castrated Angora kid goats maintained in 24 pens containing 5 goats each.

A 20-day preliminary period was used to allow the goats to adapt to their new surroundings and diet (Table 1). The diet was initially restricted to .5 lb per goat per day and then increased daily until full feed was achieved.

Following the preliminary period, all goats were started on the monensin diets. Five levels of monensin² were used (0, 5, 10, 20 and 30 g/ton of diet, as fed basis). Four pens received each monensin level, and four additional pens were selected to receive the diet with no monensin and serve as uninoculated controls.

Sixteen days after the start of monensin feeding (dose-titration study), all of the goats to be inoculated were orally inoculated with 20,000 sporulated coccidial oocysts.

The field studies were conducted at the Joe David Ross Ranch (Ross Ranch), Sutton County; the Texas A&M University's Agricultural Research Station (Sonora Ranch), Edwards County; and the Texas A&M University's Agricultural Research and Extension Center (San Angelo), Tom Green County.

The Angora kid goats used for the field studies were a mixture of females and castrated males. Sixty kid goats were selected from both the Ross Ranch and San Angelo and maintained in 3 pens containing 20 goats each balanced with respect to sex. Sixty-eight kid goats were used at the Sonora Ranch maintained in 3 pens containing 20, 23 and 24 goats respectively.

The field studies did not include a preliminary period, because the goats were familiar with the facilities; however, they were started on feed in the same manner as the goats used for the dose-titration study. Three levels of monensin were used (0, 10 and 20 g/ton of diet, as fed basis). Each ranch had one pen of goats on each of the monensin diets.

The monensin feeding period (experimental period) for both studies was 56 days in duration. During this time, the diets were fed daily, and feed refusals were collected at 7-day intervals.

During the experimental period (both studies), observations for clinical signs of coccidiosis were made daily. Fecal samples for determination of coccidial oocyst numbers were collected from representative goats in each treatment group initially and every 14

¹Rumensin® - monensin sodium, a product of Eli Lilly and Company, Indianapolis, Indiana 46206 is an experimental drug and is not approved for use with Angora goats.

²Rumensin®- Lot No. 5MD 56, Shipment No. 83213 containing 60 g of monensin sodium per pound of premix was used to make the experimental diets.

days thereafter until the end of the experimental period.

Results and Discussion

Initially, all the goats sampled were shedding coccidial oocysts in their feces. However, there was considerable animal to animal variation as evidenced by the

Table 1. Ingredient and nutrient composition of the basal diet

Ingredient	IFN ^a	% in diet
Sorghum grain, milo ^b	4-04-444	46.5
Dehydrated alfalfa meal	1-00-025	10.0
Peanut hulls	1-08-028	20.0
Cottonseed meal, 41% crude protein	5-01-621	15.0
Sugarcane molasses	4-04-696	6.0
Vitamin-mineral premix ^c	—	2.5
Nutritional values ^d		
Dry matter, %		89.6 ± .4
Crude protein, %		17.4 ± .4
Acid detergent fiber, %		28.6 ± 1.4
Calcium, %		.84 ± .07
Phosphorus, %		.39 ± .01
Magnesium, %		.19 ± .003
Potassium, %		1.38 ± .02
Copper, ppm		5.9 ± .14
Manganese, ppm		28.6 ± 1.17
Zinc, ppm		48.1 ± 2.12

^aInternational Feed Number.

^bDry rolled.

^cCalcium carbonate, 42.872%; salt, 28.531%; ammonium sulfate, 19.510%; potassium chloride, 7.754%; zinc oxide, .1875%; manganese oxide, .1318%; vitamin A (30,000 IU/g), .2889%; vitamin D₃ (200,000 IU/g), .00507%; vitamin E (275.6 IU/g), .7196%.

^dValues are on a dry matter basis.

range in oocyst values reported in Tables 2 and 3. The effect of confinement on coccidiosis problems in Angora kid goats was apparent from the increase in oocyst numbers during the first 14 days the control goats were kept in confinement.

In the dose-titration study, oocyst numbers decreased for all monensin treatments during the first 14-day period; however, this was followed by an increase in oocyst numbers in the goats receiving 5 g of monensin/ton of diet. This indicated the 5 g/ton level was not adequate to control coccidial infections in Angora kid goats. Ten grams of monensin per ton appeared as effective as 20 and 30 g/ton in reducing the number of oocysts resulting from the initial natural infection and in preventing a rise after the goats were inoculated with 20,000 sporulated coccidial oocysts (Table 2).

At two of the three field locations 10 g of monensin per ton controlled the rise in oocyst numbers, and 20 g/ton controlled the rise at all locations (Table 3). Based on these results, the optimum amount of monensin required to control coccidiosis in Angora kid goats is between 10 and 20 g/ton of complete diet. The safest procedure would be to use 20 g/ton.

The effects of monensin on performance of the kid goats in the dose-titration study are presented in Table 4. Monensin produced significant quadratic effects on live weight gains and feed intakes by 28 days, and these effects continued throughout the experimental period. The predicted optimum level of monensin for improvement of live weight gains varied from 16.4 to 17.5 g/ton of diet (as fed basis), and the predicted optimum values for improvement of feed intake varied from 13.4 to 15.7 g/ton of diet. In the field trials, monensin increased average daily gains and feed intakes, and in this regard, 10 g/ton appeared as effective as 20 g/ton of diet (Table 5).

Table 2. Summary of effects of monensin on fecal coccidial oocyst numbers of castrated, male Angora kid goats experimentally infected with 20,000 sporulated coccidial oocysts

Sample time (days)	Item	Non-inoculated control	Inoculated control	Monensin, g/ton			
				5	10	20	30
0	Goats, No.	8	8	7	8	8	8
	Ave. oocysts/g (X10 ³)	12.3	4.9	12.3	25.9	10.2	22.9
	Range oocysts/g (X10 ³)	2.5-47.8	.9-13.6	.5-58.3	1.1-126.3	2.0-31.1	1.5-78.6
14	Goats, No.	8	8	7	8	7	8
	Ave. oocysts/g (X10 ³)	311.1	47.6	8.3	5.5	6.1	5.4
	Range oocysts/g (X10 ³)	1.0-1,151.2	4.0-165.0	.3-26.3	0-31.1	.3-27.8	0-32.7
28	Goats, No.	8	8	7	8	7	8
	Ave. oocysts/g (X10 ³)	51.8	45.9	11.4	1.1	2.4	5.1
	Range oocysts/g (X10 ³)	3.9-185.8	1.8-198.9	.3-50.1	0-5.6	0-9.5	0-23.5
42	Goats, No.	5	7	7	8	6	8
	Ave. oocysts/g (X10 ³)	15.8	41.3	55.7	3.4	1.5	.4
	Range oocysts/g (X10 ³)	2.7-48.6	3.6-134.8	1.0-361.0	.1-15.7	0-6.2	0-1.6
56	Goats, No.	5	7	7	8	6	8
	Ave. oocysts/g (X10 ³)	9.4	6.4	20.6	1.8	.3	.8
	Range oocysts/g (X10 ³)	1.3-24.4	1.0-11.1	.5-135.6	0-9.2	0-1.1	0-1.9

Table 3. Effects of monensin on fecal coccidial oocyst numbers of Angora kid goats naturally infected with coccidia at three field locations

Criterion	Ross Ranch			San Angelo			Sonora Ranch		
	monensin, g/ton			monensin, g/ton			monensin, g/ton		
	0	10	20	0	10	20	0	10	20
0 days									
Ave. oocysts/g (X10 ³)	2.5	4.8	8.2	8.9	.6	26.0	2.1	.9	11.0
14 days									
Ave. oocysts/g (X10 ³)	140.0	1.2	.4	24.6	9.6	.7	5.1	90.2	6.1
28 days									
Ave. oocysts/g (X10 ³)	33.3	.3	.1	80.3	.4	.4	98.6	2.0	2.2
42 days									
Ave. oocysts/g (X10 ³)	45.0	.7	.1	50.3	.3	.1	244.5	42.8	3.1
56 days									
Ave. oocysts/g (X10 ³)	77.4	.3	.1	728.9	.7	.1	33.3	4.6	.6

Table 4. Effects of monensin on performance of castrated, male Angora kid goats experimentally infected with 20,000 sporulated coccidial oocysts

Criterion	Non-inoculated control	Inoculated control	Monensin level, g/ton				Statistical ^a comments
			5	10	20	30	
Initial live weight, lb	42.1	42.5	44.1	42.8	41.0	41.0	N.S.
1-14 days							
Live weight gain, lb/d	.110	.196	.225	.278	.198	.190	N.S.
Feed intake, lb/d	1.17	1.43	1.43	1.46	1.46	1.17	N.S.
1-28 days							
Live weight gain, lb/d	.049	.119	.229	.335	.267	.203	Q,P<.01
Feed intake, lb/d	1.12	1.43	1.59	1.63	1.63	1.30	Q,P<.05
1-42 days							
Live weight gain, lb/d	.057	.064	.205	.326	.276	.214	Q,P<.01
Feed intake, lb/d	1.08	1.32	1.59	1.72	1.79	1.37	Q,P<.01
1-56 days							
Live weight gain, lb/d	.000	.035	.106	.198	.196	.126	Q,P<.01
Feed intake, lb/d	1.10	1.39	1.63	1.85	1.90	1.46	Q,P<.01

^aN.S. = No significant differences among treatments means; Q = Significant quadratic response (non-inoculated control was not included in the statistical analysis).

Table 5. Effects of monensin on live weight gains and feed intakes of Angora kid goats naturally infected with coccidia at three field locations

Criterion	Ross Ranch			San Angelo			Sonora Ranch		
	monensin, g/ton			monensin, g/ton			monensin, g/ton		
	0	10	20	0	10	20	0	10	20
Initial live weight, lb	37.5	37.0	35.5	41.0	44.3	40.6	34.0	36.8	38.1
1-28 days									
Live weight gain, lb/d	.154	.326	.280	.106	.289	.269	.112	.150	.174
Feed intake, lb/d	1.84	2.26	1.83	1.39	1.60	1.63	2.14	1.80	2.13
1-56 days									
Live weight gain, lb/d	.163	.337	.271	.123	.284	.258	.071	.168	.216
Feed intake, lb/d	1.80	2.36	2.07	1.44	1.93	1.94	1.76	1.90	2.15

Literature Cited

1. Bergstrom, R.C. and L.R. Maki. 1976. Coccidiostatic action of monensin fed to lambs: body weight gains and feed conversion efficiency. *Amer. J. Vet. Res.* 37:79.
2. Calhoun, M.C., L.H. Carroll, C.W. Livingston, Jr., and J.M. Shelton. 1979. Effect of dietary monensin on coccidial oocyst numbers, feedlot performance and carcass characteristics of lambs. *J. Anim. Sci.* 49:10.
3. Shelton, M., P. Thompson, and C. Snowden. 1982. Effect of monensin and sulfamethazine on performance and naturally occurring coccidiosis in kid goats. *Southwest. Vet.* 35:27.
4. Yvone, P., P. Dupre, A. Esnault, and J. Besnard. 1980. Experimental coccidiosis in the young goat: parasitic development and lesions. *Int. Goat and Sheep Res.* 1(2):163.

Acknowledgements

This research was conducted under a memorandum of agreement between the Texas Agricultural Experiment Station of the Texas A&M University System and Rutgers University/New Jersey Agricultural Experiment Station, IR-4 Project. Partial support was provided by the IR-4 Project. The cooperation of Dr. Joe David Ross and Don Spiller in assisting with the field trials is appreciated.

PR-4409

Safety of Rumensin® as a Coccidiostat for Angora Goats

B.C. Baldwin, Jr., M.C. Calhoun,
T.M. Craig, and L.P. Jones

Coccidiosis, a disease caused by a protozoan parasite called coccidia, is a serious problem that limits performance of Angora goats. Monensin¹ has been shown to be an effective coccidiostat when added to goat diets at levels of 10 to 20 g/ton. Twenty castrated Angora kid goats were used in a study to determine the toxicity of monensin. They were fed, ad libitum, a diet designed to meet or exceed the nutritional requirements of growing Angora kid goats. After a 2-week preliminary period, they were randomly assigned to the following treatments (four goats per treatment): control - no monensin; 25 g monensin/ton diet; 50 g monensin/ton

¹Rumensin® - monensin sodium, a product of Eli Lilly and Company, Indianapolis, Indiana 46206, is not approved for use with goats. The Rumensin® premix contained 60 g of monensin sodium per pound.

diet; 75 g monensin/ton diet; and 100 g monensin/ton diet. The duration of the treatment feeding period was 56 days. Weekly live weights were recorded, daily feed records were maintained and observations were made for clinical signs of monensin toxicity. Blood samples were also taken for analysis. The animals were slaughtered at the end of the study and tissue samples collected for histopathological examination.

The only apparent effects of feeding monensin were reductions in live weight gains and feed intakes of goats fed 75 and 100 g of monensin/ton of feed. There were no changes in any of the blood constituents measured, no clinical signs of monensin toxicosis, and no lesions found in any of the tissues in goats fed the diet containing 100 g monensin/ton; (a level 5 to 10 times that found to be effective in controlling coccidiosis in Angora kid goats (10 to 20 g/ton)). In comparison with sheep, Angora goats appear more tolerant to high levels of monensin.

PR-4410

Computerized Decision Aids in Nutrition Management of Range Sheep

J.E. Huston

Summary

A software program was written for the Apple II computer to predict requirements for supplemental feed for breeding ewes on rangeland. Research data were summarized and formed the basis for estimating nutrients in forages; forage consumption; animal requirements; periods of deficiency; and a recommended feed type, feeding level, and feeding period. Responses by the user regarding rangeland type and plant composition, animal size and breeding date, and a listing of acceptable feed formulations and prices are used in formulating recommendations.

Introduction

This report describes a software package developed at the Texas A&M University Research and Extension Center at San Angelo for aiding in decisions regarding supplemental feed needs for breeding ewes in the Edwards Plateau region of Texas.

Components of the Program

The program, named "FEEDSTUFF, Version 1-S" runs on an Apple II computer with at least 48 K (kilobytes) of RAM (Random Access Memory) and a single 5-1/4 inch floppy disk drive (Apple II+, IIe or IIc). An attached printer will allow for a printed copy of recommendations but is not essential for the pro-

gram to run. Also, various data files are stored on the disk and supply the programs with essential information. The six components (programs) of FEEDSTUFF will be discussed separately.

Introduction. The user is introduced to FEEDSTUFF and given training on how to respond to questions, select alternatives and proceed to the next step.

User Input. The user is asked to supply the following:

- 1) Average ewe weight (actual or estimated).
- 2) Estimated average breeding date.
- 3) Description of range vegetation based on variety of plant types.
- 4) Preferred feed concentrate from a list of nine common feeds (or user can allow FEEDSTUFF to recommend a feed concentrate).
- 5) Feed prices (\$/ton).

Diet and Requirements. Computations are made on how much ewes consume throughout the year and the amounts of energy, protein, and phosphorus contained in these diets. These computations were based on data for forage composition (1), diet selection (4), and response to supplemental feeds (2). Nutrient requirements were adapted from tabular recommendations of the National Research Council (3).

Plots. Forage quality, ewe requirements, dietary intake, periods of excess and periods of deficiency are graphically illustrated for each of the three nutrients (energy, protein, phosphorus). A January through December plot of forage composition depicts the highs and lows in forage quality associated with season and typical rainfall pattern. The 12-month production cycle, beginning with the breeding date, shows how nutrient requirements compare with dietary intake of nutrients. These plots give the user a hint of depth and duration of deficiency periods and how breeding date can be an important determinant of supplemental feed needs.

Deficiencies. Computations are made to determine when the ewes go into negative balance, how long they are able to use stored nutrients without adverse effect, and the beginning and ending dates of deficiency periods. Only energy can be consumed in excess and stored efficiently for later use. The ewe's ability to store for later use is lower for phosphorus and much lower for protein. Sheep can endure rather extended periods of marginal to low energy nutrition provided these periods are preceded and followed by periods of excess. These beginning and ending dates, the amounts of stored nutrients, nutrient depletion rates, and extent of nutrient deficiencies are computed.

Feed Recommendations. A feeding rate and feeding period are recommended for the designated feed or the feed selected by FEEDSTUFF for least-cost to supply energy and protein requirements. In neither case is phosphorus considered. However, FEEDSTUFF computes whether phosphorus requirements are satisfied by the recommended feed concentrate and feeding level. If not, a phosphorus-containing mineral formula is recommended for free-choice feeding. Following the initial feed concentrate recom-

mendation, the user is given the option of trying another feed concentrate. Finally, the user is given the option to either start over with a new set of conditions or end the session.

This software package is one of a planned family of decision aids based on animal and plant data collected at the Texas A&M University Agricultural Research and Extension Center at San Angelo. Concurrently, Version 1-C and Version 1-G are being completed to apply to cows and goats, respectively. Immediate plans include a Version 2 of FEEDSTUFF which will add considerations of forage quantity, moisture conditions, animal species combinations, feed distribution costs, and marginal return to increased feeding rates below requirements.

Literature Cited

1. Huston, J.E., B.S. Rector, L.B. Merrill, and B.S. Engdahl. 1981. Nutritional value of range plants in the Edwards Plateau region of Texas. Tex. Agri. Expt. Sta. B-1357.
2. Huston, J.E. 1983. Production of fine-wool ewes on yearlong rangeland in West Texas. II. Effects of supplemental feed and breeding frequency on reproductive rate. J. Anim. Sci. 56:1277.
3. NRC. 1985. Nutrient Requirements of Sheep. Washington, D.C. National Academy Press.
4. Rector, B.S. 1983. Diet selection and voluntary forage intake by cattle, sheep, and goats grazing in different combinations. Ph.D. Dissertation. Texas A&M Univ. College Station, TX.

PR-4441

A Conceptual Overview of the TAMU Sheep Production Model

H. D. Blackburn and T. C. Cartwright

Summary

An overview of a computer model developed to simulate the biological response of sheep is presented. The model is capable of simulating any breed of sheep in different environments, which are specified by the forage available for consumption, with a wide array of management options. Results from the model are for many characters and include growth rates, weaning and yearling weights, ewe body weight fluctuations, reproductive performance, mortality, wool production, and the weight of lean and fat of lambs sold for slaughter. Use of the model allows researchers of any discipline an opportunity to examine more production alternatives than would be feasible with live animals. The model can also provide insight into key or critical areas where live animal research needs to be initiated.

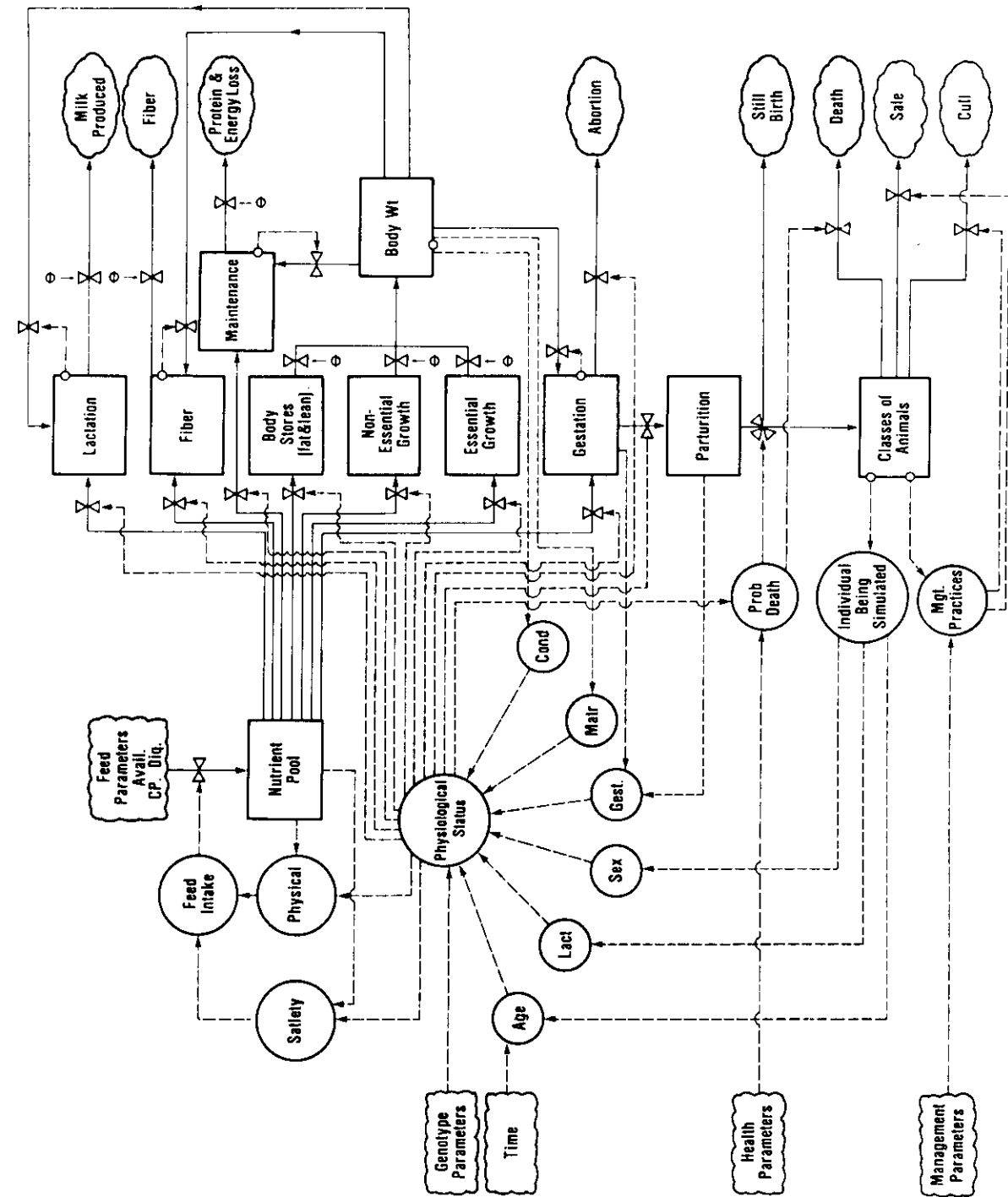

Figure 1. A conceptual overview of the sheep model.

Introduction

Sheep production in Texas and the United States utilizes a wide array of production resources and includes intensive, extensive and migratory production systems. Within each of these production systems there are numerous decisions and options to consider, the desired outcome of which is the maximization, within certain constraints, of sheep products (meat and wool). How are researchers, administrators, extension personnel, and producers to determine the effect of these options on the total production system where there are many interacting trade-offs? A methodology which can attempt to answer these questions is systems analysis.

Systems analysis is a method of organizing information about the individual biological components of the sheep (or flock of sheep) into a unified structure. Then systems analysis uses the structure or model to examine how the sheep will react in different production situations. Without such a model to interrelate the different biological components, it would be difficult to determine how factors affecting one part of the sheep or flock could affect another seemingly unrelated biological process within the sheep or flock.









The goal of systems analysis is to quantify and characterize the biological interactions which occur within the sheep, program these in mathematical terms into a computer model, and use the computer model to study the response of sheep to varying levels of management, nutrition and genetic potentials. This model enables researchers to examine how sheep respond to changing environmental conditions or how different breeds or types of sheep respond to the same environment where the environment consists of the physical and managerial conditions of the production system. The model is constructed in such a way that almost any production situation can be simulated, if the proper forage (diet), managerial, and breed parameters are specified. A major advantage of using systems analysis in sheep experimentation is the reduction in demand for labor, time, and financial resources.

Model Description

The computer program that has been developed integrates the different biological components (age, maturity, lactational status, etc.) of a sheep into a unit (or animal). A conceptual overview of the model can be seen in Figure 1. A description of the symbols used in Figure 1 is given in Table 1. Model inputs are aligned on the left side, and all model outputs are on the right side of the diagram (Figure 1). The flow of protein and energy can be followed from the nutrient pool to the various levels where nutrients are used. The flow of nutrients is determined by the physiological status of the animal being simulated. The physiological status is altered by the auxiliaries: age, lactation status, sex, gestation status, maturity, and body condition. The physiological status for any two animals will be different if they are of different ages, sexes, or have had different nutritional backgrounds so that body condition is different. These factors exert a force over the physiological status which in turn determines where nutrients flow and the amount of nutrients which are divided between the various requirements.

The model simulates every animal in the flock, one at a time, on a 15-day time step. That is, all biological and management changes are updated every 15th day. An example of the procedure the computer program goes through for a sheep is given in Figure 1. If we assume a mature sheep which is lactating and not pregnant, we can follow the activity of the model during one time step. First, the auxiliary physiological status will synthesize information about this ewe (e.g., body condition, age maturity, etc.) and determine the level of feed she can consume; the feed consumed (which may be less than desired if pasture conditions are poor) goes into the nutrient pool. From the nutrient pool, protein and energy from the consumed feed is divided between lactation, maintenance, body stores, and fiber. Other levels, such as gestation and growth have been "shut off" by the controlling auxiliary physiological status. If the ewe is not able to consume sufficient feed (due to limited quantities of feed or feed quality is limiting intake), she will

Table 1. A list of symbols used in the conceptual flowchart

Symbol	Description of symbols
	Input parameter; information supplied to the model.
	Output from the model. These are offtakes (kilograms of animals sold or milk used for human consumption) or losses from the system.
	Levels, which hold protein and energy in various forms; forage, lean weight, and fat weight.
	Auxiliary variables; controls which determine the rate of flow of protein and energy from one level to another.
	The path of protein and energy between levels.
	Information links between auxiliaries and valves and feedback from levels to auxiliaries.
	Valves controlling the rate of flow of materials.
	Constants which control the flow rate through the valves.

catabolize her body weight to provide protein, energy, or both to meet her maintenance and lactation requirements. If there is still a nutritional deficiency, production is decreased proportionally to represent the deficit.

A listing of the classes of animals which are simulated is given in Table 2. All simulated animals are classified according to biological and management criteria which are determined by the simulator. For example sheep can be divided into classes (e.g., breeding ewes and replacement ewes) on the basis of age only. The divisions by age will then be dependent upon the production system being simulated. By placing animals into the various classes listed, different management operations can be carried out on a particular class. For example, we may wish to simulate the effects of supplemental feeding of nursing lambs but not the remainder of the flock; the manner in which the classes are structured allows us to do this. A listing to further indicate information that is simulated and accounted for in each animal, within a class, is given in Table 3. The individual's record is divided into several categories: a) identification—each animal is assigned a number at birth and is placed in a class specifying management group, pasture, and supplementation (if any); b) phenotype—the simulated sheep's physical attributes are kept and updated with time; and c) the phenotype for females—keeps track of the ewe's reproductive performance, past and present, and the amount of milk she produces.

The user is required to provide the model with three types of data for simulations: a) genetic potentials of the sheep, b) feed resource specification, and c) management practices. The items are referred to as input parameters. The genetic potential parameters specified are mature weight, maturing rate, wool growth rate, potential peak milk production level, seasonality of breeding, and ovulation rate. The feed resource is specified on a 15-day (1 period) basis. Four items must be specified for each period: digestibility and crude protein of the forage diet, availability of forage (which contains the crude protein and digest-

Table 2. Animal classes which can be simulated in the sheep model

Animal classes
1. Sale ewe lambs
2. Sale ewes
3. Breeding ewes
4. Replacement ewe lambs
5. Nursing ewe lambs
6. Muttons
7. Wethers
8. Nursing wether lambs
9. Sale ram lambs
10. Breeding rams
11. Replacement rams
12. Nursing ram lambs
13. Female fetuses
14. Male fetuses

ibility of the diet) expressed in kg/head/day, and the amount of any supplement fed. The management practices currently being used in real life or those which are to be tested must also be specified. These include: breeding season, weaning policy, sales policy, flock health program, selection/culling practices, dairy practices, supplemental feeding, and time of shearing.

Before experimental simulations are performed, a baseline validation should be performed for the base production system simulated. A baseline validation compares how closely the model simulated the actual production of sheep observed in real life. To perform a validation the input parameters must be supplied to the model. Of course, animal performance data (growth rates, ewe body weights, milk production levels, reproductive rate, and mortality rates) must be available, at least in part, for comparison. These performance data should have been collected at the same time that forage parameters were collected so that it is possible to examine the animal's response to fluctuations in the forage resource. Upon successful completion of the validation, experimental simulations may begin.

The sheep model was constructed so that it can be used for several types of simulations. Its primary function is to simulate any type of sheep experiment

Table 3. Record of information stored and updated on every simulated animal

Animal record
A. Identification
1. ID number
2. Breed
3. Class
4. Management group
5. Pasture
6. Supplement
B. Phenotype (all animals)
1. Weight (W)
2. Structural size (WM)
3. Weight of lean (WL)
4. Empty body weight (EBW)
5. Fleece weight (FW)
6. Rumen fill (FILL)
7. Change in W
8. Change in WM
9. Change in WL
10. Change in EBW
11. Change in FILL
12. Change in FW
13. Dry matter intake
14. Metabolizable energy intake
15. Crude protein intake
C. Phenotype (females only)
1. Cycling/pregnancy status
2. Lactation/nursing status
3. Lactation capacity used last period
4. Periods since lambing/dystocia
5. Number of parturitions
6. Milk production
7. Fraction milk extracted (dairy use)

which evaluates animal performance in terms of body weight, wool production, reproductive performance, and production efficiency (output/input). Such use results in the reduction of the cost of research, time required to obtain results, and identification of key areas (production constraints) for live animal research. Model results quantify the animals' response to changes in the production system, increased feed resources, or production from different breeds of sheep.

The model can be used to develop production management strategies to improve productivity. For example, how the sheep respond to interventions, such as supplementation, breed alternatives, and health treatments can be tested and synthesized into production options which include one or more of the tested interventions. Further analyses can then be done to test the trade-offs between production packages. Model results provide estimates of dry matter consumed by the sheep flock. This information can be used to determine the portion of biomass utilized and

how this use relates to stocking rate. Because of the number of different options the sheep model can simulate, the output is very useful in economic analysis. It is capable of providing economists information on the amount of feed consumed and the offtake in terms of meat and wool. This information can be used in linear programs which evaluate entire farm enterprises.

In this paper the general structure of the sheep model has been described. From this description, it is evident that the model is very flexible in terms of the genetic, environmental, and management options which can be simulated. This flexibility increases the types of production environments in which the model can be used.

Acknowledgements

This research was carried out as part of the United States Agency for International Development Title XII Small Ruminant Collaborative Research Support Program under Grant No. AID/DSAN/XII-G-0049.